



NOTE: due to the fact that that the text of this file was generated automatically, there may be cases where the numbering of an AMC/GM does not fully correspond to that contained in the relevant "clean" file

~~European Aviation Safety Agency~~

COMMENT RESPONSE DOCUMENT (CRD)
TO NOTICE OF PROPOSED AMENDMENT
(NPA) 2011-20 (B.II)

~~RMT.0136 (ADR.001 (a)) & RMT.0137 (ADR.001 (b))~~

~~RMT.0140 (ADR.002 (a)) & RMT.0141 (ADR.002 (b))~~

~~RMT.0144 (ADR.003 (a)) & RMT.0145 (ADR.003 (b))~~

~~*'Authority, Organisation and Operations Requirements for*~~
~~**Aerodromes**~~~~*'*~~

(B.II) CRD to NPA 2011-20 (B.II) — Draft AMC/GM



~~AMC1 — Article 3 Oversight capabilities~~

~~CONFLICT OF INTEREST~~

~~The competent authority should ensure that the cases of conflict of interest which are related to family or financial interest are also addressed.~~

SUBPART A – GENERAL REQUIREMENTS (ADR.AR.A)

Terminology

'Guidance Material' (GM) means non-binding material developed by the Agency that helps to illustrate the meaning of a requirement or specification, and is used to support the interpretation of the Basic Regulation, its Implementing Rules, and AMC.

GM to Regulation XXX

GM1 Article 8 Safeguarding of aerodrome surroundings

Other surfaces associated with the aerodrome are surfaces that need to be established when operating in accordance with ICAO PANS-OPS Doc 8168, Volume II, or its equivalent in the national law, when applicable. The term 'surfaces' in this meaning is not used uniformly in different sources of information where also terms 'area' or 'zone' may be used.

AMC/GM to ANNEX I – Part Authority Requirements (Part-AR)

SUBPART A –GENERAL REQUIREMENTS (ADR.AR.A)

GM1-ADR.AR.A.010—(b) Oversight documentation

AVAILABILITY OF DOCUMENTATION TO THIRD PARTIES

The legislative acts, standards, rules, technical publications, and similar documents can be made available, in a timely manner, to the aerodrome operators and any other interested party in various ways and formats, such as via its website, the government's official gazette, or any other similar means.

The way for making such material available, including possible application of fees, ~~it~~ is for the ~~competent authority~~ Competent Authority to decide.

Making such documentation available is without prejudice to the application of rules regarding protection of intellectual property rights, or similar applicable legislation.

GM1-AMC1 ADR.AR.A.015—(d)(3) Means of compliance

GENERAL

The information to be provided to other Member States following approval of an alternative means of compliance should contain a reference to the Acceptable Means of Compliance (AMC) to which such means of compliance provides an alternative, as well as a reference to the corresponding Implementing Rule, indicating as applicable the subparagraph(s) covered by the alternative means of compliance.

GM1 ADR.AR.A.015 Means of compliance

GENERAL

Alternative means of compliance used by a ~~competent authority~~ Competent Authority or by organisations under its oversight may be used by other competent authorities or organisations only if processed again in accordance with ADR.AR.A.015 (d) and (e).

SUBPART A – GENERAL REQUIREMENTS (ADR.AR.A)

AMC1- ADR.AR.A.020 — Notification of cases of equivalent level of safety and special conditions

~~DOCUMENTATION TO BE PROVIDED~~

~~The competent authority should provide~~**25(b) Information to the Agency** ~~with a description of such equivalent level of safety or special conditions.~~

~~Such documentation may include but is not limited to:~~

- ~~— description of the situation;~~
- ~~— rationale;~~
- ~~— description and the technical and operational characteristics of the solution applied;~~
- ~~— safety assessments;~~
- ~~— mitigating measures applied, if applicable.~~

SAFETY SIGNIFICANT INFORMATION

(to be provided at a later stage)

AMC1- ADR.AR.A.030(d) — Immediate reaction to a safety problem

NOTIFICATION OF MEASURES

~~In case that~~When the ~~competent authority~~Competent Authority directs a measure to a provider of apron management services, ~~then~~ these measures should also be notified to the aerodrome operator.

GM1- ADR.AR.A.040 — (b) Safety Directives

FORWARDING OF SAFETY DIRECTIVES

~~Member States' competent authorities may issue safety directives (which may be called operational directives, or otherwise) during its oversight activities, such as an instruction to the aerodrome operator to abstain from a certain activity, or a positive action (e.g. cutting of trees which are found to penetrate the OLS, or the removal of certain object from the aerodrome etc.) needed to maintain the level of safety. Such safety directives are not meant to be forwarded to the Agency.~~

The safety directives that ~~need to~~should be forwarded to the Agency under ADR.AR.A.040 include, but are not limited, to, cases like the following ones, where the ~~competent authority~~Competent Authority has determined:

- (a) that it is necessary to include additional certification specifications in the certification asis~~basis~~ of an aerodrome;
- (b) that aerodrome equipment has presented unusual, or frequent, or otherwise unjustified malfunctions or failures;
- (c) that the certification specifications established by the Agency are such that under given conditions additional action is required to be undertaken in order to maintain the level of safety;

SUBPART A – GENERAL REQUIREMENTS (ADR.AR.A)

- (d) that there is immediate need to take certain action in order to respond to a safety recommendation or following an accident or serious incident; or
- (e) that this or a similar unsafe condition may be present at other aerodromes of the same Member State.

Member States' competent authorities may issue directives (which may be called operational directives, or otherwise) during its oversight activities, such as an instruction to the aerodrome operator to abstain from a certain activity, or a positive action (e.g. cutting of trees which are found to penetrate the OLS, or the removal of certain object from the aerodrome etc.) needed to maintain the level of safety. Such directives are not meant to be forwarded to the Agency.

SUBPART B – MANAGEMENT (ADR.AR.B)

AMC1-ADR.AR.B.005(a) – Management system

GENERAL

~~GENERAL~~

- (a) The following should be considered when deciding upon the required organisational structure:
- (1) the number of certificates and approvals to be issued;
 - (2) the number of declared organisations;
 - (3) the number and complexity of aerodromes, aerodrome operators, and providers of apron management services within that Member State;
 - (4) the possible allocation of tasks to third natural or legal persons of resources needed to fulfil the continuing oversight obligations;
 - (5) the level of civil aviation activity;
 - (6) the size of the Member State's aviation industry; and
 - (7) ~~it should also take into account~~ the potential growth of activities in the field of civil aviation.
- (b) The set-up of the organisational structure should ensure that carrying out the various tasks and obligations of the ~~competent authority~~ Competent Authority do not rely solely on individuals. That means that a continuous and undisturbed fulfilment of these tasks and obligations of the ~~competent authority~~ Competent Authority should also be guaranteed in case of illness, accident, or leave of individual employees.

GM1-ADR.AR.B.005(a) – Management system

GENERAL

GENERAL

- (a) The ~~competent authority~~ Competent Authority designated by each Member State should be organised in such a way that:
- (1) there is specific and effective management authority in the conduct of all relevant activities;
 - (2) the functions and processes described in the applicable requirements of Regulation (EC) No 216/2008 and its Implementing Rules, and AMCs, CSs, and GM may be properly implemented;
 - (3) the ~~competent authority's~~ Competent Authority's organisation and operating procedures for the implementation of the applicable requirements of the Regulation (EC) No 216/2008 and its Implementing Rules are properly documented and applied;
 - (4) all competent authority personnel involved in the related activities are provided with training where necessary;

SUBPART B – MANAGEMENT (ADR.AR.B)

- (5) specific and effective provision is made for the communication and interface as necessary with the Agency and the competent authorities of other Member States; and
- (6) all functions related to implementing the applicable requirements are adequately described.
- (b) A general policy, in respect of activities related to the applicable requirements of Regulation (EC) No 216/2008 and its Implementing Rules, including certification specifications, should be developed, promoted, and implemented by the manager at the highest appropriate level; for example the manager at the top of the functional area of the ~~competent authority~~ Competent Authority that is responsible for such activities.
- (c) Appropriate steps should be taken to ensure that the policy is known and understood by all personnel involved, and all necessary steps should be taken to implement and maintain the policy.
- (d) The general policy, whilst also satisfying additional national regulatory responsibilities, should in particular take into account:
 - (1) the provisions of Regulation (EC) No 216/2008;
 - (2) the provisions of the applicable Implementing Rules and their ~~acceptable means~~ Acceptable Means of compliance, ~~certification specifications~~ Certification Specifications, and ~~guidance material~~ Guidance Material;
 - (3) the needs of industry; and
 - (4) the needs of the Agency and of the ~~competent authority~~ Competent Authority.
- (e) The policy should define specific objectives for key elements of the organisation and processes for implementing related activities, including the corresponding control procedures and the measurement of the achieved standard.

AMC1-ADR.AR.B.005(a)(1) – Management system

DOCUMENTED POLICIES AND PROCEDURES

- (a) The various elements of the organisation involved with the activities related to the applicable requirements of Regulation (EC) No 216/2008 and its Implementing Rules should be documented in order to establish a reference source for the establishment and maintenance of this organisation.
- (b) The documented policies and procedures should be established in a way that facilitates their use. They should be clearly identified, kept up-to-date, and made readily available to all personnel involved in the relevant activities.
- (c) The documented policies and procedures should cover, as a minimum, the following aspects:
 - (1) policy and objectives;
 - (2) organisation structure;
 - (3) responsibilities and associated authority;
 - (4) processes and ~~procedures and processes~~;
 - (5) internal and external interfaces;
 - (6) internal control procedures;

SUBPART B – MANAGEMENT (ADR.AR.B)

- (7) training of personnel;
 - (8) cross references to associated documents; and
 - (9) assistance from other competent authorities or the Agency (where required).
- (d) Except for smaller competent authorities, it is likely that the information is held in more than one document, or series of documents, and suitable cross-referencing should be provided. For example, organisational structure and job descriptions are not usually in the same documentation as the policies and the detailed working procedures. In such cases, it is recommended that the documented procedures include an index of cross references to all such other related information, and the related documentation should be readily available when required.

GM1 ADR.AR.B.005(a)(1) Management system

DOCUMENTED POLICIES AND PROCEDURES

For the procedures meant here see also AMC1– ADR.AR.B.005(d).

AMC1 ADR.AR.B.005(a)(2) — Management system

SCOPE AND DURATION OF INITIAL TRAINING OF AERODROME INSPECTORS

Initial training should encompass:

- (a) ———initial theoretical training;
- (b) ———practical training; and
- (c) ———on-the-job training.

(a) Initial theoretical training

The scope of the initial theoretical training is to familiarise the trainee aerodrome inspectors with the finding categorisation, reporting, follow-up procedures, and enforcement. The primary scope of the theoretical training is not the transfer of technical knowledge, as the trainees should possess such knowledge, either from previous work experience or through specialised training, prior to attending the theoretical course (for areas of training see ~~AMC4 ADR.AR.B.005 (a) (2)~~ AMC3 ADR.AR.B.005(a)(2). Amongst others, the theoretical training should cover theory of audits and inspections, as well as quality/safety assurance.

(b) Practical training

The scope of practical training is to instruct on audit/inspection techniques and specific areas of attention without interference with the operation of the aerodrome activities.

(c) The Competent Authority should ensure that trainees have successfully completed the initial theoretical and practical training above by passing a relevant assessment.

~~(c)~~(d) On-the-job training

The objective of the on-the-job training is to familiarise the trainees with the particularities of performing an aerodrome audit/inspection in a real, operational environment. ~~The competent authority should ensure that on-the-job training is~~

SUBPART B – MANAGEMENT (ADR.AR.B)

~~undertaken only by trainees that have successfully completed the initial theoretical and practical training above by passing a relevant evaluation.~~

(1) Duration and conduct of the on-~~the-job~~ training

~~—The duration of the on-the-job training should be customised to the particular training needs of every trainee, and should start as soon as possible after the completion of the practical training~~ and cover, as much as possible, the audit/inspection items which the inspector will be privileged to inspect. The on-the-job training should include at least ~~two~~four aerodrome audits/ inspections.

(2) Elements to be covered during the on-the-job training

~~—On the job training should address the following elements:~~

(i) Preparation of an audit/inspection:

- (A) sources of information for preparation of audit/inspection;
- (B) areas of concern and/or open findings;
- (C) selection of aerodrome operator(s) to be audited/inspected; and
- (D) task allocation among members of the audit/inspection team.

(ii) Administrative issues of the inspection:

- (A) aerodrome inspector's credentials, rights, and obligations;
- (B) aerodrome access procedures;
- (C) safety and security airside procedures; and
- (D) aerodrome inspector's toolkit (fluorescent vest, checklists, clinometer, distance measurement devices, digital camera, GPS, etc.).

(iii) Audit/Inspection:

- (A) introduction — opening meeting;
- (B) on-site activities (audit/inspection according to the area of expertise of the trainee);
- (C) findings (identification, categorisation, evidencing, reporting); and
- (D) corrective actions — enforcement.

(iv) Closing meeting — debriefing on the audit/inspection conclusions

(v) Preparation, completion, and delivery of the audit/inspection report

(vi) Human factors elements:

- (A) cultural aspects;
- (B) resolution of disagreements and/or conflicts; and
- (C) auditee stress.

(vii) Team leading if required

(viii) Post-audit/inspection procedures, such as monitoring the status of open audit findings, follow-up audits/inspections, and closing the findings after appropriate action has been taken by the aerodrome operator.

(3) Assessment of trainee aerodrome inspectors:

SUBPART B – MANAGEMENT (ADR.AR.B)

The assessment of the trainee should be done by the aerodrome inspector providing the training. A trainee should be considered to have successfully completed the on-the-job training only after demonstrating to the aerodrome inspector providing the training that he/she possesses the professional competence, knowledge, judgement, and ability to perform aerodrome inspections in an operational environment, in accordance with the applicable requirements.

~~(d)~~(e) Aerodrome inspectors ~~providing~~appointed to provide training and assessing trainees

The aerodrome inspectors providing the training, and assessing trainee aerodrome inspectors, should be appointed by the ~~competent authority~~Competent Authority and should meet the qualification criteria established by that ~~competent authority,~~whichCompetent Authority. ~~These criteria should contain at least the following requirements:~~

- ~~(1) require that~~ the appointee has been a qualified aerodrome inspector ~~over the (see GM7 ADR.AR.B.005(a)(2), for the last~~ three years prior to his/her appointment;
- ~~(2) the appointee has performed the required number of inspections during the last thirty-six month prior to his appointment, in accordance with AMC4 ADR.AR.B.005.~~

Additional factors to be considered when nominating aerodrome inspectors to provide training, and assess trainee aerodrome inspectors include: knowledge of training techniques, professionalism, maturity, judgment, integrity, safety awareness, communication skills, and personal standards of performance.

AMC2-ADR.AR.B.005(a)(2) – Management system

QUALIFICATION OF AERODROME INSPECTORS AFTER SUCCESSFUL COMPLETION OF TRAINING

- (a) Upon the successful completion of the initial training (initial theoretical training, practical training, and on-the-job training) the ~~competent authority~~Competent Authority should issue a formal qualification statement for each qualified aerodrome inspector listing ~~itstheir~~ privileges. ~~The aerodrome inspectors~~Credentials should also be issued ~~credentials for the aerodrome inspectors~~, to facilitate their work.
- (b) The background knowledge and/or working experience of the aerodrome ~~inspector~~inspectors determines ~~itstheir~~ privileges (the scope of ~~his/her~~their inspection; what ~~he/she is~~they are entitled to inspect). The ~~competent authority~~Competent Authority should determine what the inspector is entitled to inspect taking into account the following considerations:
 - (1) background knowledge; and
 - (2) working experience.
- (c) The inspecting authority should put in place a system that will ensure that their aerodrome inspectors meet at all times the qualification criteria with regard to the eligibility, training, and recent experience.

AMC3-ADR.AR.B.005(a)(2) — Management system~~RECENT EXPERIENCE REQUIREMENTS FOR AERODROME INSPECTORS~~

- ~~(a) An aerodrome inspector will remain qualified if he/she performs a minimum number of two aerodrome audits/inspections during the previous 12 months. In case the minimum number of audits/inspections may not be achieved due to the number of aerodromes in a Member State, audits/inspections conducted on other aerodromes which are open to public use and which however do not fall within the scope of Regulation (EC) No 216/2008, may also be taken into account.~~
- ~~(b) If an aerodrome inspector loses his/her qualification as a result of not reaching the minimum number of inspections mentioned in paragraph (a), he/she may be re-qualified by the competent authority by performing the number of the missed audits/inspections under the supervision of a qualified aerodrome inspector. The missed audits/inspections should take place within a maximum period of 3 months following the end of the period within which he/she should have reached the minimum number of audits/inspections.~~
- ~~(c) If an aerodrome inspector loses his/her qualification because he/she has not been engaged in performing audits/inspections for a period larger than that established in paragraph 2 but less than 24 months, he/she should be re-qualified by the competent authority only after successfully completing on-the-job training and any recurrent training required.~~
- ~~(d) If an aerodrome inspector loses his/her qualification because he/she has not been engaged in performing audits/inspections for more than 24 months, he/she should be fully re-qualified by the competent authority only after successfully completing initial theoretical, practical and on-the-job training.~~

AMC4-ADR.AR.B.005(a)(2) — Management System

TRAINING PROGRAMME AND RECURRENT TRAINING

- (a) The ~~competent authority~~ Competent Authority should establish a training programme for its personnel, including its aerodrome inspectors, and a plan for its implementation. The training programme should include, as appropriate to the role, current knowledge, experience and skills, of the personnel, at least the following:
- (1) aviation legislation, organisation, and structure;
 - (2) the Chicago Convention, relevant ICAO Annexes and documents, the applicable requirements of Regulation (EC) No 216/2008, its Implementing Rules and related ~~acceptable — means~~ Acceptable — Means of ~~compliance, — certification specifications~~ Compliance, — Certification Specifications and ~~guidance material~~ Guidance Material, as well as assessment methodology of the alternative means of compliance, and the applicable national legislation;
 - (3) the applicable requirements and procedures;
 - (4) areas of particular interest that include, but are not limited to:
 - (i) management systems, including safety management systems, safety assurance principles, and quality and security management systems as applied to aeronautical data and aeronautical information;
 - (ii) acceptability and auditing of safety managements systems;
 - (iii) change management;

SUBPART B – MANAGEMENT (ADR.AR.B)

- (iv) aeronautical studies, safety assessments, and reporting techniques;
 - (v) human factors principles;
 - (vi) aerodrome design;
 - (vii) signs, markings, and lighting;
 - (viii) aerodrome maintenance;
 - (ix) aerodrome operations, including:
 - (A) aerodrome safeguarding, including obstacle assessment;
 - (B) rescue and ~~fire-fighting~~ firefighting;
 - (C) emergency planning;
 - (D) disabled aircraft removal;
 - (E) low visibility operations;
 - (F) adverse weather operations;
 - (G) wildlife management;
 - (H) apron management and apron safety management;
 - (I) handling of ~~hazardous materials; dangerous goods; and~~ hazardous materials; dangerous goods; and
 - (J) fuel, facilities, storage and handling;
 - (x) evaluation, approval, and review of aerodrome manuals;
 - (xi) other suitable technical training appropriate to the role and tasks of the personnel, ~~in particular for those areas requiring approvals;~~ and
(xii) enforcement measures.
- (5) The training programme and plan should be updated, as needed, to reflect, at least, changes in aviation legislation, and industry. The training programme should also cover the specific needs of the personnel and the ~~competent authority~~ Competent Authority.
- (6) The ~~competent authority~~ Competent Authority should ensure that its personnel, including its aerodrome inspectors, undergo recurrent training at regular intervals defined by the ~~competent authority~~ Competent Authority or whenever deemed necessary, in order to be kept ~~up-to-date~~.

GM1-ADR.AR.B.005(a)(2) – Management system

AERODROME INSPECTORS – DUTIES

- (a) An aerodrome inspector is considered to be any person to whom the ~~competent authority~~ Competent Authority has formally assigned tasks related to the safety oversight of aerodromes.
- (b) Apart from the aerodrome oversight tasks, an aerodrome inspector may also undertake other tasks that the ~~competent authority~~ Competent Authority finds necessary.

GM2-ADR.AR.B.005-AR-200(a)(2) – Management system

AERODROME INSPECTORS – QUALIFICATION

To require a pilot licence as a prerequisite for aerodrome inspectors would be advantageous.

GM3 ADR.AR.B.005(a)(2) Management System

QUALIFICATION OF PERSONNEL

The term qualification 'qualified' denotes fitness for the purpose. This may be achieved through fulfilment of the necessary conditions, such as completion of required training, or acquisition of a diploma or degree-

Qualification could, or through the gaining of suitable experience. It also be interpreted to mean includes the ability, capacity, knowledge, or skill that matches or suits an occasion, or makes someone eligible for a duty, office, position, privilege, or status. Qualification does not necessarily imply competence.

Certain posts may by nature be associated with the possession of certain qualifications in a specific field (e.g. civil rescue and firefighting, civil, mechanical, or electrical engineering, wildlife biology etc.). In such cases, the person occupying such a post is expected to possess the necessary qualifications at a level that is in accordance with the applicable national or community European Union legislation.

GM3-GM4 ADR.AR.B.005(a)(2) – Management system

QUALIFICATION AND TRAINING – GENERAL

(a) To ensure personnel remain competent, arrangements should be made for initial and recurrent training as required.

(b) With regard to sequence of particular components of initial training, the Competent Authority should ensure that on-the-job training is undertaken only by trainees that have successfully completed the initial theoretical and practical training.

~~(b)~~(c) The basic capability of the competent authority Competent Authority's personnel is a matter of recruitment, and normal management functions in selection of personnel for particular duties. Moreover, the competent authority Competent Authority should provide training in the basic skills, as required for those duties. However, to avoid differences in understanding and interpretation, it is considered important that all personnel be provided with further training specifically related to the applicable requirements of Regulation (EC) No 216/2008, its Implementing Rules and related AMCs, CS, AMC, CS and GM, as well as related to the assessment of alternative means of compliance.

~~(c)~~(d) The competent authority Competent Authority may provide training through its own training organisation with qualified trainers or through another qualified training source (e.g. training provided by other competent authorities or the Agency).

~~(d)~~(e) When training is not provided through an internal training organisation, adequately experienced and qualified persons may act as trainers, provided their training skills have been assessed. If required, an individual training plan should be established covering specific training skills. Records should be kept of such training and of the assessment, as appropriate.

GM4-GM5 ADR.AR.B.005(a)(2) – Management System

SUFFICIENT PERSONNEL

SUBPART B – MANAGEMENT (ADR.AR.B)

- (a) This ~~guidance material~~ **Guidance Material** for the determination of the required personnel is limited to the performance of certification and oversight tasks, excluding personnel required to perform tasks subject to any national regulatory requirements.
- (b) The elements to be considered when determining required personnel and planning their availability_x may be divided into quantitative and qualitative elements:
- (1) Quantitative elements:
- (i) the number of initial certificates to be issued;
 - (ii) the number of aerodromes and aerodrome operators certified by the ~~competent authority; and~~ **Competent Authority;**
 - ~~(iii)~~ **(iii)** the number of providers of apron management services having declared their activity to the ~~competent authority~~ **Competent Authority;**
 - ~~(iv)~~ **(iv)** the number of planned aerodrome audits and inspections; and
 - ~~(iii)~~ **(v)** the number of expected changes to the aerodrome infrastructure.
- (2) Qualitative elements:
- (i) the size, nature_x and complexity of activities of aerodromes and aerodrome operators, as well as providers of apron management services:
 - (A) privileges of the aerodrome operator;
 - (B) type of approval, scope of approval;
 - (C) possible certification to industry standards;
 - (D) types of aerodromes operated;
 - (E) number of personnel; and
 - (F) organisational structure, existence of subsidiaries.
 - (ii) results of past oversight activities, including audits, inspections_x and reviews, in terms of risks and regulatory compliance:
 - (A) number and level of findings; and
 - (B) implementation of corrective actions.
 - (iii) the size of the Member State's aviation industry_x and the potential growth of activities in the field of civil aviation, which may be an indication of the number of new applications and changes to existing certificates to be expected.
- (c) Based on existing data from previous oversight planning cycles_x and taking into account the situation within the Member State's aviation industry, the ~~competent authority~~ **Competent Authority** may estimate:
- (1) the standard working time required for processing applications for new certificates;
 - (2) the standard working time required for processing declarations;
 - (3) the number of new declarations_x or changed declarations;
 - (4) the number of new certificates to be issued for each planning period; and
 - (5) the number of changes to existing certificates to be processed for each planning period.

- (d) In line with the ~~competent authority's~~Competent Authority's oversight policy, the following planning data should be determined specifically for each aerodrome and aerodrome operator, as well as for declared providers of apron management services:
- (1) standard number of audits/inspections to be performed per oversight planning cycle;
 - (2) standard duration of each audit/inspection;
 - (3) standard working time for audit/inspection preparation, on-site audit/inspection, reporting and follow-up, per aerodrome inspector; and
 - (4) minimum number and required qualification of aerodrome inspectors for each audit/inspection.
- (e) Standard working time could be expressed either in working hours per aerodrome inspector, or in working days per aerodrome inspector. All planning calculations should be based on the same unit (hours or working days).
- (f) It is recommended to use a ~~spreadsheets~~spread sheet application to process data defined under (c) and (d) above, to assist in determining the total number of working hours/days per oversight planning cycle required for certification, oversight and enforcement activities. This application could also serve as a basis for implementing a system for planning the availability of personnel.
- (g) For each aerodrome, aerodrome operator and provider of apron management services, the number of working hours/days per planning period for each qualified aerodrome inspector that may be allocated for certification, oversight and enforcement activities should be determined, taking into account:
- (1) purely administrative tasks not directly related to oversight and certification;
 - (2) training;
 - (3) participation in other projects;
 - (4) planned absence; and
 - (5) the need to include a reserve for unplanned tasks or unforeseeable events.
- (h) The determination of working time available for certification, oversight and enforcement activities should also consider the possible use of ~~third natural or legal persons~~qualified entities.
- (i) Based on the elements listed above, the ~~competent authority~~Competent Authority should be able to:
- (1) monitor dates when audits and inspections are due and when they have been carried out;
 - (2) implement a system to plan the availability of its personnel; and
 - (3) identify possible gaps between the number and qualification of its personnel and the required volume of certification and oversight.
- Care should be taken to keep planning data up-to-date, in line with changes in the underlying planning assumptions, with particular focus on risk-based oversight principles.

GM5-GM6 ADR.AR.B.005(a)(2) – Management System

SUBPART B – MANAGEMENT (ADR.AR.B)

TRAINING PROGRAMME AND RECURRENT TRAINING

When preparing the training programme, the ~~competent authority~~ Competent Authority should determine the areas for which the training may include realistic training elements.

As an example, the RFFS training could include parts of, or be the same with that of an aerodrome operator's RFFS personnel. If an aerodrome operator provides such training, care should be taken to avoid any possible conflict of interest.

GM7 ADR.AR.B.005(a)(2) Management systemRECENT EXPERIENCE REQUIREMENTS FOR AERODROME INSPECTORS

- (a) An aerodrome inspector will remain qualified if he/she performs a minimum number of two aerodrome audits/inspections during the previous 12 months. In case the minimum number of audits/inspections are not achieved due to the number of aerodromes in a Member State, audits/inspections conducted on other aerodromes which are open to public use, and which, however, do not fall within the scope of Regulation (EC) No 216/2008, may also be taken into account.
- (b) If an aerodrome inspector loses his/her qualification as a result of not reaching the minimum number of inspections mentioned in paragraph (a), he/she may be re-qualified by the Competent Authority by performing the number of the missed audits/inspections under the supervision of a qualified aerodrome inspector. The missed audits/inspections should take place within a maximum period of three months following the end of the period within which he/she should have reached the minimum number of audits/inspections.
- (c) If an aerodrome inspector loses his/her qualification because he/she has not been engaged in performing audits/inspections for a period longer than that established in paragraph (a) but less than 24 months, he/she should be re-qualified by the Competent Authority only after successfully completing the on-the-job-training, and any recurrent training required.
- (d) If an aerodrome inspector loses his/her qualification because he/she has not been engaged in performing audits/inspections for more than 24 months, he/she should be fully re-qualified by the Competent Authority only after successfully completing initial theoretical, practical, and on-the-job training.

GM1-ADR.AR.B.005(a)(3) — Management system

FACILITIES AND OFFICE ACCOMODATION

Facilities and office accommodation include but ~~is~~ are not limited to:

- (a) adequate offices;
- (b) a technical library available for the competent authority personnel, or another method to ensure receipt, control, and distribution of necessary technical documentation;
- ~~(b)~~(c) office equipment, including computers and communication means;
- ~~(c)~~(d) transportation means;
- ~~(d)~~(e) personnel protective equipment; and

~~(e)~~(f) equipment necessary for auditing/inspecting the aerodrome and its facilities, such as cameras, clinometers, distance measurement devices, GPS etc.

AMC1- ADR.AR.B.005(a)(4) Management system

COMPLIANCE MONITORING MECHANISM

The mechanism to monitor compliance of the management system with the relevant requirements, and the adequacy of the procedures should:

- (a) include a feedback system of audit findings to ensure implementation of corrective actions as necessary; and
- (b) be the responsibility of a person, or group of persons who should be responsible to the senior management of the Competent Authority and who act independently of other managers within the organisation, and with direct access to the senior management of the Competent Authority and to appropriate management for safety matters.

AMC1 ADR.AR.B.005(c) – Management SystemCOORDINATION WITH OTHER ~~COMPETENT~~ AUTHORITIES OF THE MEMBER STATE

The ~~competent authority~~ Competent Authority should establish coordination arrangements with other ~~competent~~ authorities of the Member State. Such coordination arrangements should, in particular, include the following ~~competent~~ authorities:

- (a) security agencies, in order to ensure:
 - (1) international civil aviation security measures are integrated into the design and construction of aerodromes, and their facilities; and
 - (2) the optimisation of civil aviation security measures.
- (b) environmental protection authorities, for the management of conflicts between safety and environmental requirements;
- (c) local planning and land use authorities.

AMC1- ADR.AR.B.005(d) – Management system

PROCEDURES AVAILABLE TO THE AGENCY

- (a) Copies of the procedures in the ~~competent authority's~~ Competent Authority's management system should be made available to the Agency for the purpose of standardisation. These should include any amendments to the procedures. The procedures should provide, at least, the following information:
 - (1) ~~Regarding~~ regarding continuing oversight functions undertaken by the ~~competent authority~~ Competent Authority, the ~~competent authority's~~ Competent Authority's organisational structure with description of the main processes. This information should demonstrate the allocation of responsibilities within the ~~competent authority~~ Competent Authority, and that the ~~competent authority~~ Competent Authority is capable of carrying out the full range of tasks regarding the size and complexity of the Member State's aerodrome industry. It should, also, consider overall proficiency and authorisation scope of ~~competent authority~~ Competent Authority personnel;
 - (2) changes which significantly affect the ~~competent authority's~~ Competent Authority's oversight capabilities;
 - (3) for personnel involved in oversight activities, the minimum professional qualification requirements and experience, and principles guiding appointment (e.g. assessment);
 - (4) how the following are carried out: assessing applications and evaluating compliance, issuance of certificates, performance of continuing oversight, follow-up of findings, enforcement measures, and resolution of safety concerns;
 - (5) principles of managing exemptions, derogations, cases of equivalent level of safety, and special conditions;
 - (6) systems used to disseminate applicable safety information for timely reaction to a safety problem;
 - (7) criteria for planning continuing oversight (oversight programme), including adequate management of interfaces when conducting continuing oversight (aerodrome operations and ATS operations for example); and

SUBPART B – MANAGEMENT (ADR.AR.B)

- (8) outline of the initial training of newly recruited oversight personnel (taking future activities into account), and the basic framework for continuation training of oversight personnel.
- (b) The requirements of particular domains defined within the copy of the procedures of the ~~competent authority's~~ Competent Authority's management system (and amendments) should be considered.
- (c) As part of the continuous monitoring of a ~~competent authority~~ Competent Authority, the Agency may request details of the working methods used, in addition to the copy of the procedures of the ~~competent authority's~~ Competent Authority's management system (and amendments). These additional details are the procedures and related guidance material Guidance Material describing working methods for ~~competent authority~~ Competent Authority personnel conducting oversight.
- (d) Information related to the ~~competent authority's~~ Competent Authority's management system may be submitted in electronic format.

~~AMC1-GM2~~ ADR.AR.B.010010(a)(1) – Allocation of tasks to qualified entities
~~INDEPENDENCE OF PERSONS TO WHOM TASKS ARE ALLOCATED~~

~~A natural person or the management and the personnel of a legal person, to whom the~~
CERTIFICATION TASKS

~~The tasks that may be performed by a qualified entity on behalf of the~~ competent authority ~~intends to allocate tasks include those~~ related to the initial certification ~~or, and~~ continuing oversight of aerodromes, their operators, or providers, or apron management services ~~should not be involved directly or indirectly as defined in any kind this Regulation, with the exclusion of activity related to planning, design, maintenance, service provision, or any similar activity related to aerodromes, aerodrome operation or aerodrome management~~ the issuance of certificates or approvals.

~~AMC2-ADR.AR.B.010~~(a)(1) – Allocation of tasks to qualified entities

~~QUALIFICATIONS OF PERSONNEL~~

- (a) A ~~legal person~~ qualified entity, to which tasks related to the initial certification or continuing oversight tasks are to be allocated, should have an adequate number of qualified technical personnel to conduct aerodrome inspections and audits, and to perform any other task needed during the certification and oversight process, as required by the ~~competent authority~~ Competent Authority.
- (b) The ~~natural person or the~~ personnel of a ~~legal person~~ qualified entity, to whom such tasks are allocated, should meet the qualification criteria applicable for competent authorities' aerodrome inspectors prescribed in ~~AMC1-ADR.AR.B.005(a)(2), AMC2-ADR.AR.B.005(a)(2), and AMC3-ADR.AR.B.005(a)(2) and AMC4-ADR.AR.B.005(a)(2)-.)).~~ (see also GM7

~~GM1-ADR.AR.B.020-010~~ Allocation of tasks to qualified entities

~~CERTIFICATION TASKS~~

SUBPART B – MANAGEMENT (ADR.AR.B)

The tasks that may be performed by ~~a natural or legal person~~ qualified entities on behalf of the ~~competent authority~~ Competent Authority may include any tasks related to the initial certification and continuing oversight of aerodromes and aerodrome operators, as well as declared providers of apron management services, with the exclusion of the ~~issue~~ issuance of certificates or approvals.

AMC1-ADR.AR.B.020(a) – Record-keeping

GENERAL

- (a) The record-keeping system should ensure that all records are accessible whenever needed within a reasonable time. These records should be organised in a consistent way that ensures traceability and retrievability throughout the ~~competent authority~~ (chronological, alphabetical order, for example) – required retention period.
- (b) Records should be kept in paper form, or in electronic format, or a combination of both media. Records stored on microfilm or optical disc form are also acceptable. The records should remain legible and accessible throughout the required retention period. The retention period starts when the record has been created or last amended.
- (c) Computer systems should have, at least, one backup system which should be updated within 24 hours of any new entry. Computer systems should include safeguards against unauthorised alteration of data.
- (d) All computer hardware used to ensure data backup should be stored in a different location from that containing the working data, and in an environment that ensures they remain in good condition. When hardware or software changes take place, special care should be taken that all necessary data continue to be accessible, at least, through the full period specified in ADR.AR.B.020(c) and (d).

AMC1-ADR.AR.B.020(a)(1);(a)(2);(a)(3) – Record-keeping

COMPETENT AUTHORITY MANAGEMENT SYSTEM

Records related to the ~~competent authority's~~ Competent Authority's management system should include, as a minimum, and as applicable:

- (a) the documented policies and procedures;
- (b) the personnel files of ~~competent authority~~ Competent Authority personnel, with supporting documents related to their training and qualifications;
- (c) the results of the ~~competent authority's~~ Competent Authority's internal compliance monitoring and risk assessment, including audit findings and corrective actions; and
- (d) the contract(s) established with ~~natural and legal persons~~ qualified entities to whom tasks have been allocated regarding certification or oversight tasks on behalf of the ~~competent authority~~ Competent Authority.

AMC1-ADR.AR.B.020(d) Record keeping

DURATION OF RETENTION PERIOD OF RECORDS

Records related to the training and qualification of the personnel of the Competent Authority should be kept until the end of their employment.

AMC1 ADR.AR.B.020(a)(4);(a)(5) – Record-keeping**AERODROMES – AERODROME OPERATORS – APRON MANAGEMENT SERVICE PROVIDERS**

Records related to a certified aerodrome and its aerodrome operator, or the provider of apron management services having declared its activity to the ~~competent authority~~ Competent Authority should include, as appropriate to the type of organisation:

- (a) the application for a certificate, approval, or declaration;
- ~~(b)~~ (1) the documentation based upon which-:
 - (1) the certificate or an approval has been granted with amendments; and
 - ~~(1)~~(2) the declaration has been registered;
- ~~(b)~~(c) the documentation related to notifications of changes by the applicant and their assessment;
- ~~(e)~~(d) the certificate or approval issued, including any changes;
- ~~(d)~~(e) a copy of the continuing oversight programme listing the dates when audits are due and when such audits were carried out;
- ~~(e)~~(f) continuing oversight records, including all audit and inspection records;
- ~~(f)~~(g) copies of all relevant correspondence;
- ~~(g)~~(h) details of any exemption or derogation, and enforcement actions;
- ~~(h)~~(i) any report from other competent authorities relating to the oversight of the aerodrome, the aerodrome operator, and the provider of apron management services, if applicable; and
- ~~(i)~~(j) a copy of any other document approved by the ~~competent authority~~ Competent Authority.

AMC1-ADR.AR.B.020(c)(1) – Record-keeping**AERODROMES – AERODROME OPERATORS – PROVIDERS OF APRON MANAGEMENT SERVICES**

- (a) Records which are considered to be related to the certification of an aerodrome, and to be maintained for the lifespan of the certificate include, but are not limited to, the following:
 - (1) applications submitted;
 - (2) notifications of the ~~certification specifications~~ Certification Specifications for an initial certification and any changes thereof, including:
 - (i) any provisions for which an equivalent level of safety has been accepted; and
 - (ii) any special conditions.
 - (3) documentation related to alternative means of compliance used;
 - (4) documentation related to Deviation Acceptance and Action Documents(DAAD) if relevant;
 - ~~(4)~~(5) documentation related to exemptions or derogations granted;
 - ~~(5)~~(6) aeronautical studies and safety assessments;

SUBPART B – MANAGEMENT (ADR.AR.B)

~~(6)~~(7) designs of the aerodrome;

~~(7)~~(8) declarations made by the applicant;

~~(8)~~(9) current version of an aerodrome manual, and evidence of its evaluation; and

~~(9)~~(10) approvals granted.

- (b) Records for aerodrome equipment, or parts of the aerodrome infrastructure which have been removed from the aerodrome need not be maintained.
- (c) For providers of apron management services, records include, but may not be limited to, the declarations, and the relevant documentation submitted by the providers.

~~AMC1-~~

SUBPART B – MANAGEMENT (ADR.AR.B)

~~GM1~~ ADR.AR.B.020(d) – Record-keeping

~~AERODROMES – AERODROME OPERATORS – PROVIDERS OF APRON MANAGEMENT SERVICES~~

~~The competent authority should determine the retention period for those records that need to be maintained for a period of at least 5 years, taking into account:~~

- ~~(a) the need to have access to data (e.g. occurrence reports etc), that would allow it to identify trends, extract conclusions and plan its oversight activities; and~~
- ~~(b) the nature of the regulated area and the technical lifespan of a system.~~

~~GM1~~ ADR.AR.B.020 – Record-keeping

GENERAL

Records are required to document results achieved, or to provide evidence of activities performed. Records become factual when recorded. Therefore, they are not subject to version control. Even when a new record is produced covering the same issue, the previous record remains valid.

~~GM1~~ ADR.AR.B.020(a) – Record-keeping

MICROFILM AND OPTICAL STORAGE

Microfilming or optical storage of records may be carried out at any time. The records should be as legible as the original record, and remain so for the required retention period.

~~GM2~~ ADR.AR.B.020(a) – Record-keeping

AERODROMES – AERODROME OPERATORS – DOCUMENTATION

Documentation to be kept as records in support of the certificate or approval ~~include~~ includes the management system documentation, including any technical manuals, such as the aerodrome manual, that have been submitted with the initial application, and any amendments to these documents.

SUBPART C – OVERSIGHT, CERTIFICATION AND ENFORCEMENT (ADR.AR.C)**AMC1-ADR.AR.C.005 – Oversight**

GENERAL

- (a) The ~~competent authority~~ Competent Authority should assess the aerodrome operator, and monitor its continued competence to conduct safe operations in compliance with the applicable requirements and the certification basis. Similarly, the ~~competent authority~~ Competent Authority should monitor the continued competence of providers of apron management services. The ~~competent authority~~ Competent Authority should ensure that accountability for assessing and monitoring aerodrome operators, as well as providers apron management services, is clearly defined. This accountability may be delegated or shared, in whole or in part.
- (b) It is essential that the ~~competent authority~~ Competent Authority has the full capability to adequately assess the continued competence of an aerodrome operator, or a provider of apron management services by ensuring that the whole range of activities is assessed by appropriately qualified personnel.

GM1-ADR.AR.C.005 – Oversight

GENERAL

- (a) Responsibility for the safe operation of an aerodrome lies with the aerodrome operator. Under these provisions, a positive move is made towards devolving upon the aerodrome operator a share of the responsibility for monitoring the safety of operations. The objective cannot be attained unless aerodrome operators are prepared to accept the implications of this policy, including that of committing the necessary resources to its implementation. Crucial to success of the policy is the content of Part-ADR.OR which requires the establishment of a management system by the aerodrome operator.
- (b) The ~~competent authority~~ Competent Authority should continue to assess the aerodrome operator's compliance with the applicable requirements, including the effectiveness of its management system. If the management system is judged to have failed in its effectiveness, then this in itself is a breach of the requirements which may, among others, call into question the validity of the certificate.
- (c) The accountable manager is accountable to the ~~competent authority~~ Competent Authority as well as to those who may appoint him/her. It follows that the ~~competent authority~~ Competent Authority cannot accept a situation in which the accountable manager is denied sufficient funds, manpower, or influence to rectify deficiencies identified by the management system.

AMC1-ADR.AR.C.010(e) – Oversight programme~~OVERSIGHT PLANNING CYCLE~~

- ~~(a) The oversight planning cycle is determined by the date of issue of the certificate.~~
- ~~(b) The oversight planning cycle should be 24 months. It may be reduced if there is evidence that the safety performance of the aerodrome operator has decreased.~~

AMC/GM to Annex I – Part-AR

SUBPART C – OVERSIGHT, CERTIFICATION AND ENFORCEMENT (ADR.AR.C)

~~Moreover, the oversight planning cycle may be extended to a maximum of 36 months if the competent authority has established that, during the previous 24 months:~~

- ~~(1) the aerodrome operator has demonstrated an effective identification of aviation safety hazards and management of associated risks;~~
- ~~(2) the aerodrome operator has continuously demonstrated under ADR.OR.B.040 that it has full control over all changes;~~
- ~~(3) no category 1 findings have been issued; and~~
- ~~(4) all corrective actions have been implemented within the time period accepted or extended by the competent authority as defined in ADR.AR.C.055(c)(2).~~

~~The oversight planning cycle may be further extended to a maximum of 48 months if, in addition to the above, the aerodrome operator has established, and the competent authority has approved, an effective continuous reporting system to the competent authority on the safety performance and regulatory compliance of the aerodrome operator itself.~~

~~(c) For aerodrome operators operating more than one aerodrome in order to avoid duplication of audits, credit may be granted for specific item audits already completed during the current oversight planning cycle subject to the following conditions:~~

- ~~(1) there should be satisfactory evidence on record that such specific item audits were carried out and that all corrective actions have been taken; and~~
- ~~(2) the competent authority should be satisfied that there is no reason to believe standards have deteriorated in respect of those specific item audits being granted a credit; and~~
- ~~(3) the specific item audit being granted a credit should be audited not later than 24 months after the last audit of the item.~~

~~(a) During each oversight planning cycle, meetings with the management of the aerodrome operator, including the accountable manager or its high level delegate, as determined necessary by the competent authority, should take place in order to ensure that both parties remain informed of significant issues).~~

~~AMC2~~ **ADR.AR.C.010(b) – Oversight programme**

AUDITS, INSPECTIONS AND OVERSIGHT PROCEDURES

- (a) Each aerodrome operator, and each declared provider of apron management services should have an appropriate focal point specifically assigned to it in the ~~competent authority~~ **Competent Authority**. Where more than one aerodrome inspector is assigned to an aerodrome operator, one of them should be nominated as having overall responsibility for supervision of, and liaison with the aerodrome operator's management, and be responsible for reporting on compliance with the requirements for its operations as a whole.
- (b) Inspections, audits, and oversight procedures, on a scale and frequency appropriate to the operation, should include, but not be limited to, items from the following ~~indicative~~ list:
 - (1) aerodrome infrastructure and equipment;
 - (2) visual aids and aerodrome electrical systems;
 - (3) obstacle restriction and control;

AMC/GM to Annex I – Part-AR

SUBPART C – OVERSIGHT, CERTIFICATION AND ENFORCEMENT (ADR.AR.C)

- (4) aerodrome data reporting ;
 - (5) aerodrome emergency planning;
 - (6) rescue and ~~fire-fighting~~firefighting;
 - (7) removal of disabled aircraft;
 - (8) storage facilities and handling of dangerous goods and fuel, including fuel installations, fuel quality, and fuelling equipment;
 - (9) low visibility operations;
 - (10) winter and adverse weather operations;
 - (11) protection of radar, navigation aids, and other aerodrome equipment;
 - (12) apron management;
 - (13) apron safety management;
 - (14) vehicle control on the movement area;
 - (15) wildlife hazard management;
 - (16) inspections of the movement area;
 - (17) maintenance of the aerodrome systems and the movement area;
 - (18) aerodrome works;
 - (19) protection against hazardous activities in the vicinity of the aerodrome;
 - (20) personnel training and records;
 - (21) aerodrome manuals and documentation;
 - (22) operator's management system, including its safety management system and its quality, and security management system for aeronautical data; and
 - (23) operator's oversight of the compliance of the organisations operating, or providing services at the aerodrome (third parties).
- (c) An inspection or an audit should be a 'deep cut' through the items selected, and all findings and observations should be recorded.
- (d) Aerodrome inspectors should analyse and assess the root cause(s) identified by the aerodrome operator, and be satisfied that the corrective actions taken are adequate to correct the non-compliance, and to prevent ~~re-occurrence~~reoccurrence.
- (e) Inspections and audits may be conducted separately or in combination. Inspections and audits may also be coordinated with inspections and audits conducted by the competent authorities responsible for ~~the other~~ other areas of ATM/ANS, to address areas of coordination between aerodrome operator and ~~ATM~~the providers of other services (e.g. ATM/ANS). Inspections may, at the discretion of the ~~competent authority~~Competent Authority, be conducted with or without prior notice to the aerodrome operator, or the provider of apron management services. Unannounced inspections should not disrupt fluent and safe operations of the aerodrome.
- (f) Where it is apparent to an aerodrome inspector that an aerodrome operator, or a provider of apron management services has permitted a breach of the applicable requirements, with the result that safety has been, or might have been compromised, the inspector should ensure that the responsible person within the ~~competent authority~~Competent Authority is informed without delay.

AMC/GM to Annex I – Part-AR

SUBPART C – OVERSIGHT, CERTIFICATION AND ENFORCEMENT (ADR.AR.C)

- (g) In the first few months of a new operation, physical change of the aerodrome or organisational ~~re-structure~~restructure, aerodrome inspectors should be particularly alert to any irregular procedures, evidence of inadequate facilities or equipment, or indications that management control of the operation may be ineffective.

~~The~~Aerodrome inspectors should take account of any conditions that may indicate a significant deterioration in the operator's financial situation. ~~Examples of trends which may indicate problems in a new aerodrome operator's financial situation could be:~~

- (1) ~~significant lay offs or turnover of personnel; reduced staff resource; increased multi-tasking; changing shift patterns; increased overtime;~~
- (2) ~~delays in meeting payroll;~~
- (3) ~~reduction of safe operating standards;~~
- (4) ~~decreasing standards of training;~~
- (5) ~~withdrawal of credit by suppliers;~~
- (6) ~~inadequate maintenance of the aerodrome; and~~
- (7) ~~shortage of supplies and spare parts.~~

When any financial difficulties are identified, aerodrome inspectors should increase technical surveillance of the operation with particular emphasis on the upholding of safety standards.

- (h) The number or the magnitude of the non-compliances identified by the ~~competent authority~~Competent Authority will serve to support the ~~competent authority's~~Competent Authority's continuing confidence in the aerodrome operator's, or the of apron management services provider's competence, or, alternatively, may lead to an erosion of that confidence. In the latter case, the ~~competent authority~~Competent Authority will need to review any identifiable shortcomings of the management system, and take appropriate action if required.

AMC1- ADR.AR.C.010(b) to (e) Oversight programmeOVERSIGHT PLANNING CYCLE

- (a) The safety performance should be continuously monitored in order to ensure that the oversight programme and the applicable oversight planning cycle remain appropriate.
- (b) The oversight planning cycle and related oversight programme for each aerodrome operator should be reviewed annually.
- (c) The oversight planning cycle and related oversight programme, and their annual review should be determined according to the following elements:
- (1) the results of past certification and oversight activities;
 - (2) capability to effectively identify aviation safety hazards, and manage the associated risks;
 - (3) effective control over all changes in accordance with ADR.OR.B.040;
 - (4) absence of level 1 findings;
 - (5) response time to implement corrective actions requested by the Competent Authority in accordance with ADR.AR.C.055(d)(2); and

AMC/GM to Annex I – Part-AR

SUBPART C – OVERSIGHT, CERTIFICATION AND ENFORCEMENT (ADR.AR.C)

- (6) risk exposure related to the aerodrome operated, such as traffic volume, type of aircraft or physical characteristics of the aerodrome.
- (d) During each oversight planning cycle, the competent authority should convene meetings with the accountable manager of the aerodrome operator, or his/her delegate.

AMC/GM to Annex I – Part-AR

SUBPART C – OVERSIGHT, CERTIFICATION AND ENFORCEMENT (ADR.AR.C)

AMC1 ADR.C.010(b) Oversight programmeOVERSIGHT PLANNING CYCLE

- (b) For each aerodrome operator certified by the Competent Authority all processes should be audited at periods not exceeding the applicable oversight planning cycle. The beginning of the first oversight planning cycle is normally determined by the date of issue of the first certificate. If the Competent Authority wishes to align the oversight planning cycle with the calendar year, it should shorten the first oversight planning cycle accordingly.
- (c) The interval between two audits for a particular process should not exceed the interval of the applicable oversight planning cycle.
- ~~(b)~~(d) Audits should include at least one on-site audit within each oversight planning cycle at each aerodrome.

AMC2); (e) — ADR.AR.C.010(b) Oversight programmeAUDIT

- (a) The oversight programme should indicate which aspects will be covered with each audit.
- (b) Part of an audit should concentrate on the aerodrome operator's compliance monitoring reports ~~produced by its compliance monitoring personnel~~ to determine if the aerodrome operator is identifying the root causes ~~of~~ and correcting its problems.
- (c) At the conclusion of the audit, an audit report should be completed by the auditing aerodrome inspector, including all findings raised.

AMC2-GM1 ADR.AR.C.010(b) — Oversight programmeAUDITS AND INSPECTIONS

- ~~(a) The competent authority should establish a schedule of audits and inspections appropriate to each aerodrome operator or provider of apron management services. The planning of audits and inspections should take into account the results of the hazard identification and risk assessments conducted and maintained by the aerodrome operator as part of its management system. Aerodrome inspectors should work in accordance with the schedule provided to them.~~
- ~~(b) The competent authority may, having regard to an aerodrome operator's performance, vary the frequency of an audit or inspection while ensuring that all aspects of the operation are periodically audited and inspected in accordance with the schedule.~~
- ~~(c) When defining the oversight programme, the competent authority should assess the risks related to the activity of each aerodrome operator or provider of apron management services and adapt the oversight means to the level of risk identified.~~

GM2-ADR.AR.C.010(b) —);(c) Oversight programmeINDUSTRY STANDARDS

AMC/GM to Annex I – Part-AR

SUBPART C – OVERSIGHT, CERTIFICATION AND ENFORCEMENT (ADR.AR.C)

- (a) For aerodrome operators having demonstrated compliance with industry standards, the ~~competent authority~~ Competent Authority may adapt its oversight programme₇ in order to avoid duplication of audits.
- (b) Demonstrated compliance with industry standards may not be considered in isolation from the other elements to be considered for the ~~competent authority's~~ Competent Authority's risk-based oversight.
- (c) In order to be able to credit any audits performed as part of certification in accordance with industry standards, the following should be considered:
- (1) the demonstration of compliance is based on certification auditing schemes providing for independent and systematic verification;
 - (2) the existence of an accreditation scheme and accreditation body for certification in accordance with the industry standards has been verified;
 - (3) certification audits are relevant to the requirements defined in Part-ADR.OR, Part ADR.OPS_x or other regulations as applicable;
 - (4) the scope of such certification audits can easily be mapped against the scope of oversight;
 - (5) audit results are accessible to the ~~competent authority~~ Competent Authority; and
 - (6) the audit planning intervals are compatible with the oversight planning cycle.

GM3-GM2 ADR.AR.C.010(b) Oversight programme**AUDITS, INSPECTIONS AND OVERSIGHT PROCEDURES**

Examples of trends which may indicate problems in a new aerodrome operator's financial situation could be:

- (8) significant lay-offs or turnover of personnel; reduced staff resource; increased multi-tasking; changing shift patterns; and increased overtime;
- (9) delays in meeting payroll;
- (10) reduction of safe operating standards;
- (11) decreasing standards of training;
- (12) withdrawal of credit by suppliers;
- (13) inadequate maintenance of the aerodrome; and
- (14) shortage of supplies and spare parts.

GM3 ADR.AR.C.010(b) Oversight programme**AUDITS, INSPECTIONS AND OVERSIGHT PROCEDURES**

Normally the inspections that are carried out by the ~~competent authority~~ Competent Authority should be with prior notice to the aerodrome operator or the provider apron management services.

Such notice should be given in writing_x and in good time before the inspection₇, so that the inspected entity can make all the necessary arrangements and preparations_x and to avoid the disruption of normal operations.

AMC/GM to Annex I – Part-AR

SUBPART C – OVERSIGHT, CERTIFICATION AND ENFORCEMENT (ADR.AR.C)

In case an inspection is conducted without prior notice, (unannounced inspection), the aerodrome inspectors should ensure that the operations are affected to the minimum extent possible.

~~AMC1-AMC2~~ **ADR.AR.C.015(a) — Initiation of the certification process**

~~ELIGIBILITY CRITERIA~~

~~In the case where the application is refused because the applicant does not meet the eligibility criteria, the competent authority should inform the applicant in writing of the right of appeal, as exists under the applicable national legislation.~~

~~AMC1-ADR.AR.C.015(a)~~ **Initiation of the certification process**

PROCESSING OF APPLICATION

Upon receipt of an application, the ~~competent authority~~ Competent Authority should acknowledge receipt of that application, in writing, within the period defined in the applicable national legislation.

If the ~~competent authority~~ Competent Authority foresees a delay in processing the application, it should notify the applicant as soon as possible, and within the period defined in the applicable national legislation.

The ~~competent authority~~ Competent Authority should respond to any request made by the applicant within the period defined in the applicable national legislation.

If an applicant fails to submit all necessary documentation, the ~~competent authority~~ Competent Authority should inform him/her in writing, within the period defined in the applicable national legislation.

AMC1-ADR.AR.C.015(b)(1);(2) – Initiation of the certification process

NOTIFICATION OF CERTIFICATION BASIS

- (a) Upon receipt of the application, the ~~competent authority~~Competent Authority should examine and assess the content of the application and the related documentation, including the proposed ~~certification specifications~~Certification Specifications and any provisions for which compliance is proposed to be demonstrated in ~~an alternative~~a different way that provides for an equivalent level of safety. (See also paragraph 1 (a) of AMC1-ADR.AR.C.035(a);(b)).
- (b) The ~~competent authority~~Competent Authority should establish the certification basis of the aerodrome, which should include:
- (1) all ~~certification specifications~~Certification Specifications that it finds applicable to the aerodrome design and operation;
 - (2) any provision for which the ~~competent authority~~Competent Authority is satisfied with the proposal, and accepts the applicant to demonstrate an equivalent level of safety (ELOS) based on its application; and
 - (3) any special condition prescribed in accordance with ADR.AR.C.025, that the ~~competent authority~~Competent Authority finds necessary to be included in the certification basis.
- (c) The ~~competent authority~~Competent Authority should document and notify the applicant of:
- (1) the certification basis as established in paragraph (b) above; and
 - (2) any change thereto, as a result of ~~certification specifications~~Certification Specifications which became effective after the notification of the certification basis and which the applicant decided to comply with, or that the ~~competent authority~~Competent Authority has found necessary to be complied with, or design changes made, compliance demonstration results, new special conditions that the ~~competent authority~~Competent Authority considers necessary, etc.
- (d) In addition, the ~~competent authority~~Competent Authority should assess the documentation demonstrating the way the applicant is proposing to comply with the applicable requirements of the ~~Basic Regulation (EC) 216/2008~~, Part-ADR.OR, and Part-ADR.OPS, and any other applicable requirements that are matching the aerodrome design and its operation. ~~The competent authority should also:~~
- ~~(1) examine any request of the applicant for exemption or derogation from any requirement in accordance with article 14 of the Basic Regulation; and~~
 - ~~(2) evaluate, in accordance with ADR.AR.A.015, any request of the applicant for use of alternative means of compliance.~~
- ~~(e) The competent authority should take all necessary actions in accordance with article 14 of the Basic Regulation and its Implementing Rules and, as appropriate, document and notify the applicant:~~
- ~~(1) the approved mitigation measures for ensuring that the level of safety is not adversely affected in the case of an exemption under article 14 paragraph 4 of the Basic Regulation; and the approved means for demonstrating an equivalent level of protection in the case of derogations under article 14 paragraph 6 of the Basic Regulation for the exemptions and derogations mentioned in paragraph (d)(1) above;~~

AMC/GM to Annex I – Part-AR

SUBPART C – OVERSIGHT, CERTIFICATION AND ENFORCEMENT (ADR.AR.C)

~~(2) the alternative means of compliance whose use have been accepted, mentioned in paragraph (d)(2) above; and~~

~~(3) any subsequent changes concerning subparagraphs (d)(1) or (d)(2) above, as a result of changes to the proposed operation and design, new determinations made by the competent authority or new requests made by the applicant etc.~~

~~(f)(e)~~ When notifying the applicant in accordance with ~~paragraphs~~paragraph (c) ~~and (e)~~, the ~~competent authority~~Competent Authority should also inform him/her of the right of appeal, as ~~exist~~exists under the applicable national legislation.

AMC1-ADR.AR.C.015(b);(1) – Initiation of the certification processNOTIFICATION OF CERTIFICATION BASIS – DETERMINATION OF ELEVATION OF AERONAUTICAL BEACONS

~~The competent authority should determine~~If such beacons are operationally necessary, the Competent Authority should ensure that the elevation which is sufficient for the vertical light distribution of an aerodrome beacon or an identification beacon, as described in CS-ADR-DSN.M.625-620, is determined.

AMC2-ADR.AR.C.015(b);(1) – Initiation of the certification processRUNWAY LEAD-IN LIGHTING SYSTEM

~~If a runway lead-in lighting system is provided, the competent authority should determine the point from which that system should extend up to the point where the approach lighting system, or the runway or the runway lighting system is in view.~~

AMC3-ADR.AR.C.015(b);(1) – Initiation of the certification processELECTRICAL POWER SUPPLY SYSTEMS FOR VISUAL AIDS.

~~The competent authority should determine which obstacle lights are essential for the aerodrome to ensure the safe operation of aircraft and should therefore be provided with a secondary power supply capable of supplying power when there is a failure of the primary power supply.~~

AMC4-ADR.AR.C.015(b);(1) – Initiation of the certification processMONITORING SYSTEM

~~The competent authority should determine the serviceability level of any element of the lighting systems of a runway meant for takeoff for use in runway visual range conditions less than a value of 550 m, below which operations should not continue, in accordance with CS-ADR-DSN.S.900 and CS-ADR-DSN.S.905.~~

AMC5-ADR.AR.C.015(b);(1) – Initiation of the certification processCOLOURS OF AERONAUTICAL GROUND LIGHTS

AMC/GM to Annex I – Part-AR

SUBPART C – OVERSIGHT, CERTIFICATION AND ENFORCEMENT (ADR.AR.C)

- (a) ~~The competent authority should review and judge the acceptability of the outermost isocandela curve, for which a measurement of colour coordinates should be made and recorded by the aerodrome operator.~~
- (b) ~~Certain light units may have application so that they may be viewed and used by pilots from directions beyond that of the outermost isocandela curve (e.g. stop bar lights at significantly wide runway holding positions). In such instances, the competent authority should assess the actual application and if necessary require a check of colour shift at angular ranges beyond the outermost curve.~~

AMC1-GM1 ADR.AR.C.015(c) – Initiation of the certification process

CERTIFICATION OF EXISTING AERODROMES

The certification period of an existing aerodrome should not exceed 18 months ~~since~~from the ~~filing~~filing of the application by the applicant to the granting of the certificate.

GM1-ADR.AR.C.015 – Initiation of the certification process

INITIAL INTEREST

Prior to initiating the application process for a certificate, ~~the competent authority~~Competent Authority should arrange for a meeting with the applicant.

During this meeting, the applicant should present to the authority its plans with regard to the aerodrome. The applicant should also make arrangements so that its key personnel are present during this meeting.

In addition, during this meeting, the ~~competent authority~~Competent Authority should provide general information to the applicant about the applicable requirements for the aerodrome. It should also provide copies of the applicable requirements, application forms, ~~and any other relevant documentation,~~ and describe the procedures that are followed during the certification process.

Such information to be provided by the ~~competent authority~~Competent Authority may also include information about approvals, permits, ~~or clearances that the applicant may need to obtain from other competent authorities (such as security or environmental protection competent authorities, local planning authorities, etc).~~ of the Member State prior or during the certification process.

The ~~competent authority~~Competent Authority should make arrangements so that representatives of all involved entities of the ~~competent authority~~Competent Authority(ies) are present during this meeting.

GM2-GM1 ADR.AR.C.015(b)-(1);(2) – Initiation of the certification process

CERTIFICATION BASIS – PROPOSALS FOR EQUIVALENT LEVEL OF SAFETY

When the ~~competent authority~~Competent Authority assesses a proposal of an applicant who has requested to demonstrate an equivalent level of safety ~~(ELOS),~~ the ~~competent authority~~Competent Authority should pay, amongst others, particular attention to:

- (a) the identification of the intent of the Agency's ~~certification specification~~Certification Specification(s) in question, ~~and assess if the proposal satisfies that intent;~~

AMC/GM to Annex I – Part-AR

SUBPART C – OVERSIGHT, CERTIFICATION AND ENFORCEMENT (ADR.AR.C)

(b) any possible interconnections/relationships between the Agency's ~~certification specification~~Certification Specification(s) which the proposal is related to, with any other ~~certification specifications~~Certification Specifications or requirements, in order to ~~identify any implications of the proposal to other design, operational, human or other elements of the system and to establish if such interconnections/relationships and implications have been addressed.~~;

(1) identify any implications of the proposal to other design, operational, human, or other elements of the system; and

(2) establish if such interconnections/relationships and implications have been properly and adequately addressed by the applicant.

The applicant's proposal may involve design, technical, procedural, or other suitable means.

The demonstration of an equivalent level of safety may involve various methodologies, quantitative or qualitative, whose magnitude and complexity may vary, depending on each case.

In any case, the applicant should demonstrate to the satisfaction of the Competent Authority that the proposed solution offers a level of safety, which is effectively not lower than that associated with the relevant Agency Certification Specification(s).

AMC1-ADR.AR.C.020 – Certification Basis

EFFECTIVE CERTIFICATION SPECIFICATIONS

- (a) The ~~certification—specifications~~Certification Specifications that the ~~competent authority~~Competent Authority should use to establish and notify the certification basis to the applicant, should be those that were effective during the date of the application.
- (b) Notwithstanding paragraph (a) above, if at any point of the certification process the applicant requests to use ~~certification—specifications~~Certification Specifications which came into force after the filing of his/her application, or the notification of the certification basis by the ~~competent authority~~Competent Authority, then the ~~competent authority~~Competent Authority should examine if it is necessary to also include in the certification basis other ~~certification—specifications~~Certification Specifications, which also came into effect after the filling of the initial application and which are, in the opinion of the ~~competent authority~~Competent Authority, directly related to those ~~certification specifications~~Certification Specifications that have been proposed by the applicant.
- (c) Notwithstanding paragraph (a) and (b) above, the ~~competent authority~~Competent Authority may at any time, after the filing of the application, decide to include in the certification basis any ~~certification—specifications~~Certification Specifications that it deems necessary.

AMC1-GM1 ADR.AR.C.035(a)(2) – Issuance of certificateEVALUATION OF SAFETY ASSESSEMENTS PROVIDED BY THE AERODROME OPERATOR AT THE INITIAL CERTIFICATION OR ACCOMPANYING A REQUEST FOR PRIOR APPROVAL OF A CHANGE IN ACCORDANCE WITH ADR.OR.B.040.

- (a) The ~~competent authority~~Competent Authority should ~~validate~~evaluate the conclusion of a ~~submitted~~ safety assessment, provided by the aerodrome operator, to ensure compliance with the ~~applicable requirements (see relevant requirement for the operator on how to assess changes under~~ ADR.OR.B.065040(f).
- (b) The ~~competent authority~~Competent Authority should ~~analyse~~evaluate the safety assessment and, in particular, make sure that:
- (1) the identified safety concern(s) has ~~not~~ (have) been assessed through the safety assessment process and is ~~not~~ (are) adequately documented.
 - (2) an appropriate coordination has been performed between the parties affected by the safety concern(s);
 - (3) the assessment covers the whole system and the interactions of its elements;
 - (4) the hazards have been properly identified and the level of risk assessed;
 - (5) the proposed mitigation measures are adequate and consistent with the objective of reducing the identified level of risk and the safety objectives, if relevant;
 - (6) the timeframes of the planned implementation of the ~~any proposed~~ associated actions are appropriate.
- (c) ~~The competent authority~~After its evaluation, the Competent Authority should either:
- (1) ~~give approval~~agree to the aerodrome operator for the safety assessment and the proposed associated actions, such as mitigation measures; or
 - (2) coordinate with the aerodrome operator to reach an agreement on revised

AMC/GM to Annex I – Part-AR

SUBPART C – OVERSIGHT, CERTIFICATION AND ENFORCEMENT (ADR.AR.C)

mitigation measures if some risks have been underestimated, or have not been identified; or

(3) impose additional measures, or reject the proposal if no agreement can be reached.

(d) The ~~competent authority~~ Competent Authority should define and undertake oversight actions that ensure that ~~the~~ mitigation and/or additional measures are properly implemented so that the measures actually meet the risk reduction objectives, and that the planned timeframes are applied.

~~(e) The approval of the safety assessments should be undertaken by the competent authority and notified to the aerodrome operator along with the approval of the change, if such prior approval is required.~~

~~(f)~~ (e) When necessary, the ~~competent authority~~ Competent Authority should require the aerodrome operator to promulgate appropriate information, for use by the aerodrome organisation, various stakeholders, and notably by the air navigation service providers and aircraft operators.

~~AMC1-~~

GM1 ADR.AR.C.035(b)(1) Issuance of certificate

MODEL FOR THE SINGLE CERTIFICATE

[MEMBER STATE]

A Member of the European Union¹

CERTIFICATE

Certificate reference: [STATE CODE]: xxxxx

Pursuant to Regulation (EC) No 216/2008 of the European Parliament and of the Council and the Commission Regulation (EC) No .../... for the time being in force and subject to the conditions specified below, [THE COMPETENT AUTHORITY OF THE MEMBER STATE²] hereby certifies that:

[COMPANY NAME AND ADDRESS]

is authorised to operate aerodrome [NAME OF AERODROME], in accordance with the provisions of Regulation (EC) No 216/2008 and its Implementing Rules, the aerodrome certification basis, the terms of the certificate and the aerodrome manual.

This certificate shall remain valid for an unlimited duration, unless it is surrendered or revoked.

Date of original issue:.....

Revision No:.....

Signed:.....

For the Competent Authority[COMPETENT AUTHORITYIDENTIFICATION]

¹ Delete for non-EU Member States.

² Delete for non-EU Member States.

GM2 ADR.AR.C.035 (b) (2) Issuance of certificate

MODEL FOR THE TWO SEPARATE CERTIFICATES – (A)~~);(b)~~ – AERODROME OPERATOR CERTIFICATE

[MEMBER STATE]

A Member of the European Union³

AERODROME OPERATOR CERTIFICATE

Certificate reference: [STATE CODE]: xxxxx

Pursuant to Regulation (EC) No 216/2008 of the European Parliament and of the Council and the Commission Regulation (EC) No .../... for the time being in force and subject to the conditions specified below, [THE COMPETENT AUTHORITY OF THE MEMBER STATE⁴] hereby certifies that:

[COMPANY NAME AND ADDRESS]

is authorised to operate aerodrome [NAME OF AERODROME(S)]⁵, in accordance with the provisions of Regulation (EC) No 216/2008 and its Implementing Rules, the aerodrome certification basis, the terms of the certificate attached to the aerodrome certificate and its aerodrome manual.

Apron management services are provided by [specify name of service provider].
This certificate shall remain valid for an unlimited duration, unless it is surrendered or revoked.

Date of original issue:.....

Revision No:.....

Signed:.....

For the Competent Authority [COMPETENT AUTHORITY IDENTIFICATION]

3 Delete for non-EU Member States.

4 Delete for non-EU Member States.

5 Delete as appropriate. If the operator operates more than one aerodrome, all aerodromes shall be listed.

MODEL FOR THE TWO SEPARATE CERTIFICATES – (B) AERODROME CERTIFICATE

[MEMBER STATE]

A Member of the European Union⁶

AERODROME CERTIFICATE

Certificate reference: [STATE CODE]: xxxxx

Pursuant to Regulation (EC) No 216/2008 of the European Parliament and of the Council and the Commission Regulation (EC) No .../... for the time being in force and subject to the conditions specified below, [THE COMPETENT AUTHORITY OF THE MEMBER STATE] hereby certifies that:

[NAME OF AERODROME⁷]

is authorised to be operated as an aerodrome by [AERODROME OPERATOR COMPANY NAME AND ADDRESS], in accordance with the provisions of Regulation (EC) No 216/2008 and its Implementing Rules, the aerodrome certification basis, the terms of the certificate attached to this aerodrome certificate and the aerodrome manual.

This certificate shall remain valid for an unlimited duration, unless it is surrendered or revoked.

Date of original issue:.....

Revision No:.....

Signed:.....

For the Competent Authority [COMPETENT AUTHORITY IDENTIFICATION]

⁶ Delete for non-EU Member States.

⁷ Delete as appropriate.

GM3 ADR.AR.C.035(b)(1):(2) Issuance of certificate**MODEL FOR THE TERMS OF THE CERTIFICATE TO BE ATTACHED TO THE CERTIFICATE**

<u>TERMS OF THE CERTIFICATE</u>	
<u>Certificate reference: [STATE CODE] ¹:</u>	
<u>Aerodrome name – ICAO location indicator ²:</u>	
<u>Conditions to operate ³:</u>	
<u>Runway – declared distances ⁴:</u>	
<u>Types of approaches ⁵:</u>	
<u>Aerodrome Operating minima ⁶:</u>	
<u>Aerodrome reference code⁷:</u>	
<u>Scope of aircraft operations with a higher aerodrome reference code letter ⁸:</u>	
<u>Provision of apron management services ⁹:</u>	
<u>Rescue and firefighting level of protection ¹⁰:</u>	
<u>Other¹¹</u>	

1. The certificate must be given the State Code [The two-letter ISO code should be used (ISO 3166 alpha-2), except for Greece and the United Kingdom, for which the abbreviations EL and UK are recommended] and a unique ascending number. Example: EL – 001

2. To be specified: the official name of the aerodrome and the ICAO location indicator for the aerodrome.

3. To be specified: day/ night and IFR/ VFR.

4. To be specified: ASDA, LDA, TODA, TORA in metres for each direction of each runway, including intersection take-off if applicable.

AMC/GM to Annex I – Part-AR

SUBPART C – OVERSIGHT, CERTIFICATION AND ENFORCEMENT (ADR.AR.C)

5. To be specified: approval of the runway for non-instrument, instrument, non-precision approach. In case of precision approach (-es) it is to be indicated, which of the following precision approach (-es) is (are) approved:

- Standard Category I;
- Lower than Standard Category I;
- Precision Approach Category II;
- Other than Standard Category II;
- Precision Approach Category III-A;
- Precision Approach Category III-B;
- Precision Approach Category III-C.

6. To be specified: the operating minima.

7. To be specified: Aerodrome Reference Code (Code number/Code letter).

8. To be specified: the approved operations of aeroplanes with a higher code letter than indicated in point 7 above.

9. To be specified: the name of service provider if such services are not provided by the aerodrome operator.

10. To be specified: the rescue and firefighting level of protection as per Annex III (PART-ADR.OPS) of this Regulation.

11. To be specified: any other information that the Competent Authority finds necessary to include.

AMC1 ADR.AR.C.035(c) Issuance of certificate

VERIFICATION OF COMPLIANCE

- (a) Upon receipt of an application for a certificate, the ~~competent authority~~Competent Authority should:
- (1) nominate an individual, to become the focal point for all aspects of the applicant's certification process, and to coordinate all necessary activities, including the ~~competent authority's~~Competent Authority's certification team. The nominated person should be responsible to the responsible person of the ~~competent authority~~Competent Authority for confirming that all appropriate inspections and audits have been carried out. He/she should also ensure that the necessary prior approvals required are issued in due course.;
 - (2) verify if the application shows compliance with the applicable requirements. The ~~competent authority~~Competent Authority should also arrange for the steps to be followed during the certification process. This would, normally, start with the demonstration of compliance of the aerodrome with the notified certification basis

AMC/GM to Annex I – Part-AR

SUBPART C – OVERSIGHT, CERTIFICATION AND ENFORCEMENT (ADR.AR.C)

(see AMC1 —~~ADR.AR.C.015(b);(1);(2);~~) which will require the conduct of technical inspections by the ~~competent authority~~ Competent Authority and/or examination of submitted documentation, the participation to demonstrations, or tests conducted by the applicant, as the case may be, and the ~~competent authority~~ Competent Authority determines appropriate. This should also include the cases where the certification basis includes provisions for which the ~~competent authority~~ Competent Authority has accepted the applicant to demonstrate an equivalent level of safety to, or cases of special conditions, as applicable;

If the ~~competent authority~~ Competent Authority is not satisfied with the outcome of the demonstration process for any elements of the certification basis, it should notify the applicant in writing. At the end of this phase, the ~~competent authority~~ Competent Authority should have documented evidence that the aerodrome meets the notified certification basis;

- (3) review the aerodrome manual, which should be prepared in accordance with ADR.OR.D.005, and any other documentation provided by the applicant; and
- (4) verify compliance with the applicable requirements of Part-ADR.OR, Part-ADR.OPS, as well as any other applicable requirement. When verifying compliance with such requirements, an audit should be conducted covering the following areas:
 - (i)- compliance shown by the applicant with the applicable requirements of Part-ADR.OPS, or any other applicable requirements;
 - (ii)- the applicant's management system and its organisation, including: detailed management structure, including names and qualifications of nominated personnel; adequacy of the organisation and management structure, including allocated resources and numbers of personnel allocated by the applicant to key management tasks and other positions. Care should be taken to verify that the system is comprehensive, and is likely to be effective. Of particular importance is a careful review of the qualifications of the applicant's nominated persons. Account should be taken of the relevance of the nominee's previous experience and known record;
 - (iii)- safety management and compliance monitoring with applicable requirements;
 - (iv) documentation on which the certificate ~~shall~~ should be granted (organisation documentation as required by Part-ADR.OR, including technical manuals, such as the aerodrome manual etc.); and
 - (v)- adequacy of facilities with regard to the applicant's scope of work.
- (5) in case of non-compliance, the applicant should be informed, in writing, of the corrections or supplements which are required.

~~(b)~~ The Competent Authority should be satisfied with the demonstration of compliance of the aerodrome manual with the requirements referred to in ADR.OR.E.005 and the related AMCs.

~~(b)~~ (c) The Competent Authority should ensure that standardised and approved methods and tools are used by its personnel during the process described in paragraph 1a.

~~(e)~~ (d) In cases where an application for a certificate is refused, the applicant should be informed of the right of appeal as existing under national regulations.

~~(d)~~ (e) Prior to issuing the certificate(s), the Competent Authority may require the conduct of one or more flights at the aerodrome, as well as any other test, or exercise it finds necessary.

AMC/GM to Annex I – Part-AR

SUBPART C – OVERSIGHT, CERTIFICATION AND ENFORCEMENT (ADR.AR.C)

(e)(f) When the verification process is complete, the ~~competent authority~~ Competent Authority should issue the certificate(s) and ensure the publication of the certification status of the aerodrome in the aeronautical information publication (AIP) in section AD.1.5.

GM1-ADR.AR.C.035 – Issuance of certificate

VERIFICATION OF COMPLIANCE

The technical inspections of the aerodrome ~~prescribed in paragraphs (b) and (d)(i) of AMC1-ADR.AR.C.035 (a);(b)~~ should take place prior to the ~~approval of Competent Authority finding~~ the aerodrome manual satisfactory in accordance with ADR.OR.E.005.

AMC1-ADR.AR.C.035(a)(~~3~~) – Issuance of certificate

NOMINATED PERSONS

When an aerodrome operator submits the name of a nominee for the nominated persons ~~listed~~ mentioned in ADR.OR.D.015, the ~~competent authority~~ Competent Authority should assess his/her qualifications and may interview the nominee or call for additional evidence of his/her suitability before deciding upon his/her acceptability.

GM1-ADR.AR.C.035(a)(~~3~~) – 2) Issuance of certificate

NOMINATED PERSONS

Interview with the Accountable Manager, ~~Safety Manager, Compliance Monitoring Manager~~ and other nominated persons ~~mentioned in ADR.OR.D.015.~~

~~There are two possible~~ Possible cases where an interview/ meeting with nominated post holders may be necessary; are amongst others:

- (a) start of operations before issuing a first certificate for an aerodrome; and
- (b) change of nominated persons at an aerodrome already certified.

Purpose of the meeting:

The aim of the interview and exchange of information between the intended nominated persons and the ~~competent authority~~ Competent Authority is, for the ~~competent authority~~ latter to acquire information on the intended work areas of the nominated persons and their respective competence level ~~and give information about the competent authority and at the same time so as to~~ verify their suitability for the posts.

The purpose of the information exchange is to create good contact and understanding between the both parties, and to come to a mutual conclusion on, if necessary, possible solutions for training and personal development over time.

Possible agenda items:

- (a) information from the ~~competent authority~~ Competent Authority on organisation and mission of the ~~competent authority~~ Competent Authority, the regulatory framework, and specifically Safety Management System requirements;
- (b) information from the nominated person concerning the intended work area;
- (c) enforcement methodology of the ~~competent authority~~ Competent Authority;
- (d) the role and responsibility of the ~~Accountable Manager/Chief Operating Officer/Safety Coordinator~~ accountable manager/chief operating officer/safety coordinator or other nominated post holders;
- (e) expected competence requirement of the nominated person in relation to present personal status and experience presented in a CV or equivalent documentation;

AMC/GM to Annex I – Part-AR

SUBPART C – OVERSIGHT, CERTIFICATION AND ENFORCEMENT (ADR.AR.C)

- (f) interview/discussion concerning depth of knowledge_z and understanding of the applicable legislation;
- (g) the role and responsibility of the ~~competent authority~~ Competent Authority and of the nominated person;
- (h) understanding of aviation in general and for the specific nominated post, how operators/activities at the aerodrome including Air Navigation Service Providers, and other aviation activities can impact aircraft safety; and
- (i) distribution of delegated powers depending on the organisational situation.

AMC1-ADR.AR.C.035(~~db~~)(1);(2) – Issuance of certificate

ISSUANCE OF SEPARATE CERTIFICATES

- (a) In ~~the case that~~ there is a possibility to issue both separate and single certificates, the ~~competent authority~~ Competent Authority should act in accordance with the application made by the applicant.
- (b) In ~~the case that~~ there is a possibility to issue separate certificates, both certificates should be issued by the same ~~competent authority~~ Competent Authority.
- (c) In case that an aerodrome operator operates several aerodromes, these ~~shall~~ should be listed on the aerodrome operator's certificate.

AMC1-ADR.AR.C.035(~~f~~—d) Issuance of certificateOPERATING CONDITIONS OR LIMITATIONS AND PROCEDURES

- (a) If, during the certification process, an operating condition or a limitation or ~~an operating procedure~~ has been determined as necessary to be imposed on or implemented at the aerodrome, the ~~competent authority~~ Competent Authority should ensure that such limitation or procedure is also included in the aerodrome manual.
- (b) The ~~competent authority~~ Competent Authority should also ensure that the aerodrome manual contains all limitations_z or any other similar information prescribed in the certification specifications included in the certification basis of the aerodrome.

AMC1-ADR.AR.C.035(g) – Issuance of certificateAPPROVAL OF THE PROCEDURE FOR THE MANAGEMENT AND NOTIFICATION OF CHANGES

The ~~competent authority~~ Competent Authority should establish and document its process to be followed by the aerodrome inspectors when assessing the scope of the changes ~~and in~~ the procedure proposed by the aerodrome operator to be followed for the management and notification of the changes. Criteria to be used include_z but are not limited to:

- (a) frequency of changes;
- (b) magnitude of changes;
- (c) complexity of the aerodrome and type of operations;
- (d) density of traffic at the aerodrome;

AMC/GM to Annex I – Part-AR

SUBPART C – OVERSIGHT, CERTIFICATION AND ENFORCEMENT (ADR.AR.C)

- (e) time required to assess the documentation of the changes notified by the aerodrome operator;
- (f) reasonable reaction times in relation to types of changes for the competent authority to object to a notification;
- ~~(f)~~(g) need for the timely publication of the changes and their notification by the AIRAC system;
- ~~(g)~~(h) previous conduct of the aerodrome operator; and
- ~~(h)~~(i) effectiveness of the safety management system of the aerodrome operator.

AMC1-ADR.AR.C.040~~(a)~~ – ChangesEFFECTIVE CERTIFICATION SPECIFICATIONS FOR CHANGES

- (a) The Certification Specifications that the Competent Authority should use to assess the application for or the notification of a change, should be those which were effective during the date of the notification of the change by the aerodrome operator.
- (b) Notwithstanding paragraph (a) above, at any point of the process the aerodrome operator may request to use Certification Specifications that came into force after the filing of the application for, or notification of a change. In such cases, the Competent Authority should examine if it is necessary to also notify the aerodrome operator of other Certification Specifications, which also came into effect after the date of the application for, or the notification of the change by the aerodrome operator, and which are, in the opinion of the Competent Authority, directly related to those already identified as being affected by the change.
- (c) Notwithstanding paragraph (a) and (b) above, the Competent Authority may at any time, after the application or notification of a change by the aerodrome operator, decide to notify the aerodrome operator of any Certification Specifications that it deems necessary for the proposed change.

AMC2 ADR.AR.C.040(a) Changes

CHANGES REQUIRING PRIOR APPROVAL

- (a) Upon receiving an application for a proposed change that requires a prior approval, the ~~competent authority~~Competent Authority should, in due time:
 - (1) assess the proposed change in relation to the certification basis, and the applicable requirements of Part-ADR.OR, Part-ADR.OPS, as well as any other applicable requirements;
 - (2) assess if the aerodrome operator has identified all the ~~certification specifications~~applicable Certification Specifications, applicable requirements of Part-ADR.OR, Part-ADR.OPS, or other applicable requirements which are related to or affected by the change, as well as any proposal of the applicant for the demonstration of an equivalent level of safety;
 - (3) assess the actions proposed by the aerodrome operator in order to show compliance with (1) and (2) above;
 - (4) review and assess the content of proposed changes to the aerodrome manual; and

AMC/GM to Annex I – Part-AR

SUBPART C – OVERSIGHT, CERTIFICATION AND ENFORCEMENT (ADR.AR.C)

- (5) evaluate the safety assessment that has been submitted by the aerodrome operator, in accordance with AMC1-GM1 ADR.AR.C.035(~~ba~~) and verify its compliance with ADR.OR.B.~~065-040(f)~~.
- (b) The ~~competent authority~~Competent Authority should also determine, in due time:
- (1) if the proposed change is directly related to any other ~~certification specification~~Certification Specification which had been included in the certification basis. If the ~~competent authority~~Competent Authority finds such a relationship, it should include these related ~~certification specifications~~Certification Specifications amongst those to be notified to the applicant; and
 - (2) if the proposed change is such that a special condition, or an amendment to an existing special condition is required.
- (c) The ~~competent authority~~Competent Authority should document and notify, in writing, the aerodrome operator, in due time, of:
- (1) the ~~applicable certification specifications~~Certification Specifications that it has identified to be applicable in accordance with the previous paragraphs; (a) and (b);
 - ~~(2) any special conditions, or amendments to special conditions it finds necessary; and~~
 - ~~(3) any provisions for which the competent authority has accepted the applicant to demonstrate an equivalent level of safety; and~~
 - (3) any special conditions, or amendments to special conditions it finds necessary.
- (d) Any subsequent changes to the items mentioned in paragraph ~~3(c)~~, should be documented and notified to the aerodrome operator, in writing, in due time.
- ~~(e) The competent authority should verify the compliance of the aerodrome operator and, depending on the change, examine the need for prescribing any condition for the operation of the aerodrome during the change.~~
- ~~(f) When notifying the aerodrome operator in accordance with paragraph 3 or 4, the competent authority should also inform him/her of the right of appeal, as exists under the applicable national legislation.~~

~~AMC2-ADR.AR.C.040(a) – Changes~~

Competent Authority should, in due time, EFFECTIVE CERTIFICATION SPECIFICATIONS FOR CHANGES REQUIRING PRIOR APPROVAL

- ~~(a) The certification specifications that the competent authority should use and notify to the applicant should be those that were effective during the date of the application.~~
- ~~(b) Notwithstanding paragraph (a) above, if at any point of the process the aerodrome operator requests to use certification specifications which came into force after the filing of the application for a change or the notification of the certification specifications by the competent authority, then the competent authority should examine if it is necessary to also notify the aerodrome operator other certification specifications, which also came into effect after the filing of the application for the change and which are, in the opinion of the competent authority, directly related to those certification specifications that have been proposed by the aerodrome operator.~~
- ~~(c) Notwithstanding paragraph (a) and (b) above, the competent authority may at any time, after the filing of the application for a change, decide to notify the aerodrome operator any certification specifications that it deems necessary for the proposed change.~~

AMC/GM to Annex I – Part-AR

SUBPART C – OVERSIGHT, CERTIFICATION AND ENFORCEMENT (ADR.AR.C)

~~AMC1 ADR.AR.C.040(f) – Changes~~~~CHANGES NOT REQUIRING PRIOR APPROVAL~~

- ~~(a) Upon receiving a notification of a change that does not require a prior approval, the competent authority should:~~
- ~~(1) assess the change in relation to the certification basis and the applicable requirements of Part ADR.OR, Part ADR.OPS, as well as any other applicable requirements;~~
 - ~~(2) assess if the aerodrome operator has identified all the certification specifications, applicable requirements of Part ADR.OR, Part ADR.OPS, or other applicable requirements which are related to or affected by the change, as well as any cases related to demonstration of an equivalent level of safety ;~~
 - ~~(3) assess the actions proposed by the aerodrome operator in order to show compliance with (1) and (2) above;~~
 - ~~(4) review and assess the content of the changes to the aerodrome manual; and;~~
 - ~~(5) evaluate the safety assessment that has been submitted by the aerodrome operator, in accordance with AMC1 ADR.AR.C.035(b) and verify its compliance with ADR.OR.B.065.~~
- ~~(b) The competent authority should also determine:~~
- ~~(1) if the proposed change is directly related to any other certification specification which had been included in the certification basis and if such relationship has been identified by the aerodrome operator; and~~
 - ~~(2) if the proposed change is such that a special condition, or an amendment to an existing special condition is required,~~
- ~~— and document its actions.~~
- ~~(c) In case the competent authority is not satisfied with the content of the documentation submitted by the aerodrome operator, or it has identified that a special condition should be prescribed or amended, or that more evidence or clarifications are needed, it should notify the applicant in writing and as soon as possible and, if needed, request further amendments or raise a finding, or take any other action it finds necessary, as appropriate.~~
- ~~(g)(e) The competent authority should~~ verify the compliance of the aerodrome operator and, depending on the change, examine the need for prescribing any condition for the operation of the aerodrome during the change.
- ~~(h)(f) When notifying the applicant~~aerodrome operator in accordance with paragraph ~~4,(c) or (d),~~ the ~~competent authority~~Competent Authority should also inform him/her of the right of appeal, as exists under the applicable national legislation.

~~AMC2-AMC3 ADR.AR.C.040(a);(f) – Changes~~

AMC/GM to Annex I – Part-AR

SUBPART C – OVERSIGHT, CERTIFICATION AND ENFORCEMENT (ADR.AR.C)

~~EFFECTIVE CERTIFICATION SPECIFICATIONS FOR CHANGES NOT REQUIRING PRIOR APPROVAL~~

- ~~(a) The certification specifications that the competent authority should use and to assess the notification of the change, should be those which were effective during the date of the notification of the change by the aerodrome operator.~~
- ~~(b) Notwithstanding paragraph (a) above, at any point of the process the aerodrome operator may request to use certification specifications that came into force after its notification for the change. In such cases, the competent authority should examine if it is necessary to also notify the aerodrome operator other certification specifications, which also came into effect after the date of the notification of the change by the aerodrome operator, and which are, in the opinion of the competent authority, directly related to those already identified as being affected by the change.~~
- ~~(c) Notwithstanding paragraph (a) and (b) above, the competent authority may at any time, after the notification of change by the aerodrome operator, notify it any certification specifications that it deems necessary for the change.~~

~~AMC3-ADR.AR.C.040(a);(f) Changes~~

GENERAL

- (a) Changes in nominated persons: The ~~competent authority~~Competent Authority should be informed of any changes to personnel specified in ~~Part-ADR.OR.D.015 – Personnel requirements~~ that may affect the certificate or the terms of approval attached to it. When an aerodrome operator submits the name of a nominee for the nominated persons mentioned in ADR.OR.D.015, the ~~competent authority~~Competent Authority should assess his/her qualifications, and may interview the nominee, or call for additional evidence of his/her suitability before deciding upon his/her acceptability (see ~~GM1-AMC1 ADR.AR.C.035-(a)(3)~~).
- ~~(b) A documented systematic approach should be used for maintaining the information on when an amendment was received by the competent authority and when it was approved.~~
- ~~(b) The competent authority~~Competent Authority should receive from the aerodrome operator each management system documentation amendment, including amendments that do not require prior approval by the ~~competent authority~~Competent Authority. ~~A documented systematic approach should be used for maintaining the information on when an amendment was received by the Competent Authority and when it was approved.~~
- (c) Where the amendment requires the ~~competent authority's~~Competent Authority's approval, the ~~competent authority~~Competent Authority, when satisfied, should indicate its approval in writing. Where the amendment does not require prior approval, the ~~competent authority~~Competent Authority should acknowledge receipt in writing within the time limits existing under the relevant national legislation.
- (d) For changes requiring prior approval, in order to verify the aerodrome operator's compliance with the applicable requirements, the ~~competent authority~~Competent Authority should consider the need to conduct an audit of the operator, limited to the extent of the changes. If required for verification, the audit should include additional interviews and inspections carried out at the aerodrome operator's facilities.

AMC/GM to Annex I – Part-AR

SUBPART C – OVERSIGHT, CERTIFICATION AND ENFORCEMENT (ADR.AR.C)

GM1-ADR.AR.C.040(c) – ChangesAMENDMENT OF THE TERMS OF THE CERTIFICATE INCLUDED IN THE CERTIFICATE

The ~~competent authority~~ Competent Authority should amend the certificate for any change that affects the terms of ~~approval of~~ the certificate, irrespectively of their magnitude.

GM1-ADR.AR.C.040 (e)–d) ChangesCONDITIONS UNDER WHICH TO OPERATE DURING A CHANGE OF NAME OF THE AERODROME OPERATOR

- (a) ~~On receipt of the application and proof of change of name as well as the relevant parts of the aerodrome operator's documentation as required by Part ADR.OR, the competent authority should re-issue the certificate.~~
- (b) ~~A name change alone does not require the competent authority to audit the aerodrome operator, unless there is evidence that other aspects of the operator's organisation have changed.~~

~~AMC1~~ ADR.AR.C.045(a);(b) – Change of aerodrome operatorASSESSMENT OF RISKS ASSOCIATED WITH THE CHANGE OF THE OPERATOR

~~Prior to issuing the new or amending the existing certificate, the competent authority should ensure that that the new operator complies with the applicable requirements.~~

~~The competent authority should be satisfied with the arrangements between the current and the proposed operator of the aerodrome with regard to the transfer of the operations.~~

~~In addition, the competent authority should assess the safety assessment that has been submitted by the aerodrome operator, in accordance with AMC1-ADR.AR.C.035(b) and verify its compliance with ADR.OR.B.045, to ensure the safe transfer of the operations.~~

~~When deciding on the conditions or limitations under which the an aerodrome will operator can operate during the change, the competent authority should also take into account: a change should be approved by the authority but should usually be elaborated between the operator and the authority upon suggestion of the aerodrome operator.~~

- ~~— the extent and depth of the organisational changes (e.g. new nominated persons, level of changes to management positions, restructuring of the organisational structure etc); and~~
- ~~— possible changes to type of operations, or the aerodrome itself.~~

GM1-AR.C.050 – Declarations of providers of apron management services

VERIFICATION – DECLARATION

The verification made by the ~~competent authority~~ Competent Authority upon receipt of a declaration does not necessarily imply an inspection. The primary aim is to check whether what is declared complies with applicable requirements.

~~AMC1~~ GM1 ADR.AR.C.055 – Findings, observations, corrective actions, and enforcement measures

AMC/GM to Annex I – Part-AR

SUBPART C – OVERSIGHT, CERTIFICATION AND ENFORCEMENT (ADR.AR.C)

ENFORCEMENT MEASURES — FINANCIAL PENALTIES

The ~~competent authority~~ **Competent Authority** may additionally, and depending on the nature and the repetitiveness of the findings, or the level of implementation of the corrective actions, impose financial penalties as appropriate, which are effective, proportionate, and dissuasive.

~~GM1-GM2~~ ADR.AR.C.055 — Findings, observations, corrective actions, and enforcement measures**TRAINING**

For a level 1 finding, it may be necessary for the ~~competent authority~~ **Competent Authority** to ensure that further training by the aerodrome operator, or the provider of the apron management services is carried out, and audited by the ~~competent authority~~ **Competent Authority** before the activity is resumed, dependent upon the nature of the finding.

~~GM1-GM3~~ ADR.AR.C.055 — Findings, corrective actions, and enforcement measures**CATEGORIES OF FINDINGS — DOCUMENTARY EVIDENCE**

Examples of documentary evidence include, but ~~is~~ **are** not limited to:

- (a) aerodrome or equipment manuals;
- (b) contracts or other types of arrangements;
- (c) training, qualification, or medical records;
- (d) inspection records;
- (e) test or exercise results;
- (f) internal audit results;
- (g) maintenance records; and
- (h) other similar material required to be maintained by the aerodrome operator, or the provider of apron management services.

~~AMC1~~ ADR.AR.C.060 (a) — Wildlife hazard management**~~REPORTING MECHANISM~~ — REPORTING FORM**

~~(a) The competent authority should establish a mechanism for the collection and analysis of wildlife strike (or near misses) reports. It should also forward the wildlife strike reports to the ICAO to be included in the ICAO Bird Strike Information System (IBIS) database.~~

~~(b) The competent authority should ensure that the reporting forms (paper or electronic format) used by the aerodrome operators or other parties for reporting wildlife strikes, contain at least the following information:~~

~~(1) Operator involved~~

~~(2) Aircraft make/model~~

~~Engine make/model~~

~~Aircraft registration~~

~~(3) Date, (day, month year)~~

AMC/GM to Annex I – Part-AR

SUBPART C – OVERSIGHT, CERTIFICATION AND ENFORCEMENT (ADR.AR.C)

- ~~(4) Local time~~
- ~~(5) Dawn, day, dusk, night~~
- ~~(6) Aerodrome name~~
- ~~(7) Runway used~~
- ~~(8) Location if en route~~
- ~~(9) Height AGL in ft~~
- ~~(10) Speed (IAS) in kt~~
- ~~(11) Phase of flight:
 - ~~(i) Parked;~~
 - ~~(ii) Taxi;~~
 - ~~(iii) Take-off run;~~
 - ~~(iv) Climb;~~
 - ~~(v) En route;~~
 - ~~(vi) Descent;~~
 - ~~(vii) Approach;~~
 - ~~(viii) Landing roll;~~~~
- ~~(12) Part(s) of aircraft struck or damaged:
 - ~~(i) Radome;~~
 - ~~(ii) Windshield;~~
 - ~~(iii) Nose (excluding above);~~
 - ~~(iv) Engine no (1, 2, 3, 4);~~
 - ~~(v) Propeller;~~
 - ~~(vi) Wing/rotor;~~
 - ~~(vii) Fuselage;~~
 - ~~(viii) Landing gear;~~
 - ~~(ix) Tail;~~
 - ~~(x) Lights;~~
 - ~~(xi) Other (to be specified)~~~~
- ~~(13) Effect on flight:
 - ~~(i) None;~~
 - ~~(ii) Aborted take-off;~~
 - ~~(iii) Precautionary landing;~~
 - ~~(iv) Engines shut down;~~
 - ~~(v) Other (to be specified)~~~~
- ~~(14) Sky condition:~~

AMC/GM to Annex I – Part-AR

SUBPART C – OVERSIGHT, CERTIFICATION AND ENFORCEMENT (ADR.AR.C)

- ~~(i) — No cloud;~~
- ~~(ii) — Some cloud;~~
- ~~(iii) — Overcast~~
- ~~(15) — Precipitation:~~
 - ~~(i) — Fog;~~
 - ~~(ii) — Rain;~~
 - ~~(iii) — Snow~~
- ~~(16) — Bird species~~
- ~~(17) — Number of birds:~~
 - ~~(i) — Seen~~
 - ~~(A) — 1~~
 - ~~(B) — 2–10~~
 - ~~(C) — 11–100~~
 - ~~(D) — More~~
 - ~~(ii) — Struck~~
 - ~~(A) — 1~~
 - ~~(B) — 2–10~~
 - ~~(C) — 11–100~~
 - ~~(D) — more~~
- ~~(18) — Size of bird:~~
 - ~~(i) — Small~~
 - ~~(ii) — Medium~~
 - ~~(iii) — Large~~
- ~~(19) — Pilot warned of birds:~~
 - ~~(i) — (A) yes/no~~
- ~~(20) — Remarks (description of damage, injuries and other pertinent information)~~
- ~~(21) — Reporting person/organisation~~
- ~~(22) — Address and/or instructions for returning the form to the competent authority~~
- ~~(23) — Address within the Member State to which any bird remains, including feather fragments, should be sent.~~

GM1-ADR.AR.C.060(a) — Wildlife hazard management

REPORTING TO ICAO

Further guidance on reporting bird strikes to ICAO is contained in ICAO Doc 9332 — Manual on the ICAO Bird Strike Information System (IBIS).

AMC/GM to Annex I – Part-AR

SUBPART C – OVERSIGHT, CERTIFICATION AND ENFORCEMENT (ADR.AR.C)

~~AMC1-ADR.AR.C.060(b) — Wildlife hazard management~~~~MITIGATING MEASURES~~

~~Where the elimination of existing sites that may attract wildlife to the aerodrome (or its vicinity) is not possible, the competent authority should ensure that a safety assessment of the hazard posed by wildlife to aircraft operations is conducted by the aerodrome operator and that all necessary measures are identified and implemented so that the risk is reduced to a level which is as low as reasonably practicable.~~

~~AMC1-ADR.AR.C.60(b) — Wildlife hazard management~~~~PREVENTION OF INCOMPATIBLE LAND USE AROUND AERODROMES — BIRD HAZARD~~

~~The following is a non-exhaustive list of types of land uses which should in particular be prevented, eliminated or mitigated:~~

- ~~(a) — fish processing;~~
- ~~(b) — agriculture;~~
- ~~(c) — cattle feed lots;~~
- ~~(d) — garbage dumps and landfill sites;~~
- ~~(e) — factory roofs and parking lots;~~
- ~~(f) — theatres and food outlets;~~
- ~~(g) — wildlife refuges;~~
- ~~(h) — artificial and natural lakes;~~
- ~~(i) — golf or polo courses, etc.;~~
- ~~(j) — animal farms; and~~
- ~~(k) — slaughter houses.~~

~~GM1-ADR.AR.C.060(b) — Wildlife hazard management~~~~PREVENTION OF INCOMPATIBLE LAND USE AROUND AERODROMES — BIRD HAZARD~~

~~Incompatible land use around an aerodrome may influence restrictions on aircraft flights as well as negatively affect aircraft safety.~~

~~Land use around an aerodrome may influence bird strikes to aircraft. Birds may be attracted to areas near the aerodrome and in turn go to the aerodrome for food, water, resting or shelter. Some birds may also be struck outside aerodrome property, over a land use that attracts them.~~

~~The location of a proposed land use in relation to the aerodrome should be considered, because an attractive land use could create flyways over the aerodrome or through flight paths at the aerodrome.~~

~~In some cases, more than one possible use of an area may have to be considered to ensure that bird hazard will not be increased at or near the aerodrome.~~

~~Further guidance on prevention of incompatible land use around aerodromes is contained in ICAO Doc 9137 (Airport Services Manual), Part 3 — Bird Control and Reduction.~~

AMC/GM to Annex I – Part-AR

SUBPART C – OVERSIGHT, CERTIFICATION AND ENFORCEMENT (ADR.AR.C)

GM2-ADR.AR.C.060(b) — Wildlife hazard management**COORDINATION**

Depending upon the extent of the wildlife hazards in a Member State, a coordination mechanism (e.g. a national committee or equivalent) could serve as a focal point to deal with the analysis of the problem, aerodrome and aircraft operator interface and relevant research or other related activities.

The composition of such a coordination mechanism in each Member State may vary, however, it should include all the authorities associated or interested in the problem. The coordination mechanism should act as an information source in order to identify problems, mutual understanding of concerns, identifying priorities and contribute to the development of the national wildlife hazard control policy.

Such a coordination mechanism could include:

- competent authorities for civil aviation;
- competent authorities for agriculture and environment
- aerodrome operators;
- major aircraft operators;
- pilot's associations;
- aircraft and engine manufacturers.

The coordination mechanism should convene at regular intervals to keep apprised of new developments or serious issues and review the need for updating the wildlife hazard control policy.

Further guidance on coordination mechanisms with regard to wildlife management is included in ICAO Doc 9137, Part 3, Bird Control and Reduction.

GM1-ADR.AR.C.065 — Obstacles — Objects**GENERAL**

The establishment of the obstacle limitation surfaces, protection surfaces and other areas associated with an aerodrome aims at ensuring the safety and regularity of operations.

Because of their significance, it is necessary to establish a mechanism to ensure that such established surfaces and areas continuously meet the applicable requirements.

Outside the boundaries of the aerodrome the aerodrome operator has normally no legal power to protect the established surfaces and areas associated with the aerodrome.

Notwithstanding the obligations of the aerodrome operator to monitor the activities around the aerodrome and to take the actions foreseen in Part ADR.OPS, it is understood that this may not be sufficient to control/prevent the development of new obstacles, or extensions to existing ones, or to remove such obstacles that may endanger safety or make the aerodrome unusable.

Thus, it is for the Member State's competent authority to exercise its powers to prevent or correct such situations. This can be accomplished in many different ways, depending on the Member State's administrative and legal system, the coordination mechanisms and the powers vested to each competent authority.

AMC/GM to Annex I – Part-AR

SUBPART C – OVERSIGHT, CERTIFICATION AND ENFORCEMENT (ADR.AR.C)

~~In any case, the way in which this objective is to be accomplished, as well as the coordination mechanisms required to be set up, are left to the Member States.~~

~~AMC1 ADR.AR.C.065 – Obstacles (a)~~~~OUTER HORIZONTAL SURFACE~~

- ~~(a) To facilitate practicable and efficient instrument approach procedures the competent authority may establish an outer horizontal surface and define its outer limits, when an aeronautical study indicates that this is necessary;~~
- ~~(b) The outer horizontal surface should be a horizontal surface connected to the upper edge of conical surface and spreading outwards;~~
- ~~(c) The dimensions and characteristics of the outer horizontal surface should be those described in CS-ADR-DSN.H.410.~~

~~AMC2 ADR.AR.C.065(a) – Obstacles~~~~ELEVATION DATUM~~

~~The competent authority should establish the elevation datum to be used for the measurement of the height of the inner horizontal surface, in accordance with CS-ADR-DSN.H.420.~~

~~AMC1 ADR.AR.C.065(a) – Obstacles – Objects~~~~NON-INSTRUMENT RUNWAYS~~

- ~~(a) New objects or extensions of existing objects should not be permitted above an approach or transitional surface except when, in the opinion of the competent authority, the new object or extension would be shielded by an existing immovable object.~~
- ~~(b) New objects or extensions of existing objects should not be permitted above the conical surface or inner horizontal surface except when, in the opinion of the competent authority, the object would be shielded by an existing immovable object, or after aeronautical study it is determined that the object would not adversely affect the safety or significantly affect the regularity of operations of aircraft.~~
- ~~(c) Existing objects above any of the conical surface, inner horizontal surface, approach surface and transitional surfaces should as far as practicable be removed except when, in the opinion of the competent authority, the object is shielded by an existing immovable object, or after aeronautical study it is determined that the object would not adversely affect the safety or significantly affect the regularity of operations of aeroplanes.~~

~~AMC1 ADR.AR.C.065(a) – Obstacles – Objects~~~~NON-PRECISION APPROACH RUNWAYS~~

- ~~(a) New objects or extensions of existing objects should not be permitted above an approach surface within 3.000 m of the inner edge or above a transitional surface except if in the opinion of the competent authority the new object or extension would be shielded by an existing immovable object.~~

AMC/GM to Annex I – Part-AR

SUBPART C – OVERSIGHT, CERTIFICATION AND ENFORCEMENT (ADR.AR.C)

- ~~(b) New objects or extensions of existing objects should not be permitted above the approach surface beyond 3.000 m from the inner edge, the conical surface or inner horizontal surface except when, in the opinion of the competent authority, the object would be shielded by an existing immovable object, or after aeronautical study it is determined that the object would not adversely affect the safety or significantly affect the regularity of operations of aircraft.~~
- ~~(c) Existing objects above the conical surface, the inner horizontal surface, the approach surface and the transitional surfaces should as far as practicable be removed except when, in the opinion of the competent authority, the object is shielded by an existing immovable object, or after aeronautical study it is determined that the object would not adversely affect the safety or significantly affect the regularity of operations of aeroplanes.~~

AMC2-ADR.AR.C.065(a) – Obstacles – Objects

PRECISION APPROACH RUNWAYS

- ~~(a) Fixed objects should not be permitted above the inner approach surface, the inner transitional surface or the balked landing surface, except for frangible objects which because of their function must be located on the strip. Mobile objects should not be permitted above these surfaces during the use of the runway for landing.~~
- ~~(b) New objects or extensions of existing objects should not be permitted above an approach surface or a transitional surface except when, in the opinion of the competent authority, the new object or extension would be shielded by an existing immovable object.~~
- ~~(c) New objects or extensions of existing objects should not be permitted above the conical surface and the inner horizontal surface except when, in the opinion of the competent authority, an object would be shielded by an existing immovable object, or after aeronautical study it is determined that the object would not adversely affect the safety or significantly affect the regularity of operations of aircraft.~~
- ~~(d) Existing objects above an approach surface, a transitional surface, the conical surface and inner horizontal surface should as far as practicable be removed except when, in the opinion of the competent authority, an object is shielded by an existing immovable object, or after aeronautical study it is determined that the object would not adversely affect the safety or significantly affect the regularity of operations of aircraft.~~

AMC3-ADR.AR.C.065(a) – Obstacles – Objects

RUNWAYS MEANT FOR TAKE-OFF

- ~~(a) New objects or extensions of existing objects should not be permitted above a take-off climb surface except when, in the opinion of the competent authority, the new object or extension would be shielded by an existing immovable object.~~
- ~~(b) The competent authority should limit the height of new objects to preserve the characteristics of an obstacle free surface established in accordance with CS-ADR.DSN.J.485~~
- ~~(c) Existing objects that extend above a take-off climb surface should as far as practicable be removed except when, in the opinion of the competent authority, an object is shielded by an existing immovable object, or after aeronautical study it is determined that the~~

AMC/GM to Annex I – Part-AR

SUBPART C – OVERSIGHT, CERTIFICATION AND ENFORCEMENT (ADR.AR.C)

~~object would not adversely affect the safety or significantly affect the regularity of operations of aircraft.~~

~~AMC4 ADR.AR.C.065(a) — Obstacles — Objects~~~~OTHER OBJECTS~~

- ~~(a) — Objects which do not project through the approach surface but which would nevertheless adversely affect the optimum siting or performance of visual or non-visual aids should, as far as practicable, be removed.~~
- ~~(b) — (2) Anything which may, in the opinion of the competent authority after aeronautical study, endanger aeroplanes on the movement area or in the air within the limits of the inner horizontal and conical surfaces should be regarded as an obstacle and should be removed in so far as practicable.~~

~~AMC5 ADR.AR.C.065(a) — Obstacles — Objects~~~~OBSTACLE PROTECTION SURFACE FOR VISUAL APPROACH SLOPE INDICATOR SYSTEMS~~

- ~~(a) — New objects or extensions of existing objects above a protection surface should not be permitted above an obstacle protection surface except when the new object or extension would be shielded by an existing immovable object.~~
- ~~(b) — Existing objects above a protection surface:~~
- ~~(1) — Existing objects above an obstacle protection surface should be removed except when, in the opinion of the competent authority, the object is shielded by an existing immovable object, or after aeronautical study it is determined that the object would not adversely affect the safety of operations of aeroplanes;~~
 - ~~(2) — Where an aeronautical study indicates that an existing object extending above an obstacle protection surface could adversely affect the safety of operations of aeroplanes, one or more of the following measures should be taken:

 - ~~(i) — suitably raise the approach slope of the system;~~
 - ~~(ii) — reduce the azimuth spread of the system so that the object is outside the confines of the beam;~~
 - ~~(iii) — displace the axis of the system and its associated obstacle protection surface by no more than 5°;~~
 - ~~(iv) — suitably displace the threshold; and~~~~

~~where (iv) is found to be impracticable, suitably displace the system upwind of the threshold to provide an increase in threshold crossing height equal to the height of the object penetration.~~

~~AMC1 ADR AR.C.065 (b);(c) — Obstacles — Objects~~~~OBSTACLES BEYOND THE OBSTACLE LIMITATION SURFACES~~

- ~~(a) — Obstacles beyond the limits of the obstacle limitation surfaces, at least those extending to a height of 150 m or more above ground elevation, should be marked and lighted, except that the marking may be omitted when the obstacle is lighted by high intensity obstacle lights by day or medium intensity lights if it is determined by the competent authority to be sufficient.~~

AMC/GM to Annex I – Part-AR

SUBPART C – OVERSIGHT, CERTIFICATION AND ENFORCEMENT (ADR.AR.C)

- ~~(b) Overhead wires, cables, etc., crossing a river, valley or highway should be marked and their supporting towers marked and lighted if an aeronautical study indicates that the wires or cables could constitute a hazard to aircraft, except that the marking of the supporting towers may be omitted when they are lighted by high intensity obstacle lights by day.~~
- ~~(c) When it has been determined that an overhead wire, cable, etc., needs to be marked but it is not practicable to install markers on the wire, cable, etc., then high intensity obstacle lights, Type B, should be provided on their supporting towers.~~
- ~~(d) The marking and lighting of obstacles mentioned in paragraph (a), (b) and (c) above should be done in accordance with the certification specifications adopted by the Agency.~~

~~AMC1 ADR AR.C.065(b);(c) Obstacles Objects~~**~~OBSTACLES INSIDE THE OBSTACLE LIMITATION SURFACES AND OUTSIDE THE AERODROME~~**

- ~~(a) A fixed obstacle that extends above a take-off climb, approach or transitional surface within 3000 m of the inner edge of the take-off climb or approach surface should be marked and, if the runway is used at night, lighted, except that:~~
- ~~(1) such marking and lighting may be omitted when the obstacle is shielded by another fixed obstacle;~~
 - ~~(2) the marking may be omitted when the obstacle is lighted by medium intensity obstacle lights, Type A, by day and its height above the level of the surrounding ground does not exceed 150 m;~~
 - ~~(3) the marking may be omitted when the obstacle is lighted by high intensity obstacle lights by day if medium intensity lights are deemed insufficient; and~~
 - ~~(4) the lighting may be omitted where the obstacle is a lighthouse and an aeronautical study indicates the lighthouse light to be sufficient.~~
- ~~(b) A fixed object, other than an obstacle, adjacent to a take-off climb, approach or transitional surface should be marked and, if the runway is used at night, lighted, if such marking and lighting is considered necessary to ensure its avoidance, except that the marking may be omitted when:~~
- ~~(1) the object is lighted by medium intensity obstacle lights, Type A, by day and its height above the level of the surrounding ground does not exceed 150 m; or~~
 - ~~(2) the object is lighted by high intensity obstacle lights by day if medium intensity lights are deemed insufficient.~~
- ~~(c) A fixed obstacle above a horizontal surface should be marked and, if the aerodrome is used at night, lighted, except that:~~
- ~~(1) such marking and lighting may be omitted when:~~
 - ~~(i) the obstacle is shielded by another fixed obstacle; or~~
 - ~~(ii) for a circuit extensively obstructed by immovable objects or terrain, procedures have been established to ensure safe vertical clearance below prescribed flight paths; or~~
 - ~~(iii) an aeronautical study shows the obstacle not to be of operational significance;~~

AMC/GM to Annex I – Part-AR

SUBPART C – OVERSIGHT, CERTIFICATION AND ENFORCEMENT (ADR.AR.C)

- ~~(2) the marking may be omitted when the obstacle is lighted by medium-intensity obstacle lights, Type A, by day and its height above the level of the surrounding ground does not exceed 150 m;~~
- ~~(3) the marking may be omitted when the obstacle is lighted by high-intensity obstacle lights by day if medium-intensity lights are deemed insufficient; and~~
- ~~(4) the lighting may be omitted where the obstacle is a lighthouse and an aeronautical study indicates the lighthouse light to be sufficient.~~
- ~~(d) A fixed object that extends above an obstacle protection surface should be marked and, if the runway is used at night, lighted.~~

~~AMC1 ADR AR.C.065(b) – Obstacles – Objects~~**~~LIGHTING OF OBJECTS OUTSIDE THE AREA CONTROLLED BY THE AERODROME OPERATOR~~****~~(a) Use of obstacle lights~~**

- ~~(1) The presence of objects which must be lighted should be indicated by low, medium or high-intensity obstacle lights, or a combination of such lights.~~
- ~~(2) Low-intensity obstacle lights, Type A or B, should be used where the object is a less extensive one and its height above the surrounding ground is less than 45 m.~~
- ~~(3) Where the use of low-intensity obstacle lights, Type A or B would be inadequate or an early special warning is required, then medium or high-intensity obstacle lights should be used.~~
- ~~(4) Low-intensity obstacle lights, Type C, should be displayed on vehicles and other mobile objects excluding aircraft.~~
- ~~(5) Low-intensity obstacle lights, Type D, should be displayed on follow-me vehicles.~~
- ~~(6) Low-intensity obstacle lights, Type B, should be used either alone or in combination with medium-intensity obstacle lights, Type B, in accordance with subparagraph (7) below.~~
- ~~(7) Medium-intensity obstacle lights, Type A, B or C, should be used where the object is an extensive one or its height above the level of the surrounding ground is greater than 45 m medium-intensity obstacle lights, Types A and C, should be used alone, whereas medium-intensity obstacle lights, Type B, should be used either alone or in combination with low-intensity obstacle lights, Type B.~~
- ~~(8) High-intensity obstacle lights, Type A, should be used to indicate the presence of an object if its height above the level of the surrounding ground exceeds 150 m and an aeronautical study indicates such lights to be essential for the recognition of the object by day.~~
- ~~(9) High-intensity obstacle lights, Type B, should be used to indicate the presence of a tower supporting overhead wires, cables, etc., where:

 - ~~(i) an aeronautical study indicates such lights to be essential for the recognition of the presence of wires, cables, etc.; or~~
 - ~~(ii) it has not been found practicable to install markers on the wires, cables, etc.~~~~
- ~~(10) Where, in the opinion of the competent authority, the use of high-intensity obstacle lights, Type A or B, or medium-intensity obstacle lights, Type A, at night may dazzle pilots in the vicinity of an aerodrome (within approximately 10 000 m radius)~~

AMC/GM to Annex I – Part-AR

SUBPART C – OVERSIGHT, CERTIFICATION AND ENFORCEMENT (ADR.AR.C)

~~or cause significant environmental concerns at day and/or night, a dual obstacle lighting system should be provided. When a dual obstacle lighting system is provided, this system should be composed of high intensity obstacle lights, Type A or B, or medium intensity obstacle lights, Type A, as appropriate, for daytime and twilight use and medium intensity obstacle lights, Type B or C, for night time use.~~

(b) ~~Location of obstacle lights.~~

- ~~(1) One or more low, medium or high intensity obstacle lights should be located as close as practicable to the top of the object. The top lights should be so arranged as to at least indicate the points or edges of the object highest in relation to the obstacle limitation surface.~~
- ~~(2) In the case of chimney or other structure of like function, the top lights should be placed sufficiently below the top so as to minimise contamination by smoke, etc. (see Figures 1 and Figure 2).~~
- ~~(3) In the case of a tower or antenna structure indicated by high intensity obstacle lights by day with an appurtenance, such as a rod or an antenna, greater than 12 m where it is not practicable to locate a high intensity obstacle light on the top of the appurtenance, such a light should be located at the highest practicable point and, if practicable, a medium intensity obstacle light, Type A, mounted on the top.~~
- ~~(4) In the case of an extensive object or of a group of closely spaced objects, top lights should be displayed at least on the points or edges of the objects highest in relation to the obstacle limitation surface, so as to indicate the general definition and the extent of the objects. If two or more edges are of the same height, the edge nearest the landing area should be marked. Where low intensity lights are used, they should be spaced at longitudinal intervals not exceeding 45 m. Where medium intensity lights are used, they should be spaced at longitudinal intervals not exceeding 900 m.~~

~~When the obstacle limitation surface concerned is sloping and the highest point above the obstacle limitation surface is not the highest point of the object, additional obstacle lights should be placed on the highest point of the object.~~

- ~~(5) ~~Where~~ an object is indicated by medium intensity obstacle lights, Type A, and the top of the object is more than 105 m above the level of the surrounding ground or the elevation of tops of nearby buildings (when the object to be marked is surrounded by buildings), additional lights should be provided at intermediate levels if technically feasible. These additional intermediate lights should be spaced as equally as practicable, between the top lights and ground level or the level of tops of nearby buildings, as appropriate, with the spacing not exceeding 105 m (see subparagraph (7) below).~~
- ~~(6) Where an object is indicated by medium intensity obstacle lights, Type B, and the top of the object is more than 45 m above the level of the surrounding ground or the elevation of tops of nearby buildings (when the object to be marked is surrounded by buildings), additional lights should be provided at intermediate levels if technically feasible. These additional intermediate lights should be alternately low intensity obstacle lights, Type B, and medium intensity obstacle lights, Type B, and should be spaced as equally as practicable between the top lights and ground level or the level of tops of nearby buildings, as appropriate.~~
- ~~(7) Where an object is indicated by medium intensity obstacle lights, Type C, and the top of the object is more than 45 m above the level of the surrounding ground or the elevation of tops of nearby buildings (when the object to be marked is~~

AMC/GM to Annex I – Part-AR

SUBPART C – OVERSIGHT, CERTIFICATION AND ENFORCEMENT (ADR.AR.C)

~~surrounded by buildings), additional lights should be provided at intermediate levels if technically feasible. These additional intermediate lights should be spaced as equally as practicable, between the top lights and ground level or the level of tops of nearby buildings, as appropriate.~~

- ~~(8) Where high intensity obstacle lights, Type A, are used, they should be spaced at uniform intervals not exceeding 105 m between the ground level and the top light(s) specified in paragraph (b) (1) above, except that where an object to be marked is surrounded by buildings, the elevation of the tops of the buildings may be used as the equivalent of the ground level when determining the number of light levels.~~
- ~~(9) Where high intensity obstacle lights, Type B, are used, they should be located at three levels:~~
- ~~(i) at the top of the tower;~~
 - ~~(ii) at the lowest level of the catenary of the wires or cables; and~~
 - ~~(iii) at approximately midway between these two levels.~~
- ~~(10) The installation setting angles for high intensity obstacle lights, Types A and B, should be in accordance with [Table 1](#).~~
- ~~(11) The number and arrangement of low, medium or high intensity obstacle lights at each level to be marked should be such that the object is indicated from every angle in azimuth. Where a light is shielded in any direction by another part of the object, or by an adjacent object, additional lights should be provided on that object in such a way as to retain the general definition of the object to be lighted. If the shielded light does not contribute to the definition of the object to be lighted, it may be omitted.~~

~~(c) Low intensity obstacle lights — Characteristics~~

- ~~(1) Low intensity obstacle lights on fixed objects, Types A and B, should be fixed red lights.~~
- ~~(2) Low intensity obstacle lights, Types A and B, should be in accordance with the specifications in [Table 2](#).~~
- ~~(3) Low intensity obstacle lights, Type C, displayed on vehicles associated with emergency or security should be flashing blue and those displayed on other vehicles should be flashing yellow.~~
- ~~(4) Low intensity obstacle lights, Type D, displayed on follow me vehicles should be flashing yellow.~~
- ~~(5) Low intensity obstacle lights, Types C and D, should be in accordance with the specifications in [Table 2](#).~~
- ~~(6) Low intensity obstacle lights on objects with limited mobility such as aerobridges should be fixed red. The intensity of the lights should be sufficient to ensure conspicuity considering the intensity of the adjacent lights and the general levels of illumination against which they would normally be viewed.~~
- ~~(7) Low intensity obstacle lights on objects with limited mobility should as a minimum be in accordance with the specifications for low intensity obstacle lights, Type A, in [Table 2](#).~~

~~(d) Medium intensity obstacle lights — Characteristics~~

AMC/GM to Annex I – Part-AR

SUBPART C – OVERSIGHT, CERTIFICATION AND ENFORCEMENT (ADR.AR.C)

- (1) ~~Medium intensity obstacle lights, Type A, should be flashing white lights, Type B should be flashing red lights and Type C should be fixed red lights.~~
- (2) ~~Medium intensity obstacle lights, Types A, B and C, should be in accordance with the specifications in Table 2.~~
- (3) ~~Medium intensity obstacle lights, Types A and B, located on an object should flash simultaneously.~~
- (e) ~~High intensity obstacle lights – Characteristics~~
- (1) ~~High intensity obstacle lights, Types A and B, should be flashing white lights.~~
- (2) ~~High intensity obstacle lights, Types A and B, should be in accordance with the specifications in Table 2.~~
- (3) ~~High intensity obstacle lights, Type A, located on an object should flash simultaneously.~~
- (4) ~~High intensity obstacle lights, Type B, indicating the presence of a tower supporting overhead wires, cables, etc., should flash sequentially; first the middle light, second the top light and last, the bottom light. The intervals between flashes of the lights should approximate the following ratios:~~

Flash interval between	Ratio of cycle time
Middle and top light	1:13
Top and bottom light	2:13
Bottom and middle light	10:13

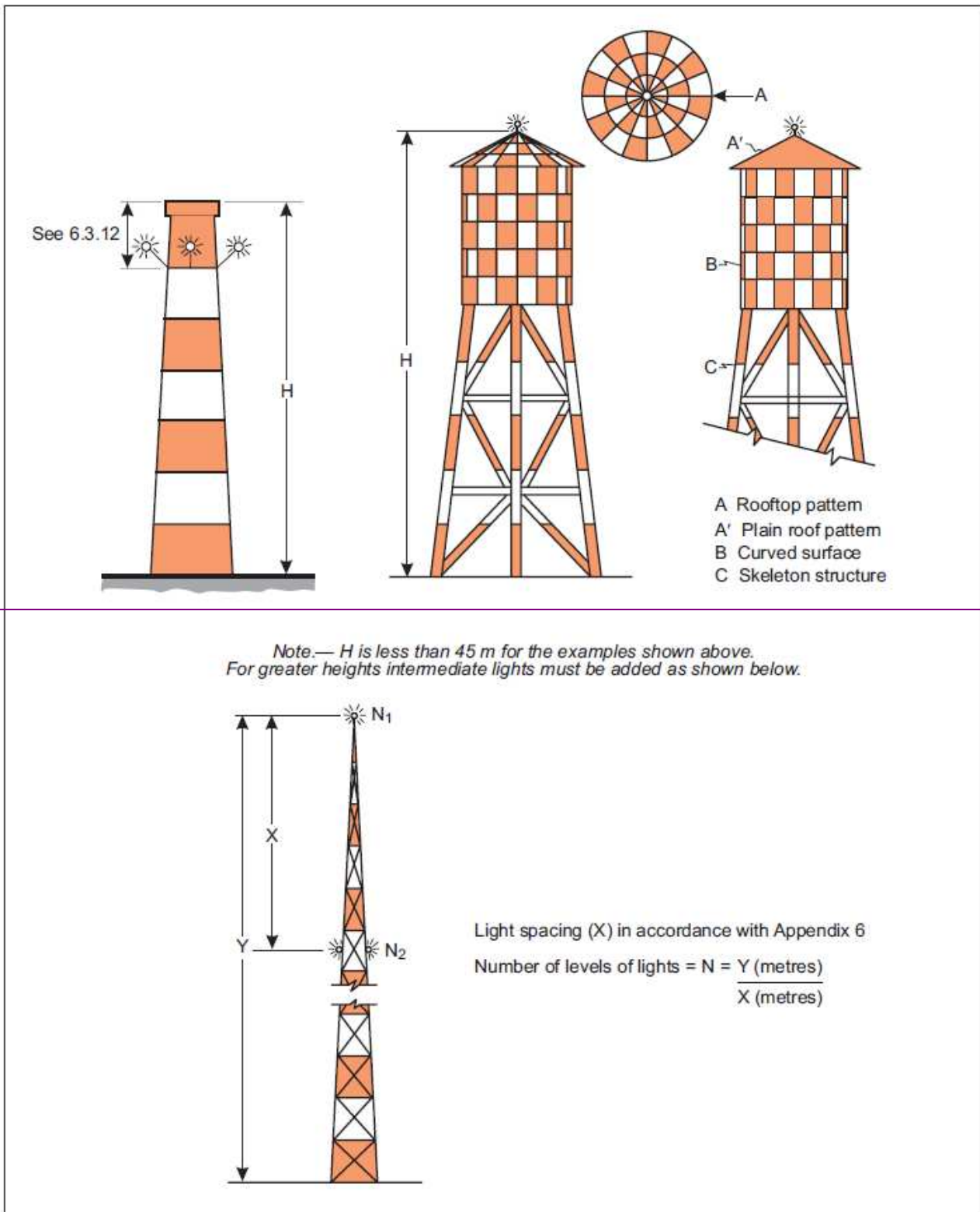

Figure 1

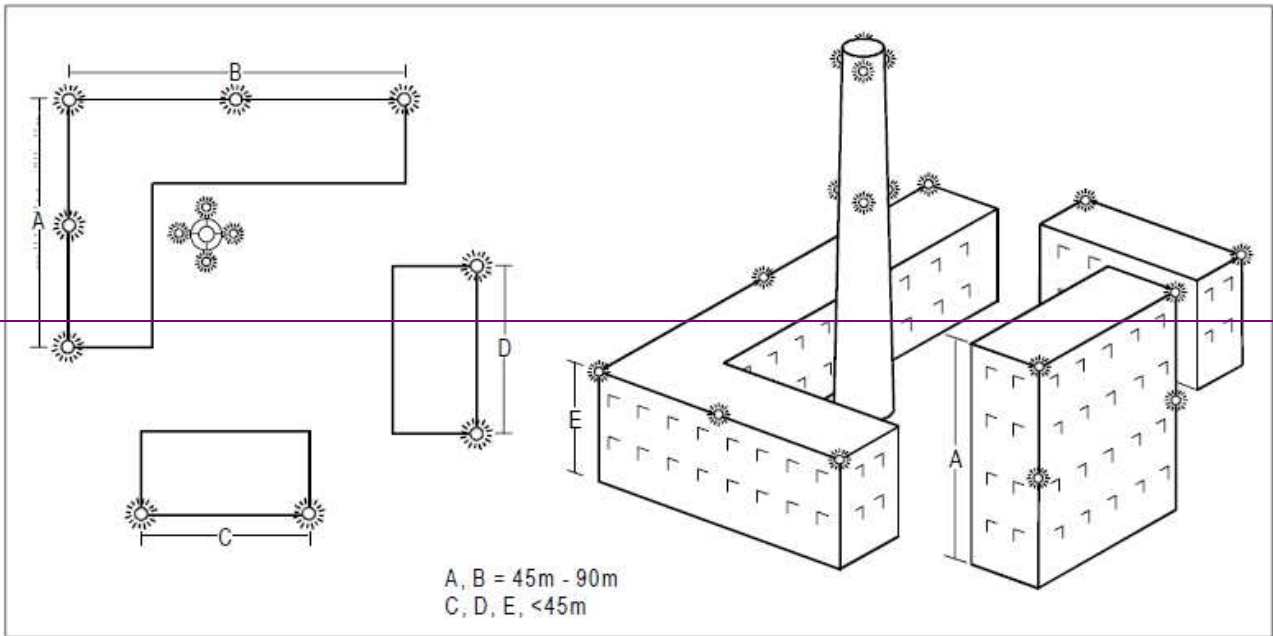

Figure 2

Height of light unit above terrain	Angle of the peak of the beam above the horizontal
Greater than 151 m AGL	0°
122 m to 151 m AGL	1°
92 m to 122 m AGL	2°
Less than 92 m AGL	3°

Table 1 Installation setting angles for high intensity obstacle lights

AMC/GM to Annex I – Part-AR

SUBPART C – OVERSIGHT, CERTIFICATION AND ENFORCEMENT (ADR.AR.C)

1	2	3	4	5	6	7	8	9	10	11	12
Light type	Colour	Signal type/flash-rate	Peak intensity (cd) at given background luminance			Vertical beam spread ^a	Intensity (c) at given elevation angles when the light unit is levelled ^d				
			Above 500cd/m ²	50-500cd/m ²	Below 50cd/m ²		-10° ^e	-1° ^f	±0° ^f	+6°	+10°
Low-intensity Type A (fixed obstacle)	Red	Fixed	N/A	10-mnm	10-mnm	10°	—	—	—	10-mnm ^g	10-mnm ^g
Low-intensity Type B (fixed obstacle)	Red	Fixed	N/A	32-mnm	32-mnm	10°	—	—	—	32-mnm ^g	32-mnm ^g
Low-intensity Type C (fixed obstacle)	Yellow/blue ^a	Flashing (60-90 fpm)	N/A	40-mnm ^b 400-max	40-mnm ^b 400-max	12° ^h	—	—	—	—	—
Low-intensity Type D (follow-me vehicle)	Yellow	Flashing (60-90 fpm)	N/A	200-mnm ^b 400-max	200-mnm ^b 400-max	12° ⁱ	—	—	—	—	—
Medium-intensity Type A	White	Flashing (20-60 fpm)	20-000 ^b ±25-%	20-000 ^b ±25-%	2-000 ^b ±25-%	3°-mnm	3°-max	50-%-mnm 75-%-max	100-%-mnm	—	—
Medium-intensity Type B	Red	Flashing (20-60 fpm)	N/A	N/A	2-000 ^b ±25-%	3°-mnm	—	50-%-mnm 75-%-max	100-%-mnm	—	—
Medium-intensity Type C	Red	Fixed	N/A	N/A	2-000 ^b ±25-%	3°-mnm	—	50-%-mnm 75-%-max	100-%-mnm	—	—
High-intensity Type A	White	Flashing (40-60 fpm)	200-000 ^b ±25-%	20-000 ^b ±25-%	2-000 ^b ±25-%	3°-7°	3°-max	50-%-mnm 75-%-max	100-%-mnm	—	—

AMC/GM to Annex I – Part-AR

SUBPART C – OVERSIGHT, CERTIFICATION AND ENFORCEMENT (ADR.AR.C)

High-intensity Type-B	White	Flashing (40–60 fpm)	100 000 ^b ±25 %	20 000 ^b ±25 %	2 000 ^b ±25 %	3°–7°	3° max	50 % min 75 % max	100 % min	—	—
-----------------------	-------	----------------------	-------------------------------	------------------------------	-----------------------------	-------	--------	----------------------	--------------	---	---

^a See 6.3.25.

^b Effective intensity as determined in accordance the Aerodrome Design Manual (Doc 9157), Part 4.

^c Beam spread is defined as the angle between two directions in a plane for which the intensity is equal to 50 % of the lower tolerance value of the intensity shown in columns 4, 5 and 6. The beam pattern is not necessarily symmetrical about the elevation angle at which the peak intensity occurs.

^d Elevation (vertical) angles are referenced to the horizontal.

^e Intensity at any specified horizontal radial as a percentage of the actual peak intensity at the same radial when operated at each of the intensities shown columns 4, 5 and 6.

^f Intensity at any specified horizontal radial as a percentage of the lower tolerance value of the intensity shown in columns 4, 5 and 6.

^g In addition to specified values, lights should have sufficient intensity to ensure conspicuity at elevation angles between ±0° and 50°.

^h Peak intensity should be located at approximately 2.5° vertical.

ⁱ Peak intensity should be located at approximately 17° vertical.

Note: fpm means flashes per minute; N/A means not applicable

Table 2 Characteristics of obstacle lights

AMC/GM to Annex I – Part-AR

SUBPART C – OVERSIGHT, CERTIFICATION AND ENFORCEMENT (ADR.AR.C)

~~AMC2-ADR-AR.C.065 (b) – Obstacles – Objects~~~~WIND TOURBINES~~

~~(a) If determined as an obstacle a wind turbine should be marked and/or lighted if it is determined by the competent authority to be an obstacle.~~

~~(b) Markings~~

~~(1) The rotor blades, nacelle and upper 2/3 of the supporting mast of wind turbines should be painted white, unless otherwise indicated by the competent authority.~~

~~(2) When the lower 1/3 of the supporting mast of a wind turbine penetrates any obstacle limitation surface, that part of the wind turbine should also be painted white, or the respective colour of the upper 2/3 of the mast.~~

~~(c) Lighting – day use~~

~~(1) When lighting is deemed necessary by the competent authority, medium intensity obstacle lights should be used. In the case of a wind farm, i.e. a group of five or more wind turbines, it should be regarded as an extensive object and the lights should be installed:~~

~~(i) to identify the perimeter of the wind farm;~~

~~(ii) respecting the maximum spacing between the lights along the perimeter, unless a dedicated risk assessment shows that a greater spacing can be used;~~

~~(iii) so that, where flashing lights are used, they flash simultaneously; and~~

~~(iv) so that, within a wind farm, any wind turbines of significantly higher elevation are also identified wherever they are located.~~

~~(2) Where the highest point of the blade on the vertical position is 150 m or less above ground level, medium intensity white lights should be used.~~

~~(3) Where the highest point of the blade on the vertical position exceeds 150 m above ground level, high intensity white lights should be prescribed by the competent authority if medium intensity lights are deemed insufficient.~~

~~(4) Obstacle lights should be installed on the nacelle in such a manner as to provide an unobstructed view for aircraft approaching them from any direction.~~

~~(i) The competent authority should prescribe additional intermediate lighting levels.~~

~~(ii) The wind turbine rotor should not shield lights on intermediate levels.~~

~~(d) Lighting – night use~~

~~(1) The competent authority should prescribe medium intensity flashing red lights instead of white lights. The competent authority may prescribe steady lights instead of flashing lights or coded red lights.~~

~~(2) The competent authority should prescribe additional intermediate lighting levels if it is deemed necessary; these lights should be low intensity fixed red lights Type A or Type B. The wind turbine rotor should not shield lights on intermediate levels.~~

~~(3) In the case of a wind farm, i.e. a group of five or more wind turbines, when lighting is deemed necessary, it should be regarded as an extensive object and lights should be installed:~~

AMC/GM to Annex I – Part-AR

SUBPART C – OVERSIGHT, CERTIFICATION AND ENFORCEMENT (ADR.AR.C)

- (i) ~~To identify the perimeter of the wind farm;~~
- (ii) ~~In accordance with the maximum between the lights along the perimeter spacing detailed in CS-ADR-DSN.Q.855 (b)(4), unless a dedicated assessment shows that a greater spacing can be used;~~
- (iii) ~~To ensure redundancy in case of perimeter lighting failure;~~
- (iv) ~~So that where flashing lights are used, they flash simultaneously;~~
- (v) ~~So that, within a wind farm, any wind turbines of significantly higher elevation are also identified wherever they are located;~~
- (4) ~~The light intensity should be reduced so as to prevent dazzling effects, significant environmental concerns or if the competent authority concludes that reduction guarantees a satisfactory level of obstacle visibility.~~
- (a) ~~The competent authority may prescribe red light instead of white light and steady lighting instead of flashing lighting.~~

~~AMC1-ADR.AR.C.070(a) — Confusing, misleading and hazardous lights~~~~LIGHTS THAT MAY ENDANGER THE SAFETY OF AIRCRAFT~~

- (a) ~~The use of non aeronautical ground lights near an aerodrome, which might endanger the safety of aircraft, should not be permitted by the competent authority; such non aeronautical ground lights should be extinguished, screened or otherwise modified, so as to eliminate the source of hazard.~~
- (b) ~~The competent authority should have as appropriate arrangements with other competent authorities, in order to achieve (a) above.~~

~~AMC2-ADR.AR.C.070(a) — Confusing, misleading and hazardous lights~~~~LIGHTS WHICH MAY CAUSE CONFUSION~~

- (a) ~~The competent authority should ensure that: a non aeronautical ground light which, by reason of its intensity, configuration or colour, might prevent, or cause confusion in, the clear interpretation of aeronautical ground lights should not be permitted. Such lights should be extinguished, screened or otherwise modified so as to eliminate such a possibility. In particular, attention should be directed to a non aeronautical ground light visible from the air within the areas described below:~~
 - (1) ~~Instrument runway — code number 4:~~
 - ~~— within the areas before the threshold and beyond the end of the runway extending at least 4,500 m in length from the threshold and runway end and 750 m either side of the extended runway centre line in width.~~
 - (2) ~~Instrument runway code number 2 or 3:~~
 - ~~— as in (1), except that the length should be at least 3,000 m.~~
 - (3) ~~Instrument runway code number 1, and non instrument runway:~~
 - ~~— within the approach area.~~
- (a) ~~Arrangements with other competent authorities are in place, as appropriate, to achieve (a) above.~~

AMC/GM to Annex I – Part-AR

SUBPART C – OVERSIGHT, CERTIFICATION AND ENFORCEMENT (ADR.AR.C)

~~AMC1-ADR.AR.C.070 (b) – Confusing, misleading and hazardous lights~~~~LASER EMISSIONS WHICH MAY ENDANGER SAFETY~~

~~(a) The competent authority should ensure that the following protected zones are established and implemented around an aerodrome and that appropriate arrangements with other competent authorities are in place, in order to protect the safety of aircraft against the hazardous effects of laser emitters:~~

~~(1) a laser beam free flight zone (LFFZ);~~

~~(2) a laser beam critical flight zone (LCFZ);~~

~~(3) a laser beam sensitive flight zone (LSFZ).~~

~~(b) The competent authority should determine the exposure levels and distances that adequately protect flight operations.~~

~~GM1-ADR.AR.C.070(b) – Confusing, misleading and hazardous lights~~~~LASER EMISSIONS~~

~~When implementing AMC1-ADR.AR.C.070 (b), figures 1, 2 and 3 may be used to determine the exposure levels and distances that adequately protect flight operations.~~

~~The restrictions on the use of laser beams in the three protected flight zones, LFFZ, LCFZ and LSFZ, refer to visible laser beams only. Laser emitters operated by the state authorities or the aerodrome operator in a manner compatible with flight safety are excluded. In all navigable airspace, the irradiance level of any laser beam, visible or invisible, is expected to be less than or equal to the maximum permissible exposure (MPE) unless such emission has been notified to the competent authority and permission obtained.~~

~~The protected flight zones are established in order to mitigate the risk of operating laser emitters in the vicinity of aerodromes. However, the prevention of the illegal use of laser emitters may require additional measures to be taken.~~

~~Further guidance on how to protect flight operations from the hazardous effects of laser emitters is contained in the Manual on Laser Emitters and Flight Safety (ICAO Doc 9815).~~

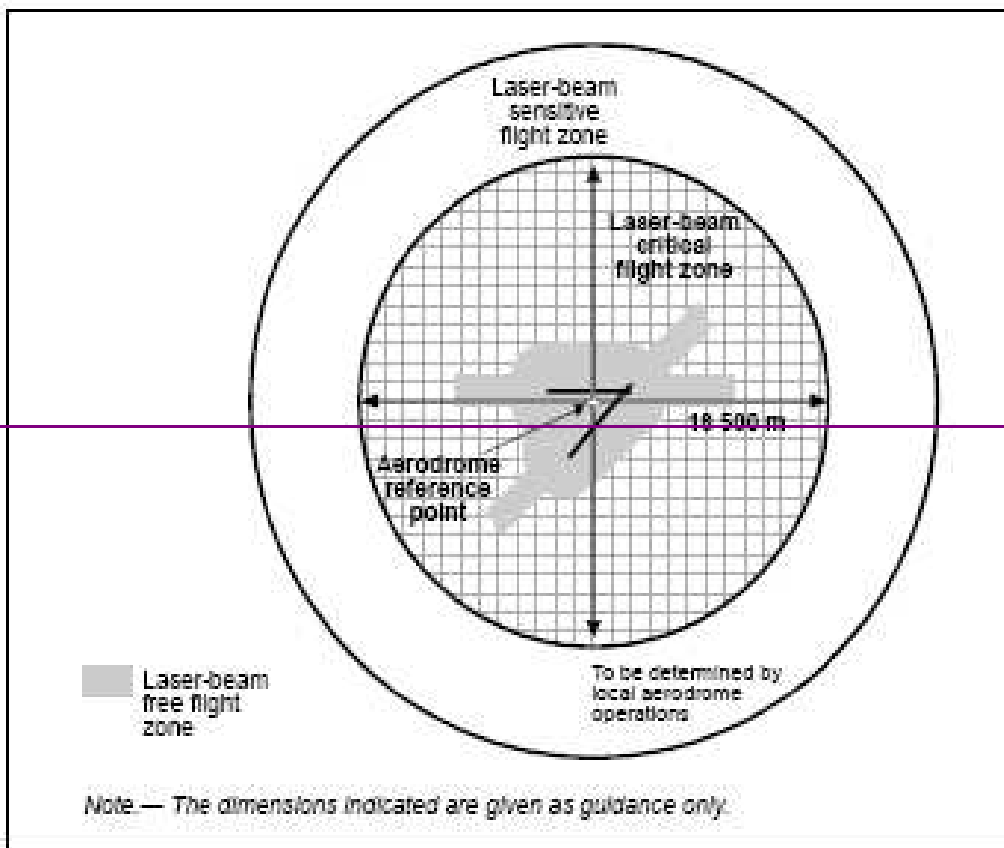

Figure 1

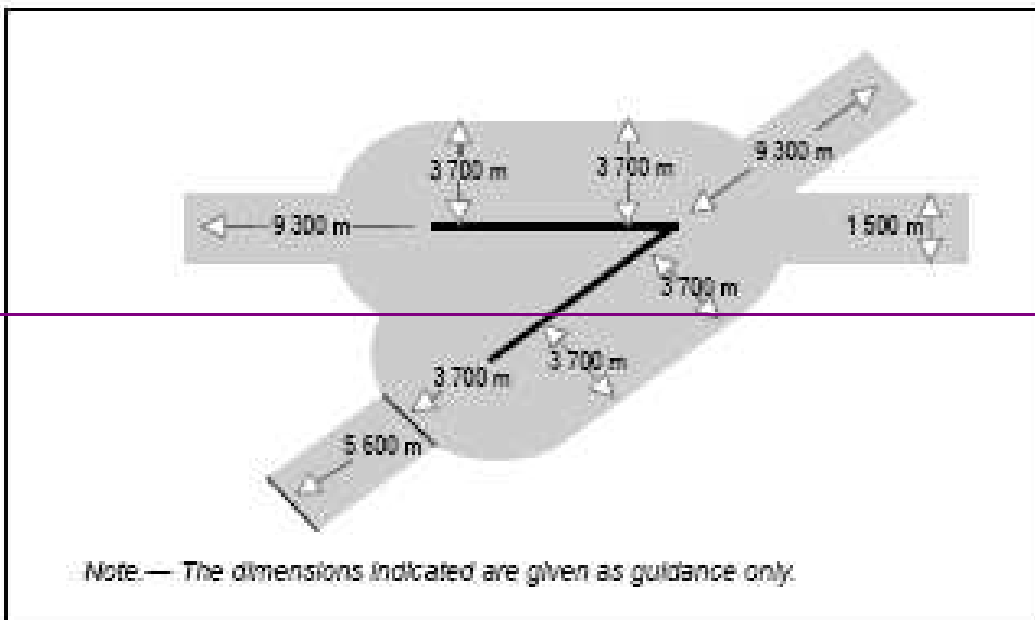

Figure 2

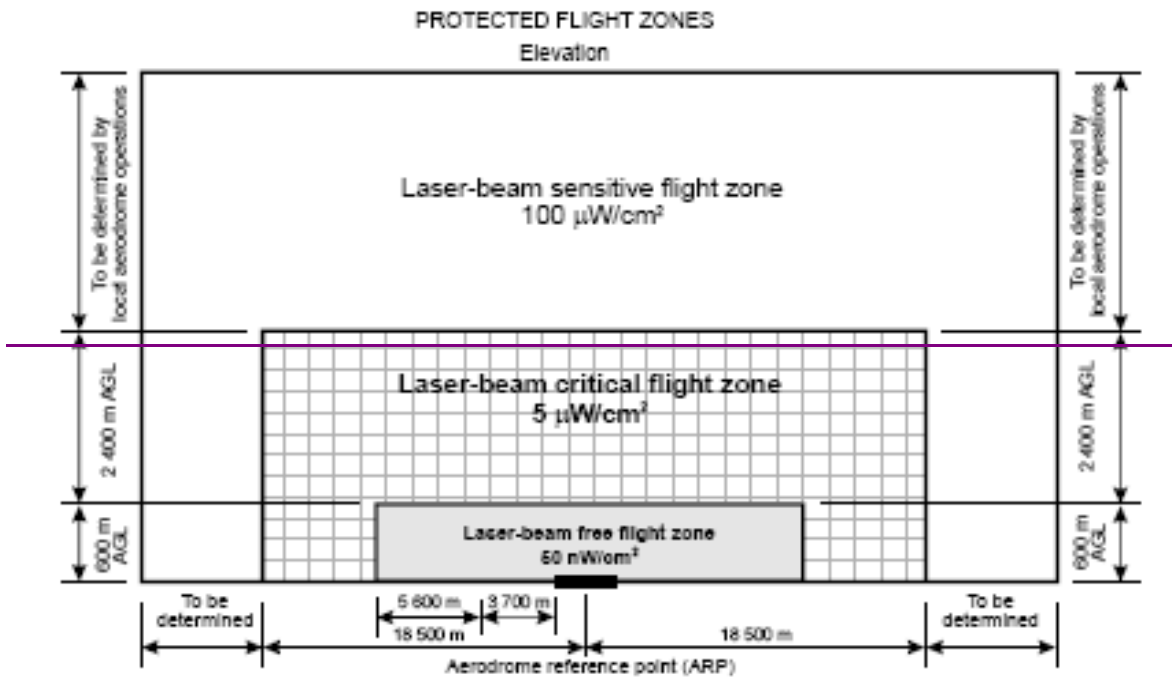

Figure 3

GM2-ADR.AR.C.070—Confusing, misleading and hazardous lights

USE OF LASER EMITTERS FOR WILDLIFE HAZARD CONTROL ACTIVITIES

The use of laser emitters by aerodrome operators for wildlife hazard management activities may be allowed by the competent authority, if it is done in a manner that does not endanger safety.

CRD to NPA 2011-20 (B.II)

09/12/201126

AMC/GM to Annex I – Part-AR

Nov 2012

SUBPART C – OVERSIGHT, CERTIFICATION AND ENFORCEMENT (ADR.AR.C)

AMC/GM to ANNEX I – Part Organisation Requirements – Aerodrome Operators
(Part-ADR.OR)

SUBPART A – GENERAL REQUIREMENTS (ADR.OR.A)

GM1-AMC1 ADR.OR.A.005 — Scope015 Means of compliance

AERODROMES OPEN TO PUBLIC USE

~~An aerodrome whose use may or requires prior notice to be given to its operator does not qualify that aerodrome as not being open to public use.~~

~~Similarly, the fact that certain aircraft types or operations may not be or are not allowed at a given aerodrome, or that they are allowed under certain conditions or an approval of the competent authority does not mean that such an aerodrome is not open to public use.~~

~~To the extent that an aerodrome is used for commercial air transport, by aircraft operators who comply with conditions or limitations such as those described above, an aerodrome should be considered to be under the scope of the Basic Regulation and its Implementing Rules, provided that the other criteria contained in article 4(3a) of the Basic Regulation are also met.~~

DEMONSTRATION OF COMPLIANCE

In order to demonstrate that the Implementing Rules are met, a safety assessment should be completed and documented. The result of this risk assessment should demonstrate that an equivalent level of safety to that established by the Acceptable Means of Compliance (AMC) adopted by the Agency is reached.

SUBPART B – CERTIFICATION (ADR.OR.B)

AMC1-ADR.OR.B.015(a) – Application for a certificate

APPLICATION

The application should be made in writing, and be signed by the applicant, using a standardised form ~~adopted~~established by the ~~competent authority~~Competent Authority.

AMC1-ADR.OR.B.015(b)(1);(2);(3)~~);(4)~~ Application for a certificate

INFORMATION TO BE PROVIDED TO THE COMPETENT AUTHORITY

(a) The applicant should

(1) provide its telephone, and fax number, and e-mail address for communication with the ~~competent authority~~Competent Authority; ~~In addition, the applicant should~~

~~(1)~~(2) indicate to the authority the names of its employees whom the ~~competent authority~~Competent Authority would contact in order to address any issues that might arise during the evaluation of the application, and the certification process.

(b) The applicant should provide the ~~competent authority~~Competent Authority with the following:

~~(a)~~ information ~~with regard to:~~

(1) about the location of the aerodrome: the exact location of the aerodrome should be depicted on a map of a suitable scale acceptable to the Competent Authority;

(2) information about the type of operations at the aerodrome, including:

(i) operations during the day and/or night, and type of approaches;

(ii) landing, and/or take-off operations on each runway;

~~(ii)~~(iii) the aircraft types to be served at the aerodrome, and the aircraft type to be used for the design of the aerodrome; and

~~(iii)~~(iv) any limitations to the operation of the aerodrome.

(3) the drawing(s) showing the design of the aerodrome, which should:

(i) be in a suitable scale, acceptable to the Competent Authority;

~~(ii)~~ ~~meet the applicable aeronautical data requirements; and~~

~~(iii)~~(ii) be in an electronic format, if this is acceptable to the ~~competent authority~~Competent Authority.

(iii) ~~the design of the aerodrome should include~~contain all the necessary information, including:

(A) runway(s) orientation;

(B) the dimensions of the aerodrome's physical characteristics;

(C) the visual and non-visual aids;

(D) the obstacle limitation surfaces, and any other surfaces applicable, ~~showing any obstacles or objects that could endanger safety present;~~ and

SUBPART B – CERTIFICATION (ADR.OR.B)

(E) the aerodrome facilities, installations, and fixed equipment and their location.

(5) Description, height, and location of obstacles or objects that could endanger safety, in accordance with the applicable aeronautical data requirements (see ADR.OPS.A.005 and AMC1 ADR.OPS.A.005).

(6) A meteorological study of the area, including temperature, visibility, and ceiling and wind conditions, including wind conditions occurring with poor visibility and/or low cloud base at the aerodrome, and their frequency, as well as the accompanying wind direction and speed.

~~(b)~~(c) The applicant should propose to the ~~competent authority~~Competent Authority the certification specifications which are applicable to the proposed aerodrome. These should consist of a list of:

- (1) the certification specifications that are matching the design and the operation of the aerodrome; ~~and~~
- (2) ~~the certification specifications~~if relevant, the Certification Specifications for which the applicant proposes to show compliance in a different manner and demonstrate ~~and an~~ equivalent level of safety. Such a proposal has to be acceptable to the ~~competent authority~~Competent Authority. In such cases, the applicant should also propose the method that will be used to demonstrate compliance and achieve an equivalent level of safety ~~(ELoS)~~, and submit all the necessary documentation to support the proposal; ~~;~~
- (3) ~~Any~~if relevant, any other proposal for which the applicant assumes that the ~~certification specifications~~Certification Specifications issued by the Agency are inadequate or inappropriate.

(d) The applicant should provide the ~~competent authority~~Competent Authority documentation to demonstrate how he/she will comply with the applicable requirements of the Basic Regulation, Part-ADR.OR, and Part-ADR.OPS, and any other applicable requirements that are matching the aerodrome design and its operation.

~~The applicant should indicate the requirements for which an exemption or derogation is proposed, if applicable. In such cases, the applicant should also submit to the competent authority the necessary justification and documentation for the exemption or the derogation, in accordance with article 14 of the Basic Regulation.~~

~~Additionally, the applicant should indicate to the competent authority the means of compliance that intends to use, in order to show compliance with the applicable requirements. Such information should also include the intended use of alternative means of compliance with the applicable requirements, and all relevant documentation in accordance with article ADR.OR.A.015.~~

~~AMC1 ADR.OR.B.015(b)(3) — Application for a certificate~~

~~PROVISION OF~~

AMC1 ADR.OR.B.015(b)(4) Application for a certificate

EVIDENCE OF ARRANGEMENTS WITH THIRD PARTIES

The applicant should provide all necessary evidence for arrangements with third parties that provide, or intend to provide services, or undertake activities at the aerodrome, whose activities may have an impact on safety. ~~Such evidence should cover all organisations with~~

~~which the aerodrome operator needs to have arrangements, including those mentioned in ADR.OR.C.005.~~

AMC1-~~ADR.OR.B.015(b)(4)–5~~ Application for a certificate

ADEQUACY OF RESOURCES

(a) General

The applicant should provide all necessary information needed in order to demonstrate to the ~~competent authority~~Competent Authority that its proposed organisation and management, ~~including its financial capability,~~ are suitable, and properly matched to the scale and scope of the operation.

~~In demonstrating such compliance the applicant should, amongst others, take into account in its analysis the following:~~

- ~~(1) — the size and complexity of the aerodrome;~~
~~— the type of traffic;~~
~~— the type of operations;~~
- ~~(2) — the level and the density of the traffic;~~
- ~~(3) — the operating hours of the aerodrome;~~
~~— the amount of full time equivalent (FTEs) necessary for each activity;~~
- ~~(4) — human factors principles;~~
- ~~(5) — labour legislation; and~~
~~— the degree of subcontracting;~~

~~In case of subcontracting, the applicant should provide to the authority with all necessary evidence of such contracts.~~

The aerodrome operator should have the ability to discharge its responsibilities with regard to safety. The accountable manager should have access, as well as the authorisation, to the necessary resources to ensure that operations are carried out in accordance with the regulations applicable requirements. The resources ~~should also include, but are not limited to,~~ personnel, tools and equipment, as well as financial resources.

AMC2-~~ADR.OR.B.015(b)(4)–~~Application for a certificate

~~ARRANGEMENTS WITH PARTIES NECESSARY FOR THE OPERATION OF THE AERODROME~~

(b) Arrangements with other parties

The applicant should indicate those services that are going to be provided directly by himself/herself and those that will be provided by ~~contacted~~contracted third parties with regard to the adequacy of the resources.

The applicant should also provide ~~the necessary~~ evidence ~~needed, that is contractual~~ of arrangements, if third parties are going to be involved in the provision of services. In addition, the applicant should provide any relevant information needed, or requested by the Competent Authority, regarding such third parties.

AMC1-GM1 ADR.OR.B.015(b)(5) Application for a certificate

ADEQUACY OF RESOURCES

(a) General

In demonstrating to the Competent Authority the suitability of its organisation and management, the applicant should, amongst others, take into account in his/her analysis the following:

- (6) the size and complexity of the aerodrome;
- (7) the type of traffic;
- (8) the type of operations;
- (7)(9) the level and the density of the traffic;
- (8)(10) the operating hours of the aerodrome;
- (11) the amount of full-time equivalents (FTEs) necessary for each activity;
- (9)(12) human factors principles;
- (10)(13) labour legislation; and
- (14) the degree of subcontracting.

(b) Adequacy of financial resources

The financial resources required are linked to the overall objective for the safe operation and maintenance of the aerodrome, including the aerodrome operator's capability to implement the corrective actions needed, in a timely manner. Information that may be provided to the Competent Authority includes audited accounts of the previous financial year, business plans etc.

AMC1- ADR.OR.B.015(b)(6) Application for a certificate

RELATIONSHIP OF THE APPLICANT WITH THE AERODROME OWNER

The applicant should demonstrate to the ~~competent authority~~ Competent Authority, in accordance with the applicable national legislation that he/she is duly authorised to undertake all activities necessary under the provisions of the Basic Regulation, and its Implementing Rules ~~is~~, and any other applicable national or ~~Community~~ European Union rule.

The applicant should also provide the ~~competent authority~~ Competent Authority with all information necessary, under the applicable national legislation, to demonstrate to the ~~competent authority~~ Competent Authority his/–her relationship ~~between~~ with the aerodrome owner, and/or the owner of the land to be used for the aerodrome development.

Such documentation should include, but is not limited to, contracts, lease agreements, authorisations between the persons involved, etc.

AMC1-ADR.OR.B.015(b)(8)—7) Application for a certificate

INFORMATION TO BE PROVIDED FOR MANAGEMENT PERSONNEL

The applicant should provide information regarding the qualifications, and experience of the accountable manager, and the other nominated persons required.

AMC1 ADR.OR.B.015(b)(9) Application for a certificate

AERODROME MANUAL

The aerodrome manual and its amendments may be submitted to the ~~competent authority~~Competent Authority in electronic format, if this is acceptable to the ~~competent authority~~Competent Authority. If the aerodrome manual is submitted in electronic format, the format should be such that allows the Competent Authority to review, store, and reproduce it.

GM1-ADR.OR.B.015 — Application for a certificate

INITIAL INTEREST

Prior to submitting an application for a certificate to the ~~competent authority~~Competent Authority, an applicant should arrange for a meeting with the ~~competent authority~~Competent Authority.

The applicant should also make arrangements for its key personnel to be present during this meeting.

During this meeting, the applicant should present to the authority its plans with regard to the aerodrome.

~~The applicant should also make arrangements so that its key personnel are present during this meeting.~~

During the meeting, the applicant may be:

- (a) provided by the ~~competent authority~~Competent Authority with general information about the applicable requirements for the aerodrome;
- (b) ~~It may also be~~ provided with copies of the applicable requirements, and a description of the procedures that are followed during the certification process; and
- (c) ~~The applicant may also be~~ informed by the ~~competent authority~~Competent Authority about possible approvals, permits, or clearances that may be needed to be obtained from other competent authorities of the Member State.

GM2-GM1 ADR.OR.B.015(b)(1);(2);(3)—) Application for a certificate

AERODROME BOUNDARIES

The map ~~attached to submitted with~~ the application ~~for an aerodrome certificate~~ should ~~show~~indicate the boundary of the ~~aerodrome area subject to certification~~. It should ~~therefore~~ include, at least, runways, taxiways, aprons, associated strips ~~and, in most cases, the area,~~ runway end safety areas, stopways, clearways, aerodrome visual aids, fixed aerodrome equipment, other aerodrome operational areas, areas adjacent to the ~~terminal building~~. The

~~defined area will movement area, etc, while maintenance areas may be the subject of aerodrome oversight by the competent authority once the certificate is awarded excluded if acceptable to the Competent Authority.~~

The above aerodrome boundary should not be confused with the boundaries established for other purposes, such as fences, the land ownership boundaries used by local planning authorities, or those used to designate security restricted zones.

AMC1 ADR.OR.B.025(a)(1) Demonstration of compliance

USE OF THIRD PARTIES TO DEMONSTRATE COMPLIANCE

~~While the aerodrome owner may own land adjacent performing the necessary actions, inspections, tests, safety assessments, or near to the aerodrome, they may exclude those areas, including those that may be set aside for the movement of aircraft but over which exercises necessary to demonstrate compliance, the aerodrome operator has no direct control, e.g. maintenance areas may also use contracted third parties.~~

~~Any developments and activities outside~~In any case, the responsibility remains with the aerodrome operator.

AMC1 ADR.OR.B.025(a)(1) Demonstration of compliance

FLIGHT PROCEDURES

~~Evidence that the flight procedures of the aerodrome boundary but adjacent to it should be subject to the aerodrome operator's safety management system.~~

~~GM1 ADR.OR.B.025~~ have been approved, as required by the applicable requirements, is considered to be an Acceptable Means of Compliance.

~~The obligations of the aerodrome operator prescribed under~~**GM1 ADR.OR.B.025** ~~are not limited to the initial certification.~~

~~On the contrary, the aerodrome operator is meant to comply with ADR.OR.B.025 at any stage and in all cases where~~ **(a)(3) Demonstration of compliance** ~~has to be demonstrated in accordance with the provisions of this Regulation e.g. a change of the infrastructure, a change in the operation, implementation of a safety directive etc.~~

MODEL FORM OF DECLARATION OF COMPLIANCE — AERODROME OPERATORS

Declaration of compliance

of aerodrome operator

in accordance with Commission Regulation (EC) No/..... on aerodrome design and operation

Aerodrome name — Location indicator:

Aerodrome operator

Name:

<u>Place in which the operator is established or residing:</u>
<u>Name and contact details of the accountable manager:</u>
<u>Statements</u>
<u>The certification basis is complied with, and the aerodrome, as well as its obstacle limitation and protection surfaces, and other areas associated with the aerodrome, have no features or characteristics making it unsafe for operation.</u>
<u>All personnel are qualified, competent, and trained in accordance with the applicable requirements.</u>
<u>The management system documentation, including the aerodrome manual, comply with the applicable requirements set out in Part-ADR.OR and Part-ADR.OPS.</u>
<u>The operation and maintenance of the aerodrome will be carried out in accordance with the requirements of Regulation (EC) No 216/2008 and its Implementing Rules, the terms of the certificate, and the procedures and instructions specified in the aerodrome manual.</u>
<u>The aerodrome operator confirms that the information disclosed in this declaration is correct.</u>
<u>Date, name and signature of the accountable manager</u>

AMC1-ADR.OR.B.040(a) – Changes

CHANGES REQUIRING PRIOR APPROVAL

The aerodrome operator should ensure that prior to initiating any change to the aerodrome or its operation, which requires prior approval, an application is submitted to the ~~competent authority~~Competent Authority. The applicant should provide documentation containing a description of the proposed change, in which the following are identified:

- (a) the parts of the aerodrome and the aerodrome manual~~7~~ which are affected by the change, including relevant appropriate detailed design drawings~~;~~
- (b) the certification specifications with which the proposed change has been designed to comply with~~7~~, including the certification specifications for which the applicant proposes to show compliance in a different manner in order to ~~accomplish and demonstrate an~~

equivalent level of safety (for such cases see AMC1-~~ADR.OR.B.015(b)(1);-(2);~~
~~f);(3);(4)~~, paragraph ~~3(b(c)(2))~~);

- (c) the requirements of Part-ADR.OR and Part-ADR.OPS, and any other applicable requirements that have to be complied with as a result of the proposed change, including the way in which compliance is intended to be demonstrated; and
- (d) the safety assessment required under ADR.OR.B.~~065-040(f)~~.

Examples

GM1 ADR.OR.B.040 (a);(b)

CHANGES REQUIRING PRIOR APPROVAL

The following is a list of such changes include items requiring prior approval by the Competent Authority, as specified in the applicable Implementing Rules.

- (a) Use of alternative means of compliance as required by ADR.OR.A.015 Means of Compliance.
- (b) Changes to the notification procedure as required by ADR.OR.B.015 Application for a certificate.
- (c) Changes to the certification basis, or the terms of the certificate of the aerodrome, as required by ADR.OR.B.040 Changes.
- (a)(d) Changes to aerodrome equipment including, but are not limited to, the following: ILS, MLS, VOR, DME, NDB, Surface Movement Radar, RFFS vehicles, Continuous Friction Measurement Equipment, secondary power supply etc. as required by ADR.OR.B.040 Changes.
 - (1) Significant changes to any of the physical characteristics of a runway; such as:
 - (b)(e) new runway(s): a development resulting in elements of the construction of a 'new' runway (e.g. new construction, or the change of an existing grass surface to a paved surface); operator's management system as required by ADR.OR.D.005(b) Management.
 - (i) runway extension or shortening resulting in an amendment to declared distances;
 - (ii) threshold relocation (Instrument Status): a development involving relocation of the instrument runway threshold, or relocation of a non-instrument runway threshold in preparation for instrument status;
 - (iii) changes to runway designation.
 - (2) changes of the aerodrome visual aids or other changes to the aerodrome, when such changes are associated with a change (upgrade or downgrade) of the intended operations (e.g. to accommodate low visibility operations and/or night operations);
- (f) Changes to the training programme as required by ADR.OR.D.017 Training and proficiency check programmes.
- (g) Changes to the proficiency check programme as required by ADR.OR.D.017 Training and proficiency check programmes
- (h) Changes to the level of protection of rescue and firefighting services as required by ADR.OPS.B.010 Rescue and firefighting services.
- (i) Changes to low visibility procedures as required by ADR.OPS.B.045 Low Visibility Operations.
- (e)(j) Major constructions at the aerodrome operating minima; as required by ADR.OPS.B.070 Aerodrome works safety.
 - (3) change that affects the obstacle limitation surfaces associated Operation of aircraft with approved type of approaches;
 - (4) change in the level higher code letter as required by ADR.OPS.B.090 Use of the rescue and fire-fighting services;

- ~~(5) changes in the organisational structure of the organisation, including responsibilities, and accountabilities;~~
- ~~(6) changes related to fuel provision.~~

~~AMC1-ADR.OR.B.040(c) – Changes~~

~~CHANGES NOT REQUIRING PRIOR APPROVAL~~

~~(d)(k) The aerodrome operator should ensure that for every change that a prior approval is not required, the procedure approved by the competent authority for managing such changes, is implemented. The documentation to be provided to the competent authority in such cases is described in paragraph 1 of ADR.OR.B.040(d).by higher code letter aircraft.~~

~~(l) Changes to the maintenance programme as required by ADR.OPS.C.005 General.~~

~~(e)(m) Major maintenance activities as required by ADR.OPS.C.005 General.~~

~~(a) **GM1** The Certification Specifications that should be used for a change not requiring a prior approval are those which were in effect on the date of the notification of the change to the competent authority.~~

~~(b) Notwithstanding paragraph (b), the aerodrome operator may decide to use certification specifications that became effective after the date of the notification of the change to the competent authority.~~

~~GM1-ADR.OR.B.040 – Changes~~

~~MAINTENANCE ACTIVITIES~~

~~Routine maintenance activities, such as re-painting of the markings, changing of light-bulbs etc, affect certain elements of the certification basis and therefore qualify as changes, and therefore should be treated as such. The procedure to be followed depends on whether such a change requires or not a prior approval of the competent authority.~~

~~AMC1-ADR.OR.B.045(a) – Assessment of changes~~

~~SAFETY ASSESSEMENT FOR A CHANGE~~

~~ADR.OR.B.040(f) Changes~~

~~ASSESSMENT OF CHANGES~~

~~(a) Safety assessment for a change~~

A safety assessment for a change should include:

- (1) identification of the scope of the change;
- (2) identification of hazards;
- (3) determination of the safety criteria applicable to the change;
- (4) risk analysis in relation to the harmful effects or improvements in safety related to the change;

SUBPART B – CERTIFICATION (ADR.OR.B)

- (5) risk evaluation and, if required, risk mitigation for the change to meet the applicable safety criteria;
- (6) verification that the change conforms to the scope that was subject to safety assessment, and meets the safety criteria, before the change is put into operation; and
- (7) the specification of the monitoring requirements necessary to ensure that the aerodrome and its operation will continue to meet the safety criteria after the change has taken place.

~~AMC1-ADR.OR.B.045(b) – Assessment of changes~~

~~SCOPE OF THE SAFETY ASSESSMENT~~

~~(b) Scope of the safety assessment~~

The scope of the safety assessment should include the following elements and their interaction:

- (1) the aerodrome, its operation, management, and human elements being changed;
- (2) interfaces and interactions between the elements being changed and the remainder of the system;
- (3) interfaces and interactions between the elements being changed and the environment in which it is intended to operate; and
- (4) the full lifecycle of the change from definition to operations.

~~AMC1-ADR.OR.B.045(d) – Assessment of changes~~

~~SAFETY CRITERIA~~

~~(c) Safety criteria~~

The safety criteria used should be defined in accordance with the procedures for the management of change contained in the aerodrome manual.

The safety criteria used should, depending on the availability of data, be specified with reference to explicit quantitative acceptable safety risk levels, recognised standards, and/or codes of practice, the safety performance of the existing system, or a similar system elsewhere may be used.

~~AMC1-GM1 ADR.OR.B.055 – Change060 Declaration of aerodrome operator~~

~~REQUIRED DOCUMENTATION~~

- ~~(a) Apart from the safety assessment, the current and future aerodrome operator should provide detailed arrangements and plans with regard to the transfer providers of operations.~~

~~The new aerodrome operator should also provide all the evidence and documentation required for a newly certified aerodrome in accordance with the applicable requirements, identifying also any change to the apron management system of the aerodrome, including but not limited to organisational structure, appointed and nominated persons, number of personnel,~~

~~arrangements with other organisations etc, or any other evidence the competent authority finds is needed.~~ **services**

~~(b) However, documentation related to the design, facilities, equipment and operation of the aerodrome need not be submitted, unless changes to these elements are to take place as well.~~

MODEL FORM OF DECLARATION OF COMPLIANCE – PROVIDERS OF APRON MANAGEMENT SERVICES

Declaration of compliance
of provider of Apron Management Services

In accordance with Commission Regulation (EC) No XXX/2013 laying down requirements and procedures related to aerodromes pursuant to Regulation (EC) No 216/ 2008 of the European Parliament and of the Council

Provider of apron management services

Company name and address:

Name and contact details of the accountable manager:

Starting date of operation:

Aerodrome(s) at which the apron management services are provided:

Applicable requirements set out in Part-ADR.OPS on the provision of apron management services are documented and reflected in the aerodrome manual.

Attached to this declaration is a list of alternative means of compliance with references to the AMCs they replace, in accordance with ADR.OR.A.015(c).

The services are provided in accordance with the content of the relevant aerodrome manual.

Personnel of the apron management services provider have received the necessary initial training, and receive recurrent training to ensure continuing competence.

(If applicable) The operator has implemented and demonstrated conformance to an officially recognised industry standard.

Reference of the standard: _____ Certification body:

Date of the last conformance audit:

Any change in the operation that affects the information disclosed in this declaration will be notified to the Competent Authority.

I hereby confirm that the information disclosed in this declaration is correct.

Date and signature of the accountable manager

AMC1-ADR.OR.B.065 – Termination of operation

TERMINATION OF OPERATION

~~The aerodrome~~In case of intended termination of the operation of the aerodrome, the aerodrome operator should notify, in writing, the ~~competent authority~~Competent Authority and the Aeronautical Information Service provider, ~~in case of intended termination of the operation of the aerodrome. In such cases, the.~~The notification should be done in such time in advance, so as to allow for the timely publication of the changes, and their notification by the Aeronautical Information Regulation And Control (AIRAC) system in accordance with the related timeframe.

Upon the termination of the operation, the aerodrome operator should apply closed runway markings, as well as any other measure the authority has found appropriate.

SUBPART C – ADDITIONAL OPERATOR RESPONSIBILITIES (ADR.OR.C)

AMC1-ADR.OR.C.005(e) Operator(c) Aerodrome operator Responsibilities

PUBLICATION OF INFORMATION TO THE AERONAUTICAL INFORMATION PUBLICATION

A description of cases involving exemptions, derogations, cases of equivalent level of safety, special conditions, including limitations with regard to the use of the aerodrome, should be published in the aeronautical information publication, Aeronautical Information Publication (AIP), after coordination with the competent authority/Competent Authority.

~~GM1-ADR.OR.C.010—Use of the aerodrome by large aircraft~~

~~ELEMENTS TO BE ASSESSED~~

~~When assessing the possibility of operation of aircraft whose code letter is higher than the code letter of the aerodrome reference code, the aerodrome operator should, amongst other issues, assess the impact of the characteristics of the aircraft on the aerodrome, its facilities, equipment and its operation, and vice versa.~~

~~Aircraft characteristics to be assessed include, but are not limited to:~~

- ~~(a) fuselage length;~~
- ~~(b) fuselage width;~~
- ~~(c) fuselage height;~~
- ~~(d) tail height;~~
- ~~(e) wingspan;~~
- ~~(f) wing tip vertical clearance;~~
- ~~(g) cockpit view;~~
- ~~(h) distance from the pilot's eye position to the nose landing gear and to the main landing gear;~~
- ~~(i) landing gear design;~~
- ~~(j) outer main gear wheel span;~~
- ~~(k) wheelbase;~~
- ~~(l) main gear steering system;~~
- ~~(m) maximum aircraft mass;~~
- ~~(n) landing gear geometry, tire pressure and ACN values;~~
- ~~(o) engine data;~~
- ~~(p) Maximum passenger and fuel carrying capacities;~~
- ~~(q) flight performance;~~
- ~~(r)(m) technology evolution.~~

~~Further guidance on this issue is contained in ICAO Circular 305-AN/177 and ICAO Circular 301-AN/174.~~

SUBPART C – ADDITIONAL OPERATOR RESPONSIBILITIES (ADR.OR.C)

ADR-AMC1 OR.C.030 — Occurrence reporting 020(b) Findings

GENERAL

The corrective action plan defined by the operator should address the effects of the non-compliance, as well as its root cause.

GM1 OR.C.020 Findings

GENERAL

- (a) Preventive action is the action to eliminate the cause of a potential non-compliance or other undesirable potential situation.
- (b) Corrective action is the action to eliminate or mitigate the root cause(s), and prevent recurrence of an existing detected non-compliance, or other undesirable condition or situation. Proper determination of the root cause is crucial for defining effective corrective actions to prevent recurrence.
- (c) Correction is the action to eliminate a detected non-compliance.

SUBPART C – ADDITIONAL OPERATOR RESPONSIBILITIES (ADR.OR.C)

AMC1 ADR.OR.C.030 Occurrence reporting

GENERAL

The aerodrome operator and the provider of provider of apron management services should establish procedures to be used for reporting to the ~~competent authority~~Competent Authority and any other organisation required. ~~The procedures should which~~ include:

- (a) description of the applicable requirements for reporting;
- (b) description of the reporting mechanism, including reporting forms, means, and deadlines;
- (c) personnel responsible for reporting; and
- (d) description of mechanism and personnel responsibilities for identifying root causes, and the actions that may be needed to be taken to prevent similar occurrences in the future, as appropriate.

AMC1- ADR.OR.C.040 — Prevention of fire

The aerodrome operator should develop procedures and assign responsibilities for the control of smoking or activities that involve the use of fire hazard.

In addition, these procedures should address the adoption and use of mitigating measures when necessary activities (e.g. maintenance, etc.) which might involve fire hazard need to be authorised.

Such authorised activities may nevernot include smoking ~~since it is prohibited within the movement area, other operational areas of the aerodrome, or areas of the aerodrome where fuel or other flammable material are stored.~~

SUBPART D – MANAGEMENT (ADR.OR.D)

AMC1-~~ADR.OR.-D.005(a)(2)–b)(1)~~ Management system

~~QUALITY MANAGEMENT SYSTEM~~

~~(a) A quality management system supporting the origination, production, storage, handling, processing, transfer and distribution of aeronautical data and aeronautical information should:~~

- ~~(1) — define the quality policy in such a way as to meet the needs of different users as closely as possible;~~
- ~~— set up a quality assurance programme that contains procedures designed to verify that all operations are being conducted in accordance with applicable requirements, standards and procedures, including the relevant requirements of this Regulation;~~
- ~~(2) — provide evidence of the functioning of the quality system by means of manuals and monitoring documents;~~
- ~~(3) — appoint management representatives to monitor compliance with, and adequacy of, procedures to ensure safe and efficient operational practices; and~~
- ~~— perform reviews of the quality system in place and take remedial actions, as appropriate.~~

~~An EN ISO 9001 certificate, issued by an appropriately accredited organisation, is considered as a sufficient means of compliance.~~

~~AMC2-ADR.OR.-D.005(a)(2)–Management~~

~~SECURITY MANAGEMENT FOR AERONAUTICAL DATA AND AERONAUTICAL INFORMATION PROVISION ACTIVITIES~~

~~(b) The security management objectives should be:~~

- ~~(1) to ensure the security of aeronautical data aeronautical information received, produced or otherwise employed so that it is protected from interference and access to it is restricted only to those authorised; and~~
 - ~~(i) to ensure that the security management measures meet appropriate national or international requirements for critical infrastructure and business continuity, and international standards for security management, including: ~~ISO/IEC 17799:2005 – Information technology – Security techniques – Code of practice for information security management ISO 28000:2007: – Specification for security management systems for the supply chain.~~~~

~~(c) Regarding the ISO standards, the relevant certificates issued by an appropriately accredited organisation, are considered as a sufficient means of compliance.~~

~~AMC1-ADR.OR.D.005(b)(1)~~ Management

SAFETY MANAGEMENT SYSTEM

The safety management system of an aerodrome operator should ~~include~~encompass safety by establishing an organisational structure for the management of safety proportionate and appropriate to the size of the ~~organisation~~aerodrome operator, and the nature and type of operations. ~~Clearly defined lines of responsibilities, authorisations~~The organisational structure should include a Safety Review Board, and ~~accountabilities within the organisation should be identified. Depending~~depending on ~~the~~its organisational complexity and structure, ~~this should include a Safety Services Office to assist the work of the safety manager, in accordance with paragraph (a) and a Safety Review Board or similar.~~(b) below:

(a) Safety Services Office

- (1) The safety manager (see ADR.OR.D.015 and AMC1.ADR.OR.D.015(c)) should be responsible for the operation of the Safety Services Office which should be independent and neutral in terms of the processes and decisions made regarding the delivery of services by the line managers of operational units~~;~~.
- (2) The function of the Safety Services Office should be to:
 - (i) manage and oversee the hazard identification system;
 - (ii) monitor safety performance of operational units directly involved in aerodrome operations;
 - (iii) advise senior management on safety management matters; and
 - (iv) assist line managers with safety management matters~~;~~.
- (3) Operators of multiple aerodromes should either establish a central Safety Services Office and appropriate safety departments/functions at all aerodromes or separate Safety Services Office at each aerodrome. Arrangements should be made to ensure continuous flow of information and adequate coordination.

(b) Safety Review Board

- (1) The Safety Review Board should be a high level committee that considers matters of strategic safety in support of the accountable manager's safety accountability~~;~~.
- (2) The board should be chaired by the accountable manager~~,~~ and be composed of heads of functional areas~~;~~.
- (3) The Safety Review Board should monitor:
 - (i) safety performance against the safety policy and objectives;
 - (ii) that any safety action is taken in a timely manner; and
 - (iii) the effectiveness of the organisation's safety management system~~.~~
- (4) The Safety Review Board should ensure that appropriate resources are allocated to achieve the established safety performance.
- ~~(5)~~ Operators of multiple aerodromesThe safety manager or any other relevant person may attend, as appropriate, Safety Review Board meetings. He/she may communicate to the accountable manager all information, as necessary, to allow decision making based on safety data.
- ~~(5)~~(6) Operators of multiple aerodromes should either establish a central Safety Review Board, or separate Safety Review Boards for each aerodrome or group of aerodromes. In the case of central or group Safety Review Groups, they should

ensure that all aerodromes are represented in the Safety Review Board, at the appropriate management level. Arrangements should be made to ensure continuous flow of information and adequate coordination.

~~GM1 ADR.OR. D.005(b)(1)~~ — Management

~~SAFETY SERVICES OFFICE~~

~~The role of the Safety Services Office may be exercised by the nominated person(s) for the safety management function, considering the size of the organisation, the type and complexity of operations.~~

In less complex aerodrome organisations/operations, the aerodrome operator should nominate a person who fulfils the role of safety manager, and who is responsible for coordinating the safety management system (see ADR.OR.D.015 and AMC1 ADR.OR.D.015(c)).

GM1 ADR.OR. D.005(b)(1) Management system

SAFETY REVIEW BOARD — SAFETY ACTION GROUP

(a) Safety Review Board

Depending on the size of the organisation, the type and complexity of operations, the responsibilities of the Safety Review Board may be included in other high level committees of the organisation.

~~SAFETY ACTION GROUP~~

(b) Safety action group

- (1) A Safety Action Group may be established as a standing group, or as an ad hoc group to assist or act on behalf of the Safety Review Board.
- (2) More than one safety action group may be established depending on the scope of the task and specific expertise required.
- (3) A ~~safety action group~~ Safety Action Group should report to, and take strategic direction from the ~~safety review board~~ Safety Review Board, and should be comprised of managers, supervisors, and personnel from operational areas.
- (4) The Safety Action Group should:
 - (i) monitor operational safety;
 - (ii) resolve identified risks;
 - (iii) assess the impact on safety of operational services;
 - (iv) ensure that safety actions are implemented within agreed timescales; and
 - (v) review the effectiveness of previous safety recommendations and promotions.

~~further guidance on this issue is contained in ICAO Doc 9859~~

(a) GM2

~~AMC1~~ ADR.OR. D.005(b)(1) Management system

SAFETY SERVICES OFFICE — SAFETY REVIEW BOARD — SAFETY ACTION GROUP

Different titles may also be used for the Safety Services Office, the Safety Review Board, and the Safety Actions Group.

AMC1 ADR.OR. D.005(b)(2) – Management system

SAFETY POLICY

- (a) The safety policy should:
- (1) be endorsed by the accountable manager;
 - (2) clearly identify safety as the highest organisational priority over commercial, operational, environmental, or social pressures;
 - (3) reflect organisational commitments regarding safety and its proactive and systematic management;
 - (4) be communicated, with visible endorsement, throughout the organisation;
 - (5) include safety reporting principles; and
 - (6) be periodically reviewed to ensure it remains relevant and appropriate to the organisation.
- (b) The safety policy should:
- (1) include a commitment:
 - (i) to improve towards the highest safety standards;
 - (ii) to comply with all applicable legal requirements, meet all applicable standards, and consider best practices;
 - (iii) to provide appropriate resources;
 - (iv) to enforce safety as one primary responsibility of all managers and staff;
 - (2) include the safety reporting procedures;
 - (3) with reference to a just culture, clearly indicate which types of operational behaviours are unacceptable, and include the conditions under which disciplinary action would not apply; and
 - (4) be periodically reviewed to ensure it remains relevant and appropriate.
- (c) Senior management should:
- (1) continually promote the safety policy to all personnel, and demonstrate their commitment to it;
 - (2) provide necessary human and financial resources for its implementation; and
 - (3) establish safety objectives and performance standards.

GM1-ADR.OR. D.005(b)(2) – Management system

SAFETY POLICY

(a) Safety policy – General

The safety policy is the means whereby the aerodrome operator states its intention to maintain and, where practicable, improve safety levels in all its activities, and to minimise its contribution to the risk of an aircraft accident as far as ~~is~~ reasonably practicable. The safety

policy should state that the purpose of safety reporting, and internal investigations is to improve safety, not to apportion blame to individuals.

Further guidance on this issue is contained in ICAO Doc 9859.

(b) Safety policy – Just culture

~~GM2-ADR.OR.D.005(b)(2) – Management~~

~~EXAMPLE SAFETY POLICY~~

~~SAFETY POLICY STATEMENT~~

~~Safety is one of our core business functions. We are committed to developing, implementing, maintaining and constantly improving strategies and processes to ensure that all our aviation activities take place under a balanced allocation of organisational resources, aimed at achieving the highest level of safety performance and meeting European Union and international standards, while delivering our services.~~

~~All levels of management and all employees are accountable for the delivery of this highest level of safety performance, starting with the [chief executive officer (CEO)/managing director/or as appropriate to the organisation].~~

~~Our commitment is to:~~

- ~~— Support the management of safety through the provision of all appropriate resources, that will result in an organisational culture that fosters safe practices, encourages effective safety reporting and communication, and actively manages safety with the same attention to results as the attention to the results of the other management systems of the organisation;~~
- ~~— Enforce the management of safety as a primary responsibility of all managers and employees;~~
- ~~— Clearly define for all staff, managers and employees alike, their accountabilities and responsibilities for the delivery of the organisation's safety performance and the performance of our safety management system;~~
- ~~— Establish and operate hazard identification and risk management processes, including a hazard reporting system, in order to eliminate or mitigate the safety risks of the consequences of hazards resulting from our operations or activities to a point which is as low as reasonably practicable (ALARP);~~
- ~~— Ensure that no action will be taken against any employee who discloses a safety concern through the hazard reporting system, unless such disclosure indicates, beyond any reasonable doubt, an illegal act, gross negligence, or a deliberate or wilful disregard of regulations or procedures;~~
- ~~— Comply with and, wherever possible, exceed, legislative and regulatory requirements and standards;~~
- ~~— Ensure that sufficient skilled and trained human resources are available to implement safety strategies and processes;~~
- ~~— Ensure that all staff are provided with adequate and appropriate aviation safety information and training, are competent in safety matters, and are allocated only tasks commensurate with their skills;~~
- ~~— Establish and measure our safety performance against realistic safety performance indicators and safety performance targets;~~

- ~~— Continually improve our safety performance through management processes that ensure that relevant safety action is taken and is effective; and~~
- ~~— Ensure externally supplied systems and services to support our operations are delivered meeting our safety performance standards.~~

(Signed) _____

CEO/Managing Director/or as appropriate

Further guidance on the issue of safety policy is contained in ICAO Doc 9859.

~~GM3-ADR.OR.D.005(b)(2) — Management~~

~~SAFETY POLICY — JUST CULTURE~~

The safety policy should actively encourage effective safety reporting and, by defining the line between acceptable performance (often unintended errors) and unacceptable performance (such as negligence, recklessness, violations, or sabotage), provide fair protection to reporters. A safety or just culture may not, however, preclude the 'criminalisation of error', which is legally, ethically, and morally within the sovereign rights of any Member State, provided Community/European Union law and established international agreements are observed. A judicial investigation, and consequences of some form, may be expected following an accident or serious incident especially if a system-failure resulted in lives lost or property damaged, even if no negligence or ill-intent existed. A potential issue could, therefore, exist if voluntary hazard reports, which relate to latent deficiencies of a system or its performance, are treated in the same way as those concerning accident, and serious incident investigations. The intent of protecting hazard reports should not challenge the legitimacy of a judicial investigation, or demand undue immunity. However, legal argument does usually take precedence over any technical or safety-related argument.

Further guidance on safety policy and just culture is contained in see ICAO Doc 9859.

~~AMC1- ADR.OR.D.005(b)(3) _ Management system~~

HAZARD IDENTIFICATION PROCESS

- (a) ~~Reactive, proactive~~Hazard identification should be based on a combination of reactive, proactive, and predictive methods of safety data collection. Reactive, proactive, and predictive schemes for hazard identification should be the formal means of collecting, recording, analysing, acting on, and generating feedback about hazards and the associated risks that affect the safety of the operational activities.
- (b) All reporting systems, including confidential reporting schemes, should include an effective feedback process.

~~GM1- ADR.OR.D.005(b)(3) — _ Management system~~

HAZARD IDENTIFICATION

(a) Hazard identification — General

- (1) Hazard identification may include the following factors and processes:
 - (i) design factors, including equipment and task design;
 - (ii) procedures and operating practices, including their documentation and checklists, and their validation under actual operating conditions;

- (iii) communications, including means, terminology, and language;
 - (iv) personnel factors, such as company policies for recruitment, training, remuneration, and allocation of resources;
 - (v) organisational factors, such as the compatibility of production and safety goals, the allocation of resources, operating pressures, and the corporate safety culture;
 - (vi) work environment factors, such as ambient noise and vibration, temperature, lighting, and the availability of protective equipment and clothing;
 - (vii) regulatory oversight factors, including the applicability and enforceability of regulations, the certification of equipment, personnel, and procedures, and the adequacy of oversight;
 - (viii) defences, including such factors as the provision of adequate detection and warning systems, the error tolerance of equipment, and the resilience of equipment to errors and failures; and
 - (ix) human performance, restricted to medical conditions and physical limitations.
- (2) Hazard identification may use internal and external sources.
- (i) Internal sources:
 - (A) voluntary occurrence reporting schemes;
 - (B) safety surveys;
 - (C) safety audits;
 - (D) normal operations;
 - (E) monitoring schemes;
 - (F) trend analysis;
 - (G) feedback from training; and
 - (H) investigation and follow-up of incidents
 - (ii) External sources:
 - (A) accident reports;
 - (B) state mandatory occurrence reporting system; and
 - (C) state voluntary reporting system.
- (3) The methods used for hazard identification depends on the resources and constraints of each particular aerodrome operator, and on the size and the complexity of the operations. Nevertheless, hazard identification, regardless of implementation, complexity and size, is part of the aerodrome operator's safety documentation. Under mature safety management practices, hazard identification is a continuous, ongoing daily activity. It is an integral part of the aerodrome operator's processes. There are three specific conditions under which special attention to hazard identification should be paid. These three conditions should trigger more in depth and far reaching hazard identification activities and include:
- (i) any time that the aerodrome operator experiences an unexplained increase in safety related events or regulatory infractions;
 - (ii) any time major operational changes are foreseen, including changes to key personnel or other major equipment or systems; and

- (iii) before and during periods of significant organisational change, including rapid growth of contraction, corporate mergers, acquisitions, or downsizing.
- (4) Hazard identification may use the following tools and techniques:
- (i) brainstorming, which is an unbounded but facilitated discussion with a group of experts;
 - (ii) Hazard and Operability (HAZOP) Study, which is a systematic and structured approach using parameter and deviation guidewords. This technique relies on a very detailed system description being available for study and usually involves breaking down the system into well-defined subsystems and functional or process flows between subsystems. Each element of the system is then subject to discussion within a multidisciplinary group of experts, against the various combinations of the guidewords and deviations;
 - (iii) checklists, which are lists of known hazards or hazard causes that have been derived from past experience. The past experience could be previous risk assessments, or similar systems, or operations, or from actual incidents that have occurred in the past. The technique involves the systematic use of an appropriate checklist and the consideration of each item on the checklist for possible applicability to a particular system. Checklists should always be validated for applicability prior to use;
 - (iv) Failure Modes and Effects Analysis (FMEA), which is a 'bottom up' technique, used to consider ways in which the basic components of a system can fail to perform their design intent. The technique relies on a detailed system description and considers the ways in which each sub-component of the system could fail to meet its design intent, and what the consequences could be for the overall system. For each sub-component of a system the FMEA should consider:
 - (A) all the potential ways that the component could fail;
 - (B) the effects that each of these failures would have on the system behaviour;
 - (C) the possible causes of the various failure modes; and
 - (D) how the failures might be mitigated within the system or its environment.

The system level at which the analysis is applied can vary and is determined by the level of detail of the system description used to support the analysis. Depending on the nature and complexity of the system, the analysis could be undertaken by an individual system expert, or by a team of system experts acting in group sessions.
 - (v) the Structured What-If Technique (SWIFT) is a simple and effective alternative technique to HAZOP and involves a multidisciplinary team of experts. It is a facilitated brainstorming group activity, but is typically carried out on a higher level system description, having fewer sub-elements, than for HAZOP and with a reduced set of prompts.
- (5) Identified hazards are registered in a hazard log. The nature and format of such log may vary from a simple list of hazards to a more sophisticated relational database linking hazards to mitigations, responsibilities, and actions. The following information may be included in the hazard log:
- (i) unique hazard reference number against each hazard;

- (ii) hazard description;
- (iii) indication of the potential causes of the hazard;
- (iv) qualitative assessment of the possible outcomes and severities of consequences arising from the hazard;
- (v) qualitative assessment of the risk associated with the possible consequences of the hazard;
- (vi) description of the risk controls for the hazard; and
- (vii) indication of responsibilities in relation to the management of risk controls.

(6) Additionally, the following information may also be included in the log:

- (i) a quantitative assessment of the risk associated with the possible consequences of the hazard;
- (ii) record of actual incidents or events related to the hazard, or its causes;
- (iii) risks tolerability statement;
- (iv) statement of formal system monitoring requirements;
- (v) indication of how the hazard was identified;
- (vi) hazard owner;
- (vii) assumptions; and
- (viii) third party stakeholders.

(b) ~~Further guidance on hazard~~ Hazard identification — Indicators

(1) Reactive (lagging) indicators:

Metrics that measure events that have already occurred and that impact on safety performance.

is contained As reactive indicators only reflect system failures, their use can only result in ICAO Doc 9859 determining a reactive response. Although they do measure failure to control hazards, they do not normally reveal why the system failed, or if there are any latent hazards.

(2) Proactive (Leading) indicators:

~~GM2-ADR.OR.D.005(b)(3)~~ **Management**

HAZARD IDENTIFICATION

~~(a)~~ **PROACTIVE (LEADING) INDICATORS:**

Metrics that measure inputs to the safety system (either within an organisation, a sector, or across the total aviation system) to manage and improve safety performance.

Proactive indicators indicate good safety practices being introduced, developed, and adapted, which by their inclusion seek to establish a proactive safety environment that engenders continuous improvement. They provide useful information when accident and incident rates are low to identify latent hazards and potential threats, and consequent opportunities for improvement.

There should always be a connection between a proactive indicator and the unwanted outcomes (or reactive indicators) that their monitoring is intended to warn against.

~~(b) REACTIVE (LAGGING) INDICATORS:~~

~~— Metrics that measure events that have already occurred and that impact on safety performance.~~

~~— As reactive indicators only reflect system failures their use can only result in determining a reactive response. Although they do measure failure to control hazards, they do not normally reveal why the system failed or if there are any latent hazards.~~

~~(c) PREDICTIVE INDICATORS (PRECURSOR EVENTS):~~

~~(3) Predictive indicators (precursor events):~~

These metrics can be considered as ~~Indicators~~indicators that do not manifest themselves in accidents or serious incidents. They indicate less severe system failures or 'near misses', which when combined with other events may lead to an accident or serious incident.

In a large organisation, a mature safety management system ~~should~~ include all of these measures. Risk management effort, however, should be targeted at ~~Leading Indicators~~leading indicators and ~~Precursor Events~~precursor events.

~~Further guidance on hazard identification is contained in ICAO Doc 9859.~~

AMC1-ADR.OR.D.005(b)(4) — Management system

SAFETY RISK ASSESSMENT AND MITIGATION

- (a) A formal safety risk assessment and mitigation process should be developed and maintained that ensures analysis (in terms of probability and severity of occurrence), assessment (in terms of tolerability), and control (in terms of mitigation) of risks.
- (b) The levels of management who have the authority to make decisions regarding the tolerability of safety risks, in accordance with (a) above, should be specified in the aerodrome manual.

~~Further guidance on safety risk assessment and mitigation is contained in ICAO Doc 9859.~~

GM1-ADR.OR.D.005(b)(4) — Management system

SAFETY RISK ASSESSMENT AND MITIGATION

Safety risk assessment is the analysis of the safety risks of the consequences of the hazards that have been determined. Safety risk analysis breaks down the risks into two components — the probability of occurrence of a damaging event or condition, and the severity of the event or condition, should it occur. Safety risk decision making and acceptance should be specified through a risk tolerability matrix. The definition and final construction of the matrix should be left to the operator to design, be documented in the aerodrome manual, and be subject to an approval by the ~~competent authority~~Competent Authority.

~~**AMC1** Further guidance on safety risk assessment is contained in ICAO Doc 9859.~~

~~GM1~~ **ADR.OR.D.005-(b)(4)–5) Management**

~~SAFETY ASSESSMENT FOR RISK MANAGEMENT~~

~~(a) Applicability and Scope~~

- ~~(1) For the application of safety risk management to aerodromes, this guidance material presents the general methodology to conduct safety assessments on an aerodrome. It provides guidance to defining the scope of the safety concern, Hazard Identification, safety risk assessment as well as through appropriate reasoning to evaluate the suitability of proposed solutions and the need for alternate measures, operational procedures or operating restrictions for the specific operations concerned.~~
- ~~(2) The methodology provides a basic safety assessment process and lists some key aspects that should be taken into consideration when conducting, reviewing or evaluating a safety assessment. The purpose of this guide is to:
 - ~~(i) give guidance to when a safety assessment should be carried out;~~
 - ~~(ii) outline a suitable safety assessment process that can be used by aerodrome operators;~~
 - ~~(iii) identify the key aspects for conducting, reviewing and evaluation of a safety assessment.~~~~
- ~~(3) The safety assessment process can be used to assess safety risks associated to each identified safety concern in the aerodrome operation.~~

~~(b) Basic considerations~~

- ~~(1) A safety assessment is an element of the risk management process of a Safety Management System that is used to assess safety concerns, such as; identified changes at an aerodrome or when any other safety concerns arise or hazards are identified in the aerodrome infrastructures, systems or operations.~~
- ~~(2) When an identified safety hazard affect service providers on the aerodrome, such as aircraft operators, Air Navigation Service Providers (ANSPs) or ground service providers, the involvement of all the affected parties in the safety assessment process is necessary.~~
- ~~(3) A safety assessment considers the impact of the safety concern, on all relevant factors determined to be safety significant. The list below provides a number of items that may need to be considered when conducting a safety assessment. The items in this list are non-exhaustive and in no particular order:
 - ~~(i) human factors;~~
 - ~~(ii) training;~~~~

~~safety management **system**;~~

- ~~(iii) organisational structure and management;~~
- ~~(iv) aerodrome layout, including runway configurations, runway lengths, taxiway, taxilane and apron configurations, gates, jet bridges, visual aids, RFFS infrastructure and capabilities;~~
- ~~(v) types of aircraft and their dimensions and performance characteristics intended to operate at the aerodrome;~~
- ~~(vi) traffic density and distribution;~~

- ~~(vii) aerodrome ground services;~~
- ~~(viii) air ground communications and time parameters for voice and data link communication;~~
- ~~(ix) type and capabilities of surveillance systems, and the availability of systems providing controller support and alert functions;~~
- ~~(x) flight instrument procedures and related aerodrome equipment;~~
- ~~(xi) operational procedures;~~
- ~~(xii) aerodrome technical installations, such as Advanced Surface Movement Guidance and Control Systems (A-SMGCS) or NAVAIDS;~~
- ~~(xiii) obstacles or hazardous activities at or in the vicinity of the aerodrome;~~
- ~~(xiv) planned construction or maintenance works at or in the vicinity of the aerodrome;~~
- ~~(xv) any significant local or regional weather phenomena;~~
- ~~(xvi) airspace complexity, ATS route structure and classification of the airspace, which may change the pattern of operations or the capacity of the same airspace.~~

~~(4) Subsequent to the completion of the safety assessment that requires mitigation measures, the aerodrome operator is responsible for monitoring the effectiveness of the implemented mitigation measures.~~

~~(5) Any measures taken that result in a change should be adequately promulgated to all affected personnel.~~

~~(6) Documentation of the whole safety assessment process applied with all working documents and results, including a detailed description of the risk assessment conducted for each case analysed should be made available for authority oversight.~~

~~(c) Responsibility~~

~~(1) The Safety Manager is responsible for the management and application of the safety assessment process.~~

~~(2) A safety assessment should be carried out to assess if a particular risk is acceptable within the aerodrome operations or whether mitigation measures are required. When the risk is determined as acceptable the assessment results should be endorsed by an accountable manager within the senior management.~~

~~(3) To protect objectivity, care should be taken to avoid endorsement of safety assessment conclusions by persons within the management who have the responsibility to directly audit subsequent procedures.~~

~~(d) Necessity for conducting a safety assessment~~

~~(1) A safety assessment is carried out for all safety concerns, including; identified safety hazards, deviations from requirements or certification specifications or and identified change or for any other items or circumstances where such an assessment is considered a contribution to safety assurance. A safety assessment is an everyday process at an aerodrome with a functioning management system. It may be applied in different scale depending on the safety concern to be assessed. The list below is not exhaustive but identifies some of the main reasons for a safety assessment to be applied.~~

- ~~(i) An EASA certification specification is not met;~~

- ~~(ii) A hazard is identified, through the voluntary safety reporting system, through an audit or an inspection, internal or external, through an accident or incident report or through any other mechanism;~~
- ~~(iii) A change in applicable requirements;~~
- ~~(iv) The aerodrome undergoes or is affected by a change in infrastructure, systems, processes, procedures, environment or organisation that may impact the safety of aerodrome operations.~~

~~(e) Safety Assessment Process~~

~~(1) Introduction~~

- ~~(i) The primary objective of a safety assessment is to ensure a defined level or attain a higher level of safety by assessing how a specific safety concern affects the safety of aerodrome operations.~~
- ~~(ii) The safety assessment process includes the preparation for processing a safety concern, the safety risk management process, the verification of the adequacy of mitigation measures that may exist or be implemented to reduce the level of risk, the promulgation of safety information derived from the process and subsequent documentation and storage of the entire process.~~
- ~~(iii) The assessment process allows each identified hazard, and associated risk, to be evaluated in order of risk potential so that priorities can be established and, if necessary, resources can be allocated more effectively for the higher risks.~~
- ~~(iv) It is important that, all parties affected by or with a stake in the specific case under review are involved and can contribute to the assessment process. For example changes on an aerodrome often impact several activities; therefore safety assessments for potential hazards associated with changes often need to be carried out in a cross-organisational manner, involving experts from all the involved parties, internal or external, to the aerodrome organisation. Prior to the assessment, a preliminary identification of the required tasks and the organisations to be involved in the process should be conducted.~~
- ~~(v) A safety assessment is initially composed of four basic steps:
 - ~~(A) definition of the safety concern, root cause analysis where appropriate and identification of the relevant regulatory requirements and compliance;~~
 - ~~(B) hazard identification and identification of potential consequences;~~
 - ~~(C) risk assessment;~~
 - ~~(D) mitigation definition, development of mitigation implementation plan, promulgation, documentation and conclusion of the assessment.~~~~
- ~~(vi) Each one of the steps listed in (e)(1)(V) includes a number of detailed procedures, some listed here below, allowing for the full safety assessment process to be conducted. A generic safety assessment process flow chart is provided in Figure 1.~~

~~(2) Definition of the safety concern, root cause analysis where appropriate and identification of the relevant regulatory requirements and compliance.~~

- ~~(i) The perceived safety concern is analysed to determine if it is sustained or rejected. Justification for rejecting the safety concern should be made and~~

~~documented. Sustained safety concern should be precisely described, including timescales and projected phases if relevant, location, involved or affected parties, activities and entities as well as potential influence on specific processes, procedures, systems and operations.~~

~~(ii) An initial evaluation of the compliance with the appropriate provisions in the regulations applicable to the aerodrome is conducted.~~

~~(iii) In order to ensure that the safety assessment addresses the fundamental causes of the safety concern, a root cause analysis is performed and root causes are determined.~~

~~(iv) Where special conditions are established their rationale and justification are identified, documented and taken into account in the risk assessment.~~

~~(v) If a safety assessment has been previously conducted for similar cases (e.g. maintenance of the runway or of the visual aids) in the same context, the aerodrome operator can use some elements from these assessments as a basis for the assessment to be conducted. Nevertheless, as each assessment is specific to a particular safety concern at a given aerodrome the suitability for reusing specific elements of an existing assessment is evaluated.~~

~~(3) Hazard identification and identification of potential consequences~~

~~(i) To actively seek to identify safety hazards related to every aspect of the safety concern various hazard identification methods are applied. These should be conducted in a manner in which there is an acceptable level of confidence that all hazards are identified. It may be supported by brain storming sessions, expert opinion, industry knowledge, operational experience and judgement. The identification of hazards is conducted by at least considering:~~

~~(A) Accident causal factors and critical events based on a simple causal analysis of available accident and incident databases;~~

~~(B) Events that may have occurred in similar circumstances or that have been subsequent to the resolution of a similar problem.~~

~~Prior to implementing changes, hazard identification shall be conducted for potential new hazards that may emerge in the operation during or after implementation of the planned changes.~~

~~(ii) Following the steps listed in (3)(i), for each identified hazard all potential outcomes or consequences are allocated.~~

~~(iii) Where no hazards are identified a safety justification to support that the hazard identification process was complete and correct should be documented and stored.~~

~~(4) Risk assessment overview~~

~~(i) Understanding all the risks is the basis for the subsequent evaluation of existing or potential new mitigation measures that might be needed for safe operations.~~

~~(ii) The level of risk of each identified potential consequence is estimated in the risk assessment. This risk assessment will determine the severity of a consequence and the probability of the consequence occurring.~~

- (iii) ~~The appropriate safety objective for each type of risk is specified in terms of verifiable safety acceptance criteria which may be defined by:~~
- ~~(A) Reference to a safety acceptance criteria associated with recognised standards and/or codes of practices;~~
 - ~~(B) Reference to the safety performance of the existing system;~~
 - ~~(C) Reference to the acceptance of a similar system elsewhere;~~
 - ~~(D) Application of explicit safety risk levels.~~
- (iv) ~~Safety acceptance criteria are specified in either quantitative terms (e.g. identification of a numerical probability) or qualitative terms (e.g. comparison with an existing situation). The selection of the safety acceptance criteria is conducted according to the organisation's policy with respect to safety improvements and is justified for the specific hazard.~~
- (iv) ~~Risk Assessment~~
- ~~(A) The risk assessment takes into account the probability of occurrence of a hazard and the severity of its consequences; the risk is evaluated by combining the two values for severity and probability of occurrence.~~
 - ~~(B) Each identified risk must be classified by probability of occurrence and severity of impact. This process of risk classification will allow the aerodrome to determine the level of risk posed by a particular hazard. The classification of probability and severity refers to potential events.~~
 - ~~(C) The severity classification includes five classes ranging from 'catastrophic' (class A) to 'not significant' (class E). The examples in Table 1 serve as a guide to better understand the definition.~~

Severity class	Definition	Examples
A Catastrophic	<ul style="list-style-type: none"> — accident — equipment destroyed — loss of aircraft — multiple deaths 	<ul style="list-style-type: none"> — mid-air collision between aircraft — collision between aircraft and/or other object during take-off or landing
B Hazardous	<ul style="list-style-type: none"> — a large reduction in safety margins / no safety barriers remaining — the outcome is not under control — major equipment damage — serious or fatal injury to a number of people 	<ul style="list-style-type: none"> — runway incursion, significant potential, (extreme action to avoid collision) — attempted take-off or landing on a closed or engaged runway — take-off / landing incidents, such as undershooting or overrunning — Controlled Flight Into Terrain is only marginally be avoided
C Major	<ul style="list-style-type: none"> — serious incident or accident — significant reduction in safety margins — serious equipment damages — injury to persons 	<ul style="list-style-type: none"> — runway incursion, ample time and distance, (no potential for a collision) — collision with obstacle on apron/ parking position (hard collision) — employee falling down from height — near Controlled Flight Into Terrain — missed approach with ground contact of the wing ends during the touch-down

		<ul style="list-style-type: none"> — large fuel puddle near the aircraft while passengers are on board
D Minor	<ul style="list-style-type: none"> — nuisance, operations limitations — minor incident — small damages to aircraft, vehicles or objects 	<ul style="list-style-type: none"> — hard braking during landing or taxiing — damage due to jet blast (objects) — expendables are laying around the stands — collision between maintenance vehicles on service road — breakage of drawbar during pushback (damage to the A/C) — slight excess of MTOW — aircraft is rolling into PAX bridge (slight collision) — forklift is tilting
E Not significant	<ul style="list-style-type: none"> — non significant consequences — circumstances which may lead to a non significant reduction of safety and no immediate effect on safety 	<ul style="list-style-type: none"> — increase in work load for the crew during taxiing — slight increase of braking distance — hoarding is tumbling down because of strong wind — cart loosing baggage

Table 1: Severity classification scheme with examples

(D) The classification of the severity of an event shall be based on a 'credible case' but not on a 'worst case' scenario. A credible case is expected to be possible under reasonable conditions (probable course of events). A worst case may be expected under extreme conditions and combinations of additional and improbable hazards. If worst cases are to be introduced implicitly, it is necessary to estimate appropriate low frequencies.

(E) The probability classification includes five classes ranging from 'extremely improbable' (class 1) to 'frequent' (class 5). The examples in Table 2 serve as a guide to better understand the definition.

Probability class	Meaning	Definition
5 Frequent	Likely to occur many times (has occurred frequently)	more frequent than once in a year ($>1/y$)
4 Reasonably probable	Likely to occur some times (has occurred infrequently)	once in a year to once in 10 years ($1-0.1/y$)
3 Remote	Unlikely to occur (has occurred rarely)	once in 10 years to once in 100 years ($0.1-0.01/y$)
2 Extremely remote	Very unlikely to occur (not known to have occurred)	once in 100 years to once in 1000 years ($0.01-0.001/y$)
1 Extremely improbable	Almost inconceivable that the event will occur	less than once in 1'000 years ($<0.001/y$)

Table 2: Probability classification scheme

- ~~(F) The probability classes presented in Table 2 are defined with quantitative limits.~~
- ~~(a) The classification refers to the probability of events per year. This is reasoned through the following:~~
- ~~(1) Many hazards at airports are not directly related to aircraft movements.~~
- ~~(2) The assessment of risks should be conducted with the emphasis to minimise use of expert judgement by using where available, appropriate objective methods for evaluating risk.~~
- ~~(b) Frequencies per year are numbers which correspond to experience and they are easier to estimate and validate than extremely small frequencies per movement. If necessary probability per year can easily be transformed into frequencies per movement and vice versa. The following transformation rules must be considered:~~
- ~~(1) Transformation of frequencies per year to frequencies per movement:~~
- ~~(i) The estimated frequency per year shall be divided by the number of movement related to the respective hazard.~~
- ~~(2) Transformation of frequencies per movement to frequencies per year (e.g. if generally known accident rates shall be used for the estimation of a frequency per year):~~
- ~~(i) The known frequency per movement (= rate) shall be multiplied with the related number of movements.~~
- ~~(ii) Example: The failure rate to pass a stop bar on a defined airport is assumed to be 10^{-4} per passage. If 10'000 aircraft will annually pass that stop bar, the frequency will be one stop bar violation per year.~~
- ~~(G) A risk assessment matrix may be used to classify the identified risks. The aim of the matrix is to provide means to obtain a safety risk index for each risk. The index can be used to determine tolerability of the risk and to enable the prioritisation of relevant actions in order to make a decision on risk tolerability and acceptance.~~
- ~~(a) Given that the prioritisation is dependent on both probability and severity of the events, the prioritisation criteria will be two-dimensional. Three main classes of risk priority are defined:~~
- ~~(1) risks with high priority;~~
- ~~(2) risks with mean priority;~~
- ~~(3) risks with low priority.~~
- ~~(b) The risk assessment matrix presented in Table 3 has no fixed limits for tolerability but points to a floating assessment where identified hazards are given risk priority for their risk contribution towards the safety of aerodrome operations. For this reason, the~~

CRD to NPA 2011-20 (B.II)

09/12/201126

AMC/GM to Annex II – Part-OR

Nov 2012

SUBPART D – MANAGEMENT (ADR.OR.D)

~~priority classes are intentionally not edged along the probability and severity classes.~~

Probability		Risk Assessment Matrix				
Frequent	5	High priority				
Reasonably probable	4					
Remote	3			Mean priority		
Extremely remote	2					
Extremely improbable	1					Low priority
Severity		A	B	C	D	E
		Catastrophic	Hazardous	Major	Minor	Not significant

~~Table 3: Risk Assessment matrix with prioritisation classes~~

~~(c) — The definition of the edged limits for the probability and severity classes can be conducted by the aerodrome operator in order to establish the specific level of risk tolerability for the aerodrome operations.~~

~~(5) — Mitigation, verification, promulgation, documentation and conclusion.~~

~~(i) — Risk mitigation~~

~~(A) — In some cases, the result of the risk assessment can be that the safety acceptance criteria are met. In such a case no specific mitigation measures are necessary and the safety assessment process can be documented and stored. In the other cases further measures, operational procedures and operating restrictions to mitigate risks may be required to reduce the frequency of the event occurring or reduce the severity of its consequences until the specified safety acceptance criteria is met.~~

~~(B) — If the risk falls in the high priority, or mean priority areas of the assessment matrix, elimination of the hazard or other mitigation measures will be required to reduce the risk to a lower level. Mitigation measures are actions such as elimination of the risk or changes to operating procedures, equipment or infrastructure that are aimed to reduce either one or both the level of severity and the level of probability.~~

~~(C) — As a general guideline the following actions or measures can be associated with the risk classes defined in (e)(iv)(G)(a):~~

~~(a) — High priority: Urgent mitigation measures may be necessary and, if not already conducted, a detailed safety assessment of the specific hazard shall be performed.~~

- ~~(b) Mean priority: If mitigation measures are identified and provide adequate risk reduction, they shall be applied. A detailed safety assessment should be performed.~~
- ~~(c) Low priority: The hazard shall be further monitored.~~
- ~~(D) Once each hazard is identified, its consequences and associated risks shall be assessed in terms of severity and probability, it must be ascertained that all the assessed hazards are appropriately managed. The exposure to a given hazard is taken into account to decide its acceptability in terms of risk. An initial identification of existing risk mitigation measures are conducted prior to identifying additional mitigation measures.~~
- ~~(E) Once the existing mitigation measures have been identified or additional mitigation measures have been defined, the level of risk needs to be reassessed in terms of severity and likelihood taking into account the further mitigation measures introduced.~~
- ~~(F) All identified risk mitigation measures should be documented and included in an implementation plan. In order to control the risk during implementation, the implementation plan should include the order of implementation, timeframes for implementation, promulgation as well as responsibilities for specific mitigation measures.~~
- ~~(ii) Verification that the mitigation measures reduce risk to an acceptable level may require a safety justification.~~
 - ~~(A) Implementation should begin only after verification of the effectiveness of the mitigation measures, supported by a safety justification.~~
 - ~~(B) The verification of the effectiveness of mitigation measure should be conducted with a review process, such as an inspection, audit or other means.~~
- ~~(iii) Promulgation to all affected personnel and other concerned parties of appropriate safety information derived from the safety assessment shall be ensured.~~
 - ~~(A) In order to ensure adequate dissemination of information to interested parties, safety relevant conclusions of the safety assessment should be promulgated in the relevant aerodrome documentation or information systems.~~
 - ~~(B) The promulgation of this information may be done by amending the appropriate procedures in the Aerodrome Manual, direct documented communication to the concerned personnel and parties, through the Aeronautical Information Publication (AIP), Notice to Airmen (NOTAM) Automated Terminal Information Service (ATIS) or by other relevant means.~~
- ~~(iv) Documentation and storage~~
 - ~~(A) The safety assessment is documented and stored according to the aerodrome operator's SMS documentation procedures.~~
 - ~~(B) The safety assessment documentation has to be accessible in its entirety and readily available to be presented to the competent authority for oversight purposes.~~

CRD to NPA 2011-20 (B.II)
AMC/GM to Annex II – Part-OR
SUBPART D – MANAGEMENT (ADR.OR.D)

09/12/2011
26
Nov 2012

~~(C) The safety assessment is concluded by ensuring it is referred to the appropriate regular review process.~~

Safety Assessment Flowchart Part 1

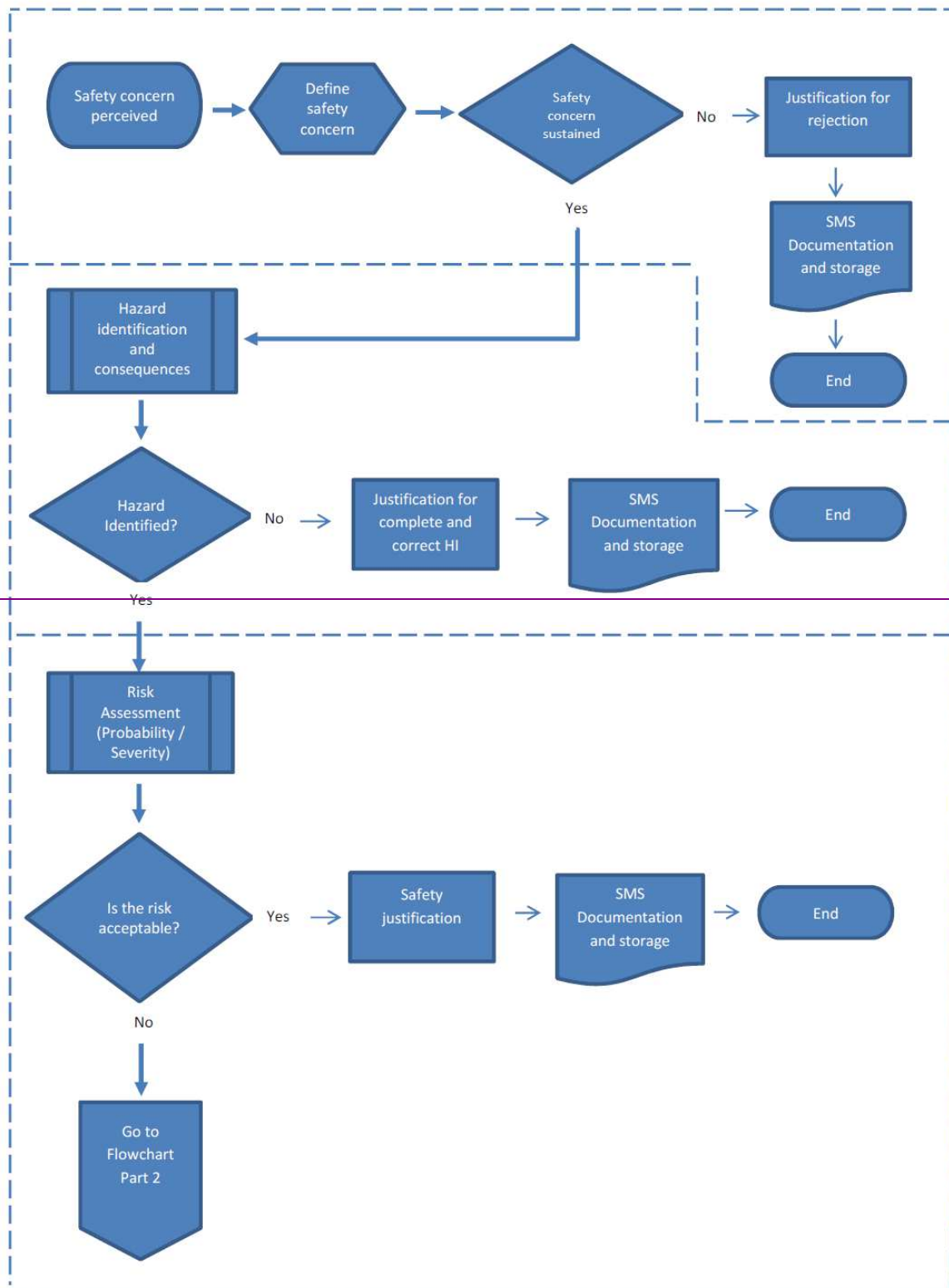

Safety Assessment Flowchart part 2

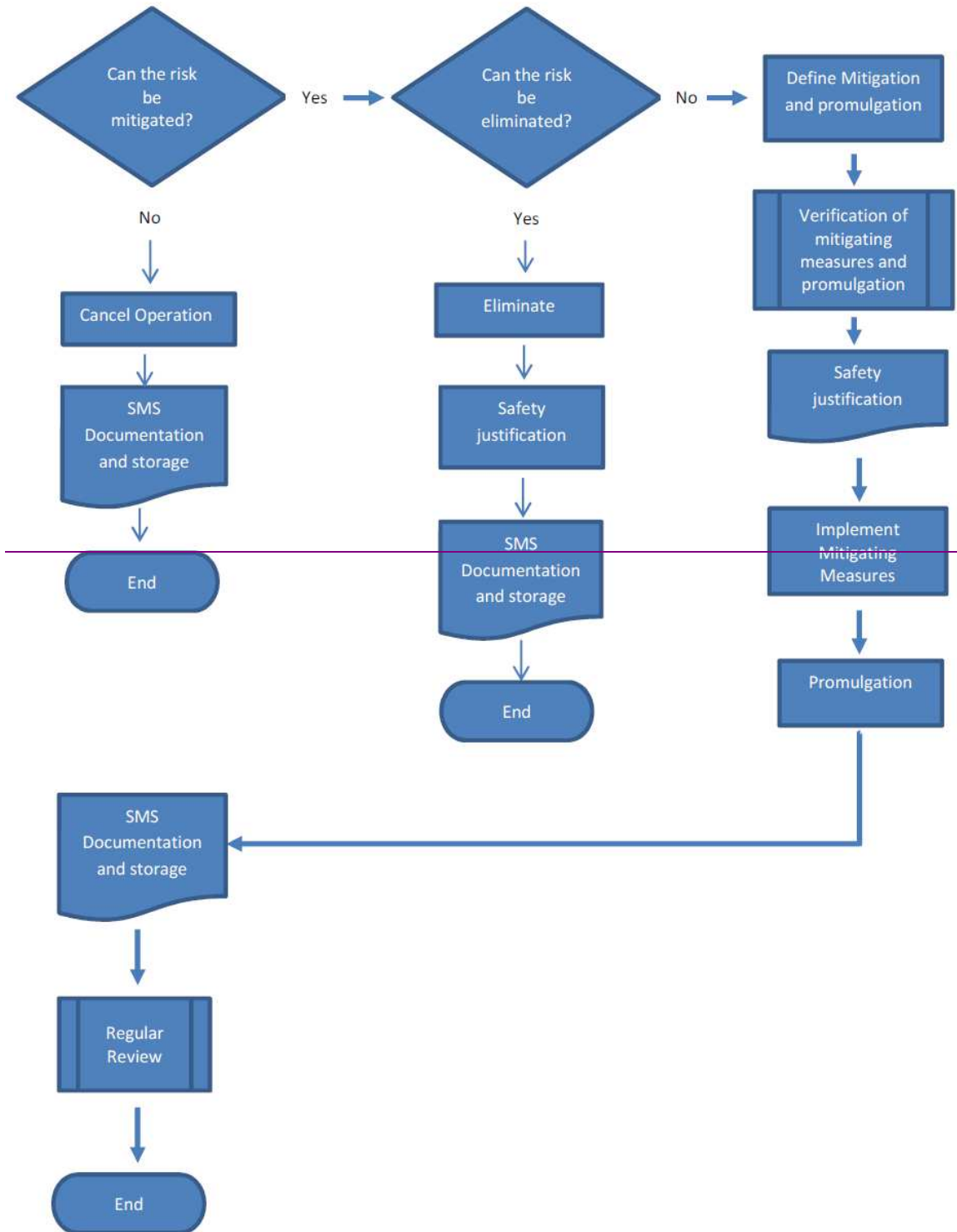

Figure 1 — Safety Assessment Process Flow Charts Part 1 and 2

~~(f) Regular review~~

- ~~(1) Changes applied after safety assessments should be reviewed at regular intervals to determine if the risk controls are still valid.~~
- ~~(2) If any of the factors involved in the safety assessment that was conducted have changed either the entire safety assessment or relevant parts will need to be reviewed in order to determine the new level of implied risk and adequacy of risk mitigation measures.~~
- ~~(3) The regular review can be included in the regular internal audit schedule or conducted through a separate review process established and documented in the aerodrome manual.~~

~~(g) Submitting a safety assessment to the competent authority~~

- ~~(1) A safety assessment should be registered and documented according to SMS documentation procedures and when requested for review or approval as foreseen in the applicable requirements, submitted to the competent authority to show that the aerodrome operator has suitably assessed the safety concern and taken subsequent actions as appropriate for elimination or mitigation measures.~~

~~AMC1 ADR.OR.D.005(b)(5) Management~~

SAFETY PERFORMANCE MONITORING AND MEASUREMENT

- (a) Safety performance monitoring and measurement should be the process by which the safety performance of the aerodrome operator is verified in comparison to the safety policy and objectives, identified safety risks and the mitigation measures.
- (b) This process should include: the setting of safety performance indicators, and measuring the aerodrome operator's safety performance against them.

~~GM1 ADR.OR.D.005(b)(5) Management system~~

SAFETY PERFORMANCE MONITORING AND MEASUREMENT

(a) The performance monitoring and measurement process should include:

- (1) safety reporting, addressing also the status of compliance with the applicable requirements;
- (2) safety studies, which are rather large analyses encompassing broad safety concerns;
- (3) safety reviews including trends reviews, which are conducted during introduction and deployment of new technologies, change or implementation of procedures, or in situations of structural change in operations, or to explore increase in incidents or safety reports;
- (4) safety audits which focus in the integrity of the aerodrome operator's management system, and periodically assess the status of safety risk controls;
- (5) safety surveys, which examine particular elements or procedures of a specific operation, such as problem areas or bottlenecks in daily operations, perceptions and opinions of operational personnel, and areas of dissent or confusion; and

- (6) internal safety investigations, whose scope should extend the scope of occurrences required to be reported to the ~~competent authority;~~ Competent Authority;

~~(f)(n) setting safety performance indicators and measuring performance against them.~~

~~GM1-ADR.OR.D.005(b)(5) — Management~~

~~SAFETY PERFORMANCE MONITORING AND MEASUREMENT~~

- (b) The following generic aspects/areas could be considered:
- (1) accountability for management of the operational activities and its ultimate accomplishment;
 - (2) authority to direct, control, or change the procedures, as well as to make key decisions such as safety risk acceptance decisions;
 - (3) procedures for operational activities;
 - (4) controls, including hardware, software, special procedures or procedural steps, and supervisory practices designed to keep operational activities on track;
 - (5) interfaces, including lines of authority between departments, lines of communication between employees, consistency of procedures, and clear delineation of responsibility between organisations, work units, and employees; and
 - (6) process measures to provide feedback to responsible parties that required actions are taking place, required outputs are being produced, and expected outcomes are being achieved.

~~AMC1-ADR.OR.D.005(b)(6) — Management system~~

THE MANAGEMENT OF CHANGE

The aerodrome operator should manage safety risks related to a change. The management of change should be a documented process to identify external and internal change that may have an adverse effect on safety.

It should make use of the aerodrome operator's existing hazard identification, safety risk assessment, and mitigation processes.

~~GM1 For assessment of changes ADR.OR.B.045 and its related AMCs also apply.~~

~~GM1-ADR.OR.D.005(b)(6) — Management system~~

THE MANAGEMENT OF CHANGE

- (a) Change can introduce new hazards, impact the appropriateness and/or effectiveness of existing safety risk mitigation strategies. Changes may be external to the organisation, or internal.
- (b) A formal process for the management of change should take into account the following considerations:
- (1) ~~Criticality~~criticality of systems and activities;
 - (2) ~~Stability~~stability of systems and operational environments; and

(3) ~~Past~~ performance.

- (c) System description is one of the fundamental preliminary activities in the planning of the safety management system, to determine a baseline hazard analysis for the baseline system.

As part of the formal process of the management of change, the system description and the baseline hazard analysis should be reviewed periodically, even if circumstances of change are not present, to determine their continued validity.

When changes to the system are made, and periodically thereafter, the aerodrome operator should go over its system and its actual operational environment, in order to make sure it continues to be fully aware of the circumstances under which the provision of services takes place.

~~Further guidance on~~ With regard to the management of change ~~is contained in ICAO Doc 9859 and safety assessments related to changes, see also ADR.OR.B.040 and GM1 ADR.OR.B.040(f).~~

AMC1- ADR.OR.D.005(b)(7) – Management system

CONTINUOUS IMPROVEMENT OF THE SAFETY MANAGEMENT SYSTEM

The aerodrome operator should continuously seek to improve its safety performance. The aerodrome operator should develop and maintain a formal process to identify the causes of substandard performance of the Safety Management System, determine the implications of substandard performance of the Safety Management System in operations, and eliminate or mitigate such causes. Continuous improvement should be achieved through:

- (a) proactive and reactive evaluation of facilities, equipment, documentation, and procedures;
- (b) proactive evaluation of an individual's performance, to verify the fulfilment of that individual's safety responsibilities; and
- (c) reactive evaluations in order to verify the effectiveness of the system for control and mitigation of safety risks.

AMC2- GM1 ADR.OR.D.005(b)(7) – Management

~~CONTINUOUS IMPROVEMENT OF THE QUALITY AND SECURITY MANAGEMENT FOR AERONAUTICAL DATA AND AERONAUTICAL INFORMATION PROVISION ACTIVITIES~~

~~The aerodrome operator should develop and maintain a formal process to identify the causes of substandard performance of the Quality and Security Management Systems for aeronautical data and aeronautical information provision activities, determine the implications of their substandard performance in operations, and eliminate or mitigate such causes. Continuous improvement should be achieved through:~~

- ~~(a) proactive evaluation of facilities, equipment, documentation and procedures;~~
- ~~(b) proactive evaluation of an individual's performance, to verify the fulfilment of that individual's responsibilities;~~

~~reactive evaluations in order to verify the effectiveness of the system for control and mitigation of risks.~~

~~GM1~~ **ADR.OR.D.005(b)(7) – Management**

CONTINUOUS IMPROVEMENT OF THE SAFETY MANAGEMENT SYSTEM

Continuous improvement of the safety management system, as part of the safety assurance, is achieved through the application of:

- (a) internal evaluations;
- (b) independent audits (both internal and external);
- (c) strict document controls; and
- (d) continuous monitoring of safety controls and mitigation actions.

~~Further guidance on continuous improvement of the safety management system is contained in ICAO Doc 9859.~~

AMC1-ADR.OR.D.005(b)(8) – Management system

SAFETY MANAGEMENT SYSTEM TRAINING

~~(a) The aerodrome operator should establish a safety management system training programme to for all staff, regardless of their level in the organisation.~~

~~(b) The safety training programme should consist of the following:~~

~~(1) a documented process to identify training requirements for each area of activity within the aerodrome organisation, operations, rescue and track completion of required training;~~

~~(1) a validation process that measures the effectiveness of training;~~

~~(2) initial job-specific training;~~

~~(2) induction/initial training incorporating safety management system, including Human Factors, firefighting, and organisational factors; and~~

~~(3) recurrent safety training.~~

~~(c) A training file should be developed for each employee, including management, to assist in identifying and tracking employee training requirements and verifying that maintenance personnel have received the planned training.~~

~~(a) The, including all management personnel of the aerodrome operator should specify initial and recurrent safety training standards for operational personnel, managers and (e.g. supervisors, managers, senior managers, and the accountable manager.), regardless of their level in the aerodrome operator's organisation.~~

~~(d)(b) The amount and level of detail of safety training should be proportionate and appropriate to the individual's responsibility and involvement in the SMS safety management system.~~

~~(e) The aerodrome operator should specify safety training responsibilities, including contents, frequency, validation and safety training records management.~~

~~(f) The information provided in points (d) and (e) above should be included in the aerodrome manual.~~

~~(d)(c) This system training programme may should be combined developed in accordance with the AMC1 ADR.OR.D.017(a), and be incorporated in the training programme provided for in AMC1-ADR.OR.D.015 (h)-foreseen therein.~~

GM1-ADR.OR.D.005(b)(8) – Management system

STAFF SAFETY MANAGEMENT SYSTEM TRAINING REQUIREMENTS

- (a) ~~Operational~~Operations, rescue and fire-fighting, and maintenance personnel
- (1) Safety training should address safety responsibilities, including adherence to all operating and safety procedures, and recognising and reporting hazards;
 - (2) The training objectives should include the organisation's safety policy and SMSsafety management system fundamentals, and overview;
 - (3) The contents should include:
 - (i) definition of hazards;
 - (ii) consequences and risks;
 - (iii) the safety risk management process, including roles and responsibilities; and
 - (iv) safety reporting and the organisation's safety reporting system(s).
- (b) Managers and supervisors
- (1) Safety training should address safety responsibilities, including promoting the SMS and engaging operational personnel in hazard reporting;
 - (2) In addition to the training objectives established for operational personnel, training objectives for managers and supervisors should include a detailed knowledge of the safety process, hazard identification and safety risk management and mitigation, and change management;
 - (3) In addition to the contents specified for operational personnel, the training contents for supervisors and managers should include safety data analysis.
- (c) Senior managers
- (1) Safety training should include safety responsibilities, including compliance with European Union, national and the organisation's own safety requirements, allocation of resources, ensuring effective inter-departmental safety communication, and active promotion of the SMSsafety management system;
 - (2) In addition to the objectives of the two previous employee groups, safety training should include safety assurance and safety promotion, safety roles and responsibilities, and establishing acceptable levels of safety.
- (d) Accountable manager
- The training should provide the accountable manager with a general awareness of the organisation's safety management system, including safety management system roles and responsibilities, safety policy and objectives, safety risk management, and safety assurance.

~~Further guidance on the issue staff safety training is contained in ICAO Doc 9859.~~

AMC1-ADR.OR.D.005(b)(9) – Management system

SAFETY COMMUNICATION

- (a) The aerodrome operator should communicate safety management system objectives and procedures to all operational personnel, and the SMS safety management system and its application should be visible/evident in all aspects of operations.
- (b) Communication should flow between the safety manager and operational personnel throughout the organisation. The safety manager should communicate the performance of the organisation's safety management system through suitable means. The safety manager should, also, ensure that lessons learned from investigations, safety related events, or other safety related experiences, both internally and from other organisations, are distributed widely.
- (c) Safety communication should aim to:
 - (1) ensure that all staff are fully aware of the safety management system;
 - (2) convey safety-critical information;
 - (3) explain why particular actions are taken; and
 - (4) explain why safety procedures are introduced or changed.

GM1-ADR.OR.D.005(b)(9) – Management system

SAFETY COMMUNICATION

- (a) An aerodrome operator, may use the following tools to communicate safety information:
- (1) ~~safety~~Safety Management System Manual;
 - (2) safety processes and procedures;
 - (3) safety newsletters, notices, and bulletins; and
 - (4) websites or emails;
- (b) Regular meetings with personnel where information, actions, and procedures are discussed may be used to communicate safety matters.

~~Further guidance on safety communication is contained in ICAO Doc 9859.~~

AMC1-ADR.OR.D.005(b)(10) – Management system

COORDINATION OF THE AERODROME EMERGENCY RESPONSE PLAN

The coordination of the aerodrome emergency response plan, established in accordance with the requirements contained in Part-ADR.OPS, with the safety management system should ensure continuous improvement of the systems and procedures contained within the plan.

GM1 ADR.OR.D.005(b)(10) Management system

COORDINATION OF THE AERODROME EMERGENCY RESPONSE PLAN

Continuous improvement of the systems and procedures contained within the aerodrome emergency response plan may, amongst others, be obtained by:

- (a) conducting a review of the relevant parts of the emergency response plan after a full or partial exercise;
- (b) debriefing and analysing the emergency response operations after an emergency situation; and
- (c) developing new emergency procedures or systems as part of the emergency response plan when new hazards are identified by the safety management system,

to ensure, amongst others, the coordination with the emergency response plans of other interfacing organisations.

AMC1-ADR.OR.D.005(e)–b)(11) Management

~~AERODROME OPERATOR MANAGEMENT SYSTEM DOCUMENTATION~~

~~The aerodrome operator's management system documentation should at least include the following information:~~

COMPLIANCE MONITORING

- (a) ~~a statement signed by the accountable manager to confirm that the aerodrome operator will continuously work in accordance with the applicable requirements and the operator's documentation;~~
- (b) ~~the aerodrome operator's scope of activities;~~

- ~~(1) the titles and names of persons referred to in ADR.OR.D.015;~~
- ~~(c) an organisation chart showing the lines of responsibility between the persons referred to in ADR.OR.D.005 (b)(1);~~
- ~~(d) a general description and location of the facilities;~~
- ~~(e) procedures specifying how the aerodrome operator ensures compliance with the applicable requirements;~~
- ~~(f) the amendment procedure for the operator's management system documentation; and~~
- ~~(g) safety management system outputs.~~

~~AMC2-ADR.OR.D.005(c) – Management~~

~~AERODROME OPERATOR SAFETY MANAGEMENT MANUAL~~

- ~~(a) In cases where safety management is set out in a Safety Management Manual (SMM) it should be the key instrument for communicating the approach to safety for the aerodrome operator. The SMM should document all aspects of safety management, including the safety policy, objectives, procedures and individual safety responsibilities;~~
- ~~(b) The contents of the documentation should include:
 - ~~2.2.1 scope of the safety management system;~~
 - ~~2.2.2 safety policy and objectives;~~
 - ~~2.2.3 safety responsibilities of key safety personnel;~~
 - ~~2.2.4 documentation control procedures;~~~~
- ~~(1) safety assessment process including hazard identification and risk management schemes;~~
- ~~(2) monitoring of implementation and effectiveness of safety actions and risk mitigation measures;~~
- ~~(3) safety performance monitoring;~~
- ~~(4) hazard reporting system;~~
- ~~(5) incident reporting and investigation;~~
- ~~(6)(1) emergency response planning;~~
- ~~(7)(2) management of change (including organisational changes with regard to safety responsibilities);~~
- ~~(8)(3) safety promotion; and~~
- ~~(9)(4) safety management system outputs.~~

~~GM1-ADR.OR.D.005(c) – Management~~

~~AERODROME OPERATOR MANAGEMENT SYSTEM DOCUMENTATION~~

~~It is not required to duplicate information in several manuals. The Safety Management Manual is considered to be a part of the aerodrome manual.~~

~~AMC1-ADR.OR.D.005(d) – Management~~

COMPLIANCE MONITORING

(a) Compliance monitoring

~~GENERAL~~

- (1) The implementation and use of a compliance monitoring ~~function~~process should enable the aerodrome operator to monitor compliance with the relevant requirements of this Part, Part-ADR.OPS₂ and any other applicable requirements.

The aerodrome operator should specify the basic structure of the compliance monitoring ~~function~~ applicable to the activities conducted₂.

The compliance monitoring ~~function~~ should be structured according to the size of organisation and the complexity of the activities to be monitored, including those which have been ~~sub-contracted~~subcontracted.

Compliance monitoring should include a feedback system of findings to the accountable manager to ensure effective implementation of corrective actions as necessary.

- (2) An aerodrome operator should monitor compliance with the procedures₂ it has designed₂ to ensure safe activities. In doing so, an aerodrome operator should as a minimum, and where appropriate, monitor:
- (1) organisational structure;
 - (2) plans and objectives;
 - ~~(1) privileges of the organisation;~~
 - (3) manuals, logs₂ and records;
 - (4) training standards;
 - (5) required resources; and
 - (6) management system procedures and manuals.

~~AMC2-ADR.OR.D.005(d) — Management~~

COMPLIANCE MONITORING DOCUMENTATION

(b) Organisational set-up

- (1) To ensure that the aerodrome operator continues to meet the requirements of this Part, Part-ADR.OPS and other applicable requirements, a compliance monitoring manager should be nominated (see AMC2-ADR.OR.D.005(11)) by the aerodrome operator. The role of the compliance monitoring manager is to ensure that the activities of the aerodrome operator, are monitored for compliance with the applicable regulatory requirements, and any additional requirements as established by the aerodrome operator, and that these activities are being carried out properly under the supervision of the relevant head of each functional area.
- (2) The compliance monitoring manager should be responsible for ensuring that the compliance monitoring programme is properly implemented, maintained and continually reviewed and improved.
- (3) In the case the same person acts as compliance monitoring manager and as safety manager, the accountable manager, with regards to his/her direct accountability for safety, should ensure that sufficient resources are allocated to both functions.

taking into account the size of the aerodrome operator, and the nature and complexity of its activities.

- (4) The independence of the compliance monitoring should be established by ensuring that audits and inspections are carried out by personnel not responsible for the function, procedure, etc. being audited.

(c) Compliance monitoring documentation

- (1) Relevant documentation should include the relevant part(s) of the aerodrome operator's management system documentation.
- (2) In addition, relevant documentation should also include the following:
 - (i) terminology;
 - (ii) specified activity standards;
 - (iii) a description of the organisation of the aerodrome operator;
 - (iv) the allocation of duties and responsibilities;
 - (v) procedures to ensure regulatory compliance;
 - (vi) the compliance monitoring programme, reflecting:
 - (A) schedule of the monitoring programme;
 - (B) audit procedures;
 - (C) reporting procedures;
 - (D) follow-up and corrective action procedures; and
 - (E) recording system;
 - (vii) the training syllabus for compliance monitoring; referred to in (d)(2); and
 - (viii) document control.

(a)(d) Training

(1) Staff Correct and thorough training is essential to optimise compliance in every aerodrome operator. In order to achieve significant outcomes of such training, the operator should ensure that all personnel understand the objectives as laid down in the operator's management system documentation.

(1)(2) The staff responsible for managing the compliance monitoring function/mechanism should receive training on this task. Such training should cover the requirements of compliance monitoring, manuals and procedures related to the task, audit techniques, reporting, and recording.

(2)(3) Time should be provided to train all personnel involved in compliance management, and for briefing the remaining personnel; and.

(3)(4) The allocation of time and resources should be governed by the volume and complexity of the activities concerned.

~~AMC3-ADR.OR.D.005(d) — Management~~

(b)(e) COMPLIANCE MONITORING — STAFFING—Auditors

Auditors used for compliance monitoring audits and inspections should ~~meet the following criteria:~~

- ~~(a) should not have involvement in the area of the activity which is be able to be audited;~~
- ~~(b) should have demonstrate relevant operational knowledge, background and/or maintenance experience or other appropriate experience;~~
- ~~external auditors used, should be familiar with the type of operation, maintenance or other related to the activities of the aerodrome operator, including knowledge and experience in compliance monitoring.~~

~~AMC4 ADR.OR.D.005(d) Management~~

~~COMPLIANCE MONITORING – AUDIT SCHEDULING~~

- ~~(f) The compliance Compliance monitoring function should include a – audit scheduling~~
- (1) ~~A~~ defined audit schedule and a periodic review cycle for each area. ~~The aerodrome operator should ensure that the be. The compliance monitoring function is itself should also be~~ audited according to a defined audit schedule. The schedule should allow for unscheduled audits when trends are identified. Follow-up audits should be scheduled to verify that corrective action was carried out, and that it was effective and completed, in accordance with the policies and procedures specified in the aerodrome manual.
- (2) ~~An aerodrome operator should establish a~~ schedule of audits to be completed during a specified calendar period should be established. All aspects of the aerodrome and its operation should be audited within the first 12 months since the date of the issuance of the certificate. After that, an audit or a series of audits should be conducted within a maximum period of 36 months, to cover the whole aerodrome and its operation in a manner, and at intervals set out in the aerodrome manual, unless the ~~competent authority~~ Competent Authority requires further audits.

AMC2 ADR.OR.D.005(b)(11) Management system

COMPLIANCE MONITORING MANAGER

- (a) The compliance monitoring manager should:
- (1) act independently of other managers within the organisation, and should have direct access to the accountable manager and to appropriate management for safety matters. The compliance monitoring manager should be responsible to the accountable manager;
- (2) not be one of the persons referred to in ADR.OR.D.015(b) or ADR.OR.D.015(c), except that in less complex aerodrome organisation/operations, this task may also be exercised by the accountable manager or the person referred to in ADR.OR.D.015(c), provided he/she has demonstrated having the related competence as defined in paragraph (b); and
- ~~(1)~~(3) have access to all parts of the organisation, and as necessary, any contracted organisation.
- (b) The compliance monitoring manager should have:
- (1) adequate practical experience and expertise in aerodrome operations, or maintenance, or similar area;

- (2) adequate knowledge of safety and quality assurance principles and management;
- (3) knowledge of the aerodrome manual; and
- (1)(4) comprehensive knowledge of the applicable requirements in the area of aerodrome.

GM1 ADR.OR.D.005(b)(11) Management system

COMPLIANCE MONITORING – GENERAL

- (a) The organisational set-up of the compliance monitoring should reflect the size of the aerodrome operator, and the nature and complexity of its activities. The compliance monitoring manager may perform all audits and inspections himself/herself, or appoint one or more auditors by choosing personnel having the related competence as defined in paragraph (e) of AMC1 ADR.OR.D.005(b)(11) either from within, or outside the aerodrome operator.
- (b) Regardless of the option chosen, it must be ensured that the independence of the audit function is not affected, in particular, in cases where those performing the audit or inspection are also responsible for other functions for the aerodrome operator.
- (c) In case external personnel are used to perform compliance audits or inspections:
 - (1) any such audits or inspections are performed under the responsibility of the compliance monitoring manager; and
 - (2) the aerodrome operator remains responsible to ensure that the external personnel has relevant knowledge, background, and experience as appropriate to the activities being audited or inspected, including knowledge and experience in compliance monitoring.
- (d) The aerodrome operator retains the ultimate responsibility for the effectiveness of the compliance monitoring, in particular for the effective implementation and follow-up of all corrective actions.

AMC1 ADR.OR.D.005(c) Management system

AERODROME OPERATOR MANAGEMENT SYSTEM DOCUMENTATION

The aerodrome operator should ensure that the documented management system key processes include a process for making personnel aware of their responsibilities, as well as its amendment procedure.

The aerodrome operator's management system documentation should, at least, include the following information:

- (h) a statement signed by the accountable manager to confirm that the aerodrome operator will continuously work in accordance with the applicable requirements and the operator's documentation;
- (i) the aerodrome operator's scope of activities;
- (j) the titles and names of persons referred to in ADR.OR.D.015 ~~AMC1~~ and AMC2-ADR.OR.D.005(b)(11);
- ~~(j)~~(k) an organisation chart showing the lines of responsibility between the nominated persons;
- ~~(k)~~(l) a general description and location of the facilities;
- ~~(l)~~(m) procedures specifying how the aerodrome operator ensures compliance with the applicable requirements;
- ~~(m)~~(n) the amendment procedure for the operator's management system documentation; and
- ~~(n)~~(o) safety management system outputs.

AMC2 ADR.OR.D.005(c) Management system

AERODROME OPERATOR SAFETY MANAGEMENT MANUAL

(b) In cases where safety management is set out in a Safety Management Manual, it should be the key instrument for communicating the approach to safety for the aerodrome operator. The Safety Management Manual should document all aspects of safety management, including the safety policy, objectives, procedures, and individual safety responsibilities.

(c) The contents of the Safety Management Manual should include:

- (1) scope of the safety management system;
- (2) safety policy and objectives;
- (3) safety responsibilities of key safety personnel;
- (4) documentation control procedures;
- (5) safety assessment process, including hazard identification and risk management schemes;
- (6) monitoring of implementation and effectiveness of safety actions, and risk mitigation measures;
- (7) safety performance monitoring;
- (8) safety reporting (including hazard reporting) and investigation;
- ~~(10)~~(9) coordination of emergency response planning;

- ~~(11)~~(10) management of change (including organisational changes with regard to safety responsibilities);
~~(12)~~(11) safety promotion; and
~~(13)~~(12) safety management system outputs.

GM1 ADR.OR.D.005(c) Management system

AERODROME OPERATOR MANAGEMENT SYSTEM DOCUMENTATION

It is not required to duplicate information in several manuals. The Safety Management Manual is considered to be a part of the aerodrome manual.

AMC1 ADR.OR.D.007(a) Management of aeronautical data and aeronautical information

QUALITY MANAGEMENT SYSTEM

- (a) A quality management system supporting the origination, production, storage, handling, processing, transfer, and distribution of aeronautical data and aeronautical information should:
- (4) define the quality policy in such a way as to meet the needs of different users as closely as possible;
 - (5) set up a quality assurance programme that contains procedures designed to verify that all operations are being conducted in accordance with the applicable requirements, standards and procedures, including the relevant requirements of Part-ADR.OPS;
 - ~~(5)~~(6) provide evidence of the functioning of the quality system by means of manuals and monitoring documents;
 - ~~(6)~~(7) appoint management representatives to monitor compliance with, and adequacy of, procedures to ensure safe and efficient operational practices; and
 - (8) perform reviews of the quality system in place, and take remedial actions, as appropriate.
- (b) An EN ISO 9001 certificate, issued by an appropriately accredited organisation, is considered as an Acceptable Means of Compliance.

GM1 ADR.OR.D.007(a) Management of aeronautical data and aeronautical information

An aerodrome operator does not need to duplicate functions and activities in order to discharge the responsibilities related to the management of aeronautical data and aeronautical information provision activities.

In this respect, the compliance monitoring may be used for the purposes of ensuring compliance with the relevant requirements for management of aeronautical data and aeronautical information provision activities.

AMC2 ADR.OR.D.007(b) Management of aeronautical data and aeronautical information

SECURITY MANAGEMENT FOR AERONAUTICAL DATA AND AERONAUTICAL INFORMATION PROVISION ACTIVITIES

~~(d)~~(c) The security management objectives should be:

- (1) to ensure the security of aeronautical data and aeronautical information received, produced, or otherwise employed so that it is protected from interference, and access to it is restricted only to those authorised; and
- (2) to ensure that the security management measures meet appropriate national, EU, or international requirements for critical infrastructure and business continuity, and international standards for security management, including:
 - (ii) ISO/IEC 17799:2005 – Information technology – Security techniques – Code of practice for information security management
 - ~~(ii)~~(iii) ISO 28000:2007: – Specification for security management systems for the supply chain.

~~(e)~~(d) Regarding the ISO standards, the relevant certificates issued by an appropriately accredited organisation, are considered as an Acceptable Means of Compliance.

AMC1 ADR.OR.D.010 – Contracted activities

COMPLIANCE MONITORING – RESPONSIBILITY WHEN CONTRACTING ACTIVITIES

- (a) An aerodrome operator may ~~decide to~~ contract certain activities to external organisations.
- (b) A contract/written agreement should exist between the aerodrome operator and the contracted organisation, clearly defining the contracted activities and the applicable requirements.
- (c) The contracted safety related activities relevant to the agreement should be included in the operator's safety ~~assurance process;~~ management and compliance monitoring programmes.
- (d) The aerodrome operator should ensure that the contracted organisation has the necessary authorisation, declaration, or approval when required, and commands the resources and competence to undertake the task; to this end, a prior audit of the contracted party should be conducted to ensure that the contracted organisation meets the applicable requirements, and the requirements specified by the aerodrome operator's itself.

If

GM1 ADR.OR.D.010 Contracted activities

CONTRACTING – GENERAL

- (a) Contracted activities to external organisations for the provision of services may include areas such as:
 - (1) maintenance of the aerodrome and equipment;
 - (2) surveying for aeronautical data;
 - (3) apron management services;

(4) training;

(5) rescue and firefighting services;

(6) aerodrome design, etc.

(b) In case of contracted activities, the aerodrome operator requires the contracted should define relevant management responsibilities within its own organisation to conduct an activity which exceeds the contracted organisation's authorisation.

(c) The ultimate responsibility for the product or approval, service provided by external organisations should always remain with the aerodrome operator.

GM2 ADR.OR.D.010 Contracted activities

RESPONSIBILITY WHEN CONTRACTING ACTIVITIES

(a) Regardless of the approval status of the contracted organisation, the contracting operator is responsible for ensuring to ensure that the all contracted organisation's activities are subject to hazard identification, risk assessment and mitigation, as well as compliance monitoring takes account of such additional requirements.

(b) When the contracted organisation is itself certified to carry out the contracted activities, the aerodrome operator's compliance monitoring should at least check that the approval effectively covers the contracted activities, and that it is still valid.

AMC1- ADR.OR.D.015(a) – Personnel requirements

ACCOUNTABLE MANAGER

(a) Accountable Manager – General

(1) The accountable manager should:

- (i) ensure that all necessary resources are available to operate the aerodrome in accordance with the Aerodrome Manual applicable requirements and the aerodrome manual;
- (ii) ensure that, if there is a reduction in the level of resources or abnormal circumstances which may affect safety, the required reduction in the level of operations at the aerodrome is implemented;
- (iii) establish, implement, and promote the safety policy; and
- (iv) ensure compliance with relevant applicable requirements, certification basis, and the organisation's safety management system, as well as its quality and security management system with regard to aeronautical data and aeronautical information provision activities.

(2) The accountable manager should have:

- (i) an appropriate level of authority within the aerodrome operator's organisation to ensure that activities are financed and carried out to the standard required;
- (ii) knowledge and understanding of the documents that prescribe relevant aerodrome safety standards;
- (iii) understanding of the requirements for competence of aerodrome management personnel, so as to ensure that competent persons are in place;

- (iv) knowledge and understanding of safety, quality, and security management systems related principles and practices, and how these are applied within the organisation;
- (v) knowledge of the role of the accountable manager; and
- (vi) knowledge and understanding of the key issues of risk management within the aerodrome.

~~AMC2~~ **ADR.OR.D.015(a) – Personnel requirements**

~~ACCOUNTABLE MANAGER~~

~~(b) If the Accountable manager – Delegation of responsibilities mentioned in paragraph (c) are delegated, the level of~~

- (1) ~~The~~ technical knowledge and understanding expected ~~of~~by an accountable manager is high level, with particular reference to his/her own role in ensuring that standards are maintained. ~~If the responsibilities mentioned in paragraph (c) are not delegated, the accountable manager should meet the qualification requirements for each non-delegated task and responsibility;~~
- (2) During periods of absence, the day-to-day responsibilities of the accountable manager may be delegated; however, the accountability ultimately remains with the accountable manager.
- (3) Depending on the size and the complexity of operations, the accountable manager may delegate ~~some of the~~his/her responsibilities ~~to other persons within the organisation, who have demonstrated that they possess adequate experience, knowledge and technical expertise in those areas. Such~~the area of training, by nominating a training manager whose responsibilities could should be: the establishment, coordination, implementation, and relevant record keeping of personnel training, as well as proficiency check programmes.
 - ~~(i) the day to day management of aerodrome operations, coordination with Air Traffic Services and Apron Management Services;~~
 - ~~(ii) establishment and implementation of an aerodrome emergency plan and the provision of adequate rescue and fire fighting services;~~
 - ~~(iii) implementation and maintenance of an appropriate aerodrome wildlife risk management programme;~~
 - ~~(iv) establishment and implementation of an appropriate aerodrome infrastructure maintenance programme;~~
 - ~~(v) establishment, implementation, coordination and recording of a personnel training programme; and~~
 - ~~(vi) the implementation and management of the quality and security management of aeronautical data and aeronautical information provision activities.~~

In any case, the accountability, ultimately, remains with the accountable manager.

~~GM2~~ **GM1 ADR.OR.D.015(a) – Personnel requirements**

ACCOUNTABLE MANAGER

~~OPERATIONS MANAGEMENT~~

- ~~(a) The management of the day to day operations may include, but not limited to:~~
- ~~(1) aerodrome inspections (including visual aids inspections) according to the provisions of the Aerodrome Manual;~~
 - ~~(2) timely and efficient application of wildlife risk management measures;~~
 - ~~(3) implementation of the procedures related to aerodrome operations in winter operations, adverse weather conditions, reduced visibility or at night, if required;~~
 - ~~(4) measurement of runway friction coefficient, when required;~~
 - ~~(5) implementation of procedures to control works Depending on the movement area;~~
 - ~~(6) monitoring size, structure and complexity of obstacles around the aerodrome;~~
 - ~~(7) implementation of procedures related to aerodrome emergency plan;~~
 - ~~(8) coordination with the local Air Navigation Services Provider; and~~
 - ~~(9) coordination with Apron Management Services.~~

~~EMERGENCY PLAN MANAGEMENT~~

- ~~(a) The emergency plan management may include, but not limited to:~~
- ~~(1) establishment of an aerodrome emergency plan;~~
 - ~~(2) coordination with other organisations, such as aircraft operators, air navigation service provider, ground handling services providers and Local/State Authorities in implementing the aerodrome emergency plan;~~
 - ~~(3) coordination of aerodrome emergency exercises;~~
- ~~provision of rescue and fire fighting services, organisation, staffing, training and periodic checking; the accountable manager may be:~~
- ~~(4) revision of aerodrome emergency plan; and~~
 - ~~(5) provisions for disabled aircraft removal.~~

~~WILDLIFE MANAGEMENT~~

- ~~(a) The wildlife management may include, but not limited to:~~
- ~~(1) establishment of a wildlife risk management programme;~~
 - ~~(2) planning and Organisation of wildlife control measures according to the wildlife risk management programme;~~
 - ~~(3) reviewing wildlife strike reports, daily wildlife activity records and maintenance reports, to determine the requirement for short or long term control measures; and~~
 - ~~(4) ensure supply, safe keeping and correct maintenance of wildlife control equipment and consumables.~~

~~TRAINING MANAGEMENT~~

- ~~(a) The training management may include, but not limited to:~~
- ~~(1) establishment of training needs analysis for personnel involved in aerodrome operations, maintenance and rescue and fire fighting;~~
 - ~~(2) establishment of an effective training programme;~~
 - ~~(3) coordination of personnel training programme; and~~

~~(4) maintenance of personnel training records;~~

~~MAINTENANCE MANAGEMENT~~

~~(a) The maintenance management may include, but not limited to:~~

~~(a) establishment of a maintenance programme for the chief executive officer (CEO);~~

~~(b) the chief operating officer (COO);~~

~~(1) the aerodrome infrastructure;~~

~~(a)(c) monitoring chairperson of the implementation of the maintenance programme; and board of directors;~~

~~(2) provision of resources for ad hoc repairs.~~

~~QUALITY AND SECURITY MANAGEMENT FOR AERONAUTICAL DATA AND AERONAUTICAL INFORMATION PROVISION ACTIVITIES~~

~~(d) establishing and maintaining a partner; or~~

~~(e) the quality and security proprietor.~~

~~The appointment of an accountable manager who is given the required authorities and responsibilities, requires that the individual has the necessary attributes to fulfil the role. The accountable manager may have more than one function in the organisation. Nonetheless, the accountable manager's role is to instil safety as a core organisational value, and to ensure that the safety management with regard to aeronautical data system is properly implemented and aeronautical information maintained through the allocation of resources and tasks.~~

~~establishing and maintaining arrangements with third parties involved in the provision of required services.~~

AMC1- ADR.OR.D.015(b) – Personnel requirements

~~COMPLIANCE MONITORING~~

~~(a) To ensure that the aerodrome operator continues to meet the requirements of this Part and other applicable Parts, the accountable manager should identify and nominate a compliance monitoring manager whose role is to verify, by monitoring the activities of the aerodrome, that the standards required by Part-OR and other applicable parts, and any additional requirements as established by the aerodrome operator, are being carried out properly under the supervision of the relevant head of each functional area of the organisation; if more than one person is nominated, then there should be clearly defined responsibilities and one person should be the focal point and have the overall responsibilities of the compliance monitoring manager.~~

~~(b) The compliance monitoring manager should be responsible for ensuring that the compliance monitoring programme is properly established, implemented, maintained and continually reviewed and improved;~~

~~(c) The compliance monitoring manager should:~~

~~(2) have direct access to the accountable manager;~~

~~(3) in the fulfilment of its role be independent of line management;~~

~~NOMINATED PERSONS~~

~~(a) General~~

- (1) A description of the functions of the nominated persons, including their names, as well as clearly defined responsibilities and authorisations, should be contained in the aerodrome manual. Nominated persons should have adequate resources available to perform their duties.
- (2) The aerodrome operator should make arrangements to ensure adequate continuity of supervision in the absence of nominated persons.
- (3) The person nominated by the aerodrome operator should not be nominated by another aerodrome operator, unless agreed with the Competent Authority.
- (4) Persons nominated should be foreseen to work sufficient hours to fulfil the management functions associated with the scale and complexity of the operation.
- (5) A nominated person may hold more than one of the nominated posts if such an arrangement is considered suitable and properly matched to the aerodrome operator's organisation, and the complexity of its operations.

(b) Competence of nominated persons

- (4) The manager of Operational Services and the Maintenance ~~have access to all parts of the organisation, and as necessary, any contracted organisation.~~

~~The compliance monitoring~~ manager should have:

- (1) adequate practical experience and expertise in aerodrome operations or maintenance (or similar area) respectively;
- (2) adequate ~~comprehensive~~ knowledge of the applicable requirements in the area of aerodromes;
- ~~(2)~~(3) appropriate level of knowledge of safety and quality assurance principles and management; and
- ~~(3)~~(4) knowledge of the aerodrome manual;
- ~~(2)~~(5) ~~comprehensive knowledge of the applicable requirements in the area of aerodrome.~~

GM1- ADR.OR.D.015(b) Personnel requirements

COMBINATION OF NOMINATED PERSONS RESPONSIBILITIES

- (b) The acceptability of a single person holding more than one post, possibly in combination with being the accountable manager, should depend upon the aerodrome operator's organisation, and the complexity of its operations. The two main areas of concern should be competence, and an individual's capacity to meet his/her responsibilities.
- (c) As regards competence in different areas of responsibility, there should not be any difference from the requirements applicable to persons holding only one post.
- ~~(b)~~(d) The capacity of an individual to meet his/her responsibilities should primarily be dependent upon the complexity of the aerodrome operator's organisation and its operations. However, the complexity of the aerodrome operator's organisation, or of its operation may prevent, or limit, combinations of posts.

AMC1- ADR.OR.D.015(c) Personnel requirements

COMPLIANCE MONITORING

- (1) ~~Depending on the size of the organisation and the type and complexity of operations, the compliance monitoring function may be exercised by the accountable manager or other independent means.~~

~~AMC1-ADR.OR.D.015(c) – Personnel requirements~~

SAFETY MANAGEMENT MANAGER

- (a) The safety manager should be the focal point and responsible for the development, administration, and maintenance of an effective safety management system. ~~If more than one person is nominated to the safety management function, then there should be clearly defined responsibilities and one person should be the focal point and have the overall responsibilities of the safety manager. (see also AMC1-ADR.OR.D.005(b)(1)).~~
- (b) The role of the safety manager should be to:
 - (1) facilitate hazard identification, risk analysis, and management;
 - (2) monitor the implementation and functioning of the safety management system, including the necessary safety actions;
 - (3) manage the safety reporting system of the aerodrome;
 - (4) provide periodic reports on safety performance;
 - (5) ensure maintenance of safety management documentation;
 - (6) ensure that there is safety management training available, and that it meets acceptable standards;
 - (7) provide advice on safety matters; and
 - (8) initiate and participate in internal occurrence/accident investigations.
- (c) The safety manager should have:
 - (1) adequate practical experience and expertise in aerodrome operations, or maintenance, or similar area;
 - (2) adequate knowledge of safety and quality management;
 - ~~(3) adequate knowledge of the aerodrome manual;~~
 - ~~(4) comprehensive knowledge of the applicable requirements in the area of aerodrome.~~
- ~~(d) The safety management function should normally belong to the Safety Services Office.~~

~~GM1-ADR.OR.D.015(c) – Personnel requirements~~

SAFETY MANAGEMENT

~~In the case of small organisations where combination of responsibilities may prevent sufficient independence in this regard, the arrangement for safety assurance may be supplemented by additional independent means.~~

~~AMC1-ADR.OR.D.015(d) – Personnel requirements~~

AERODROME MANAGER

The aerodrome manager should have:

- ~~(1)(3)~~ clearly defined responsibilities, authorisations and resources available for the management and coordination of the day to day operation of the aerodrome, in accordance with the applicable requirements and the aerodrome manual;
- ~~(4)~~ adequate practical experience and expertise in aerodrome operations or maintenance or similar area;
- ~~(2)(4)~~ comprehensive knowledge of the applicable requirements in the area of aerodromes;
- ~~(5)~~ appropriate level of knowledge of safety and quality management; and
- ~~(6)~~ knowledge of the aerodrome manual.

(d) The safety manager should not be one of the persons referred to in ADR.OR.D.015(b) or AMC2 ADR.OR.D.005(b)(11). However, in the case of less complex aerodrome organisations/operations, the safety manager may be the accountable manager, or one of the persons referred to in ADR.OR.D.015(b), or AMC2 ADR.OR.D.005(b)(11), or any other person at appropriate management level, provided that he/she can act independently of other managers within the organisation of the aerodrome operator, and has direct access to the accountable manager and to appropriate management for safety matters.

AMC1-ADR.OR.D.015(e)-d) Personnel requirements

DETERMINATION OF PERSONNEL NEEDS AND QUALIFICATIONS

- (a) The aerodrome operator should determine the required personnel for the planned tasks in accordance with AMC1-ADR.OR.B.015 (b)(4).
- (b) The aerodrome operator should determine the required personnel qualifications, in accordance with the applicable requirements (and the national and European Union legislation where ~~this is~~ applicable), and include them in the aerodrome manual. A documented system with defined responsibilities should be in place, in order to identify any needs for changes with regard to personnel qualifications.

GM1-ADR. OR.D.015 AR-200(e)-(d) Personnel requirements

QUALIFICATION OF PERSONNEL

The term qualification 'qualified' denotes fitness for the purpose. This may be achieved through fulfilment of the necessary conditions such as completion of required training, or acquisition of a diploma or degree:

Qualification could also be interpreted to mean, or through the gaining of suitable experience. It, also, includes the ability, capacity, knowledge, or skill that matches or suits an occasion, or makes someone eligible for a duty, office, position, privilege, or status. ~~Qualification does not necessarily imply competence.~~

Certain posts may, by nature, be associated with the possession of certain qualifications in a specific field (e.g. rescue and ~~fire-fighting~~ firefighting, civil, mechanical or electrical engineering, wildlife biology, etc.). In such cases, the person occupying such a post is expected to possess the necessary qualifications at a level that is in accordance with the applicable national or European Union legislation.

AMC1- ADR.OR.D.015(f) — Personnel requirements

~~PERSONNEL RECORDS~~

- ~~(a) The aerodrome operator should have **017(a)** system in place to record the following information for each person:~~
- ~~(1) personnel previous working experience;~~
 - ~~(2) competency checks, including language proficiency as appropriate;~~
 - ~~(3) training.~~
- ~~(a) Latest changes should be reflected into personnel records.~~
- ~~(b) Personnel records should be kept, as long as they are employed by the aerodrome operator.~~

GM1- ADR.OR.D.015(f) — Personnel requirements

~~TRAINING RECORDS~~

~~The training records maintained for each individual should include as a minimum:~~

- ~~(1) the name of the trainee;~~
 - ~~(2) the date(s) and the duration of the training;~~
 - ~~(3) the place where the training was received;~~
 - ~~(4) the name of the organisation that provided the training;~~
- ~~(5) the subjects covered and the methodology of the course;~~
- ~~(6) any comments made by the instructor, if applicable;~~
- ~~(7) the performance evaluation of the trainee, if applicable;~~
- ~~(8) the name of the instructor; and~~
- ~~(a) the signature of the individual that received the training.~~

AMC1- ADR.OR.D.015(k) — Personnel requirements

~~DISTRIBUTION OF RULES AND PROCEDURES~~

- ~~(a) The aerodrome operator should have a system in place to distribute the rules and procedures to personnel to exercise their duties.~~
- ~~(b) The aerodrome operator should run competency checks, prescribed in the aerodrome manual, to verify that personnel are aware of the rules and procedures relevant to their duties.~~

GM1- ADR.OR.D.015(g) — Personnel requirements

~~DISTRIBUTION MEANS OF RULES AND PROCEDURES~~

~~The aerodrome operator may use electronic means or conventional means to distribute rules and procedures to personnel. The method used should verify that the information reached the intended recipient.~~

~~AMC1-ADR.OR.D.015(g)~~ Personnel Requirements

TRAINING PROGRAMME – GENERAL

~~(a)~~ The training programme should cover all personnel:

- ~~(1)~~ involved in the operation, rescue and firefighting, maintenance, and management of the aerodrome ~~and (supervisors, managers, senior managers, and the accountable manager); and~~
- ~~(2)~~ those persons operating unescorted on the movement area, and other operational areas of the aerodrome, related to other organisations which operate or provide services at the aerodrome,

~~_____~~ regardless of their level in the organisation.

~~(b)~~ The training of persons mentioned in paragraph (a) should be completed prior to the initial performance of their duties, or allowing them unescorted access on the movement area and other operational areas of the aerodrome, as appropriate.

~~(c)~~ The training programme should include safety management system training whose level of detail should be appropriate to the individual's responsibility and involvement in the safety management system; for persons referred to in paragraph (a)(1), it should also include human and organisational factors; for those persons referred to in paragraph under (a)(2) employed by other organisations operating, or providing services at the aerodrome, the safety management system training may cover only the necessary elements (e.g. relevant procedures, safety reporting system, aerodrome safety programmes, etc.).

~~(a)(d)~~ The training programme should consist of the following:

- ~~(3)~~ a ~~documented process, included in the aerodrome manual,~~ to identify training ~~requirements standards, including syllabi, and frequency for each type of training and area of activity for the persons mentioned in paragraph (a), including for instructors and assessors,~~ and track completion of required training;
- ~~(4)~~ a validation process that measures the effectiveness of training;
- ~~(5)~~ initial job-specific training;
- ~~(6)~~ ~~a documented validation process that measures the effectiveness of training;~~
- ~~(7)~~ ~~initial training;~~
- ~~(8)(6)~~ ~~on the on-the-job training; and~~
- ~~(9)(7)~~ ~~recurrent training.~~

~~(b)~~ ~~Training frequencies, contents, syllabi and checking programmes should comply with the requirements prescribed in Part ADR.OPS.~~

~~(e)(e)~~ The training programme should identify training programme should responsibilities and contain procedures:

- ~~(1)~~ for training and checking of the trainees;
- ~~(2)~~ to be applied in the event that personnel do not achieve or maintain the required standards.

~~(f)~~ Training contents and syllabi should comply with the requirements prescribed in Part-ADR.OPS.

- ~~(d)~~(g) A training file should be developed for each employee, including management, to assist in identifying and tracking employee training requirements, and verifying that personnel have received the planned training.
- ~~(e)~~ The aerodrome operator should specify information related to paragraphs (d) and (e), including the identified training standards for initial, on-the-job, and recurrent training, including training responsibilities, contents, and the related syllabi, and frequency, validation and training records management, of the persons referred to in paragraph (a).
- ~~(f)~~(h) The information provided in paragraph (d), (e) and (f) above should be included in the aerodrome manual.

AMC2-GM1 ADR.OR.D.015(g)–017(a) Personnel requirements

TRAINING PROGRAMME – RECURRENT, REFRESHER, AND DIFFERENCES TRAINING

(a) Recurrent training

- (1) The initial training programme should be valid for a period not exceeding 12 months. Thereafter, the aerodrome operator should ensure that the persons mentioned under paragraph (a) of AMC1 ADR.OR.D.017(a) complete recurrent training at intervals not exceeding 12 months since the initial completion of their training programme.
- (2) If the recurrent training is undertaken within the last 3 calendar months of the 12-month period, the new validity period should be counted from the original expiry date.

(b) Refresher training

When a person mentioned under paragraph (a) of AMC1 ADR.OR.D.017(a) has not performed any duties for a significant period before the expiry date of its initial training programme, or its last recurrent training (as the case may be), the aerodrome operator should ensure that that person completes a relevant refresher training prior to:

- (1) being assigned duties; or
- (2) being allowed unescorted access on the movement area and other operational areas of the aerodrome, as appropriate.

(c) Differences training – same aerodrome operator

The aerodrome operator should ensure that personnel mentioned under paragraph (a)(1) of AMC1 ADR.OR.D.017(a) who have already completed the necessary training programme, and are to be assigned to different duties, complete an appropriate training which covers any differences between their previous and future duties. The differences training should be determined, as necessary, on the basis of a comparison of the required training programme with the training programme already completed by the relevant personnel, taking into account the personnel's previous training as documented in his/her training records.

(d) Differences training – other aerodrome operator

When a person mentioned under paragraph (a)(1) of AMC1 ADR.OR.D.017(a) who has already completed the necessary training programme, is employed by another aerodrome operator, the latter may establish a differences training for that person to complete. Such a differences training should be determined, as necessary, on the basis of a comparison of the training already completed by the relevant person, (taking into account its previous training as documented in his/her training records) with the training

programme that is required for the post that the person will cover. In any case, such a differences programme should not give credit for training areas which are aerodrome specific.

AMC2 ADR.OR.D.017(a) Personnel requirements

TRAINING PROGRAMME – CHECKING OF TRAINEES

- (a) Checking required for each training course should be accomplished by the method appropriate to the training element to be checked.
- (b) Training elements that require individual practical participation may be combined with practical checks.

GM2 ADR.OR.D.017(a) Personnel requirements

TRAINING PROGRAMME – CHECKING OF TRAINEES

The methods to be used for the checking of the trainees could include:

- (a) practical demonstration,
 - (b) computer-based assessment,
 - (c) oral or written tests,
- or combinations of such methods, as appropriate.

AMC1 ADR.OR.D.017(b) Personnel requirements

INSTRUCTORS – ASSESSORS

- (a) The aerodrome operator should nominate instructors and assessors to be used for the implementation of the training and proficiency check programmes. The personnel to be nominated may also include contracted instructors for individual subjects. The aerodrome operator may also nominate personnel proposed by organisations operating or providing services at the aerodrome to be used as instructors and assessors for the implementation of the respective part of the training and proficiency check programmes of these organisations' personnel. In any case, the responsibility to ensure the proper implementation of the programme is with the aerodrome operator.
- (b) A person may be qualified and nominated both as an instructor and as an assessor by the aerodrome operator. However, such a person may not provide assessment for own instruction, courses, or material.
- (c) Instructors
 - (1) Theoretical instruction ~~shall~~should be given by appropriately qualified instructors. They should have:
 - (i) appropriate level and depth of knowledge in the field where instruction is to be given;
 - (ii) documented ability to use appropriate instructional techniques; and
 - (iii) ~~at least 2 years of adequate~~ experience in the ~~field~~subject where instruction is to be given.
 - (2) Instruction on practical skills ~~shall~~should be given by appropriately qualified

instructors, who ~~have the following qualifications:~~

- (i) meet the theoretical knowledge, and the working experience requirements appropriate to the instruction being given;
- (ii) have demonstrated the ability to instruct, and to use appropriate instructional techniques;
- (iii) ~~have practiced~~ are proficient in instructional techniques in the areas in which it is intended to provide instruction; and
- (iv) receive regular refresher training to ensure that the instructional competences are maintained.

(d) Assessors

The persons who are responsible for assessing the competence and skills of the personnel should:

- (1) have demonstrated the ability to assess the performance of, and conduct tests and checks in the areas covered by the training;
- (2) ~~(ii)~~ receive regular refresher training to ensure that the assessment standards are maintained up to date; and
- (3) meet the theoretical knowledge requirements appropriate to the instruction being given and have ~~at least 2 years of adequate~~ working experience in the area of instruction.

AMC1 ADR.OR.D.017(c)(1) Personnel requirements

DISTRIBUTION OF RULES AND PROCEDURES

- ~~(e)(b) The aerodrome operator should have a system in place to distribute the rules and procedures to personnel to exercise their duties.~~
- (c) Proficiency checks should verify that personnel are aware of the rules and procedures relevant to their duties.

GM1 ADR.OR.D.015(c)(1) Personnel requirements

DISTRIBUTION MEANS OF RULES AND PROCEDURES

The aerodrome operator may use electronic means, or conventional means to distribute rules and procedures to personnel. The method used should verify that the information reached the intended recipient.

GM1 ADR.OR.D.017(c)(3) Personnel requirements

PROFICIENCY CHECKS

- (a) Proficiency checks should be conducted by nominated assessors in accordance with AMC1 ADR.OR.D.017(b).
- (b) The maximum interval between two proficiency checks should not exceed:
- (1) 12 calendar months for rescue and firefighting personnel; and
 - (2) 24 months for all other personnel.

The first proficiency check should be completed within:

- (1) the first year since the completion of the initial training programme, for rescue and firefighting personnel;
 - (2) two years since the completion of the initial training programme, for all other personnel.
- (c) The proficiency check programme should include a validation process that measures the effectiveness of the programme.
- (d) The proficiency check programme should identify checking responsibilities and relevant checking methods, including procedures to be applied in the event that personnel do not achieve the required standards.
- (e) Information related to the proficiency check programme should be included in the aerodrome manual.

GM2 ADR.OR.D.017(c)(3) Personnel requirements

PROFICIENCY CHECKS

The purpose of the proficiency check is to establish the ability of an individual to perform satisfactorily, in accordance with applicable requirements and the content of the aerodrome manual. To this end, the elements that each proficiency check should cover should be identified.

A proficiency check does not need to cover all associated elements at the same time; however, all elements of a proficiency check should be covered within the period specified in GM1 ADR.OR.D.017(c)(3).

The person(s) to be checked should be aware about the relevant procedure.

Proficiency checks may be conducted during normal and/or abnormal/emergency conditions depending on the situation and the specialty of the person being checked.

AMC1 ADR.OR.D.017(d) Personnel requirements

PERSONNEL RECORDS

(b) The aerodrome operator should use its record keeping system (see AMC1 ADR.OR.D.035) to record the following information for each person:

- (1) starting date of employment/ending date of employment (if applicable);
- (2) area of activity;
- (3) previous working experience;
- (4) qualifications;
- (5) training (before entry and subsequent); and
- (6) proficiency checks, including language proficiency as appropriate;

~~(b)~~(c) Latest changes should be reflected into personnel records.

GM1 ADR.OR.D.017(d) Personnel requirements

TRAINING RECORDS

(a) Training programme — general

The aerodrome operator should maintain records of the training sessions that it has provided, including as a minimum the following:

- (1) area of training and subjects covered;
- (2) names of participants;
- (3) date and duration of training; and
- (4) name of the instructor.

(b) Training records of individuals

The training records maintained for each individual should include as a minimum:

- ~~(9)~~(5) the name of the trainee;
- ~~(10)~~(6) the date(s) and the duration of the training;
- ~~(11)~~(7) the place where the training was received;
- ~~(12)~~(8) the name of the organisation that provided the training;
- (9) the subjects covered, and the methodology of the course;
- (10) any comments made by the instructor if applicable;
- (11) the performance evaluation of the trainee if applicable; and

(12) the name and signature of the instructor.

GM2 ADR.OR.D.017(d) Personnel requirements

PROFFICIENCY CHECK RECORDS

The proficiency check records maintained for each individual should include as a minimum:

- (a) the name of the person checked;
- (b) the date(s) and the duration of the proficiency check;
- (c) the methodology of the check conducted;
- (d) any comments made by the assessor;
- (e) the performance evaluation of the person checked; and
- (f) the name and signature of the assessor.

GM1 ADR.OR.D.020(a) Facilities requirements

FACILITIES TO BE PROVIDED

Facilities should be provided to allow the performance of all tasks and activities in accordance with the applicable requirements. This includes, but is not limited to:

- (b) adequate offices, working space, and office equipment;
- (c) personnel protective equipment;
- (d) equipment necessary for inspecting the aerodrome and its facilities, such as clinometers, distance measurement devices, etc.; and
- (b)(e) access to data sources necessary for the development and effective functioning of the safety management system and compliance monitoring of the aerodrome.

AMC1- ADR.OR.D.020(b) Facilities requirements

Designated areas may vary and include facilities such as cargo areas, or even open-air areas.
Aircraft stands should also be designated for aircrafts that carry dangerous goods.

GM1 ADR.OR.D.025(a) – Coordination with other ~~relevant~~ organisations

COORDINATION OF SAFETY PROCEDURES

Coordination and interface with the safety procedures of other relevant organisations that are active at the aerodrome include, but is not limited to the following: aircraft operators, air navigation service providers, providers of apron management services, ground handling service providers, providers of services to persons with reduced mobility, aircraft maintenance organisations, flying training organisations, public authorities that operate on the movement area—etc, as well as other organisations that perform activities independently at the aerodrome.

AMC2-GM2 ADR.OR.D.025(b) – Coordination with other ~~relevant~~ organisations

COMPLIANCE OF OTHER ORGANISATIONS

In order to ensure compliance of the organisations operating or providing services at the aerodrome, with the requirements of Regulation (EC) No 216/2008 and its Implementing Rules that are applicable to aerodromes and their operators, as well as with the content of the aerodrome manual, the aerodrome operator should:

- (a) conduct audits and inspections of such organisations through its compliance monitoring ; and
- (b) establish procedures for the monitoring of related activities at the aerodrome.

AMC1 ADR.OR.D.027 Safety programmes

SAFETY PROGRAMMES – AERODROME SAFETY COMMITTEES

- (a) The aerodrome operator should:
 - (1) organise, coordinate and implement programmes to promote safety at the aerodrome. Such programmes include, but are not limited to:
 - (i) runway safety;
 - (ii) apron safety; and
 - (iii) FOD prevention;
 - (2) coordinate and promote the exchange of information, and the joint investigation of occurrences, serious incidents, and accidents.
- (b) The aerodrome operator should establish, coordinate, and lead local safety committees, including a Local Runway Safety Team, dealing in particular with runway safety, apron safety, and the safety of the operations on the movement area and at the aerodrome in general. All relevant organisations operating or providing services at the aerodrome should participate to such safety committees.

~~**AMC3 ADR.OR.D.025(c) Coordination with other relevant organisations**~~ The local safety committees should convene regularly, identify and review local safety issues, and examine possible solutions, and need for action. Minutes of such meetings should be kept. Procedures relevant to the functioning of local safety committees should be included in the aerodrome manual.

AMC2 ADR.OR.D.027 Safety programmes

HOT SPOTS

Once hot spots have been identified at an aerodrome, suitable strategies should be implemented to remove the hazard and, when this is not immediately possible, to manage and mitigate the risk, including the publication of HOT SPOT charts in the Aeronautical Information Publication.

GM1 ADR.OR.D.027 Safety programmes

~~COMPLIANCE OF OTHER ORGANISATIONS~~

~~In order to ensure compliance of the organisations operating or providing services at the aerodrome, with the regulatory requirements and with the content of aerodrome manual, the aerodrome operator should conduct audits and inspections of such organisations, through its compliance monitoring function (see AMC3-ADR.OR.D.005 (d)).~~

~~GM1-ADR.OR.D.025~~ **Coordination with other relevant organisations**

AERODROME SAFETY COMMITTEES

(a) Manoeuvring area/Apron Safety Committee

- (1) The aerodrome operator should establish ~~an (a) Manoeuvring area/Apron Safety Committee;(s);~~
- (2) The Manoeuvring area/Apron Safety Committee ~~has(s) should have~~ an advisory role to the aerodrome operator;
~~(a) Management;~~

~~(b)~~ The of Manoeuvring area /Apron Safety Committee(s)

- (1) ~~The Manoeuvring area /Apron Safety Committee(s)~~ should be chaired by an ~~Aerodrome Operator's Official~~aerodrome operator's official, responsible for aerodrome operations; and
- (2) The ~~Safety Manager~~aerodrome operator's safety manager should act as the secretary of the Committee~~;(s).~~

~~(b)~~(c) Composition of Manoeuvring area /Apron Safety Committee(s)

Participation ~~includes~~should include, but ~~is~~ not limited to representatives of:

- ~~(1)~~ aerodrome users active in flight operations~~and/or;~~
- ~~(1)~~(2) aircraft ground handling services providers;
- ~~(2)~~(3) aerodrome rescue and fire-fighting services;
- ~~(3)~~(4) aerodrome operations;
- ~~(4)~~(5) aerodrome wildlife management;
- ~~(5)~~(6) aerodrome maintenance; and
- ~~(6)~~(7) air navigation service provider(s).

~~(e)~~(d) Tasks:

~~To~~The tasks of the Manoeuvring area /Apron Safety Committee(s) should be:

- (1) to receive and evaluate reports on operational safety issues;
 - (2) ~~To~~to receive reports and statistical information on accidents and incidents, and propose solutions;
 - (3) ~~To~~to advise on movement area/apron safety issues ~~such as~~;
- ~~(b)~~ The Apron Safety Committed should convene at regular intervals.
- (i) Local Runway promotion of apron safety discipline;
 - (ii) FOD prevention;
 - (iii) developing measures for safety operations;
 - (iv) considering actions to resolve movement area safety problems;

- (v) apron equipment issues;
- (vi) adherence to vehicle traffic issues;
- (vii) new and/or updated safety instructions;
- (viii) personal protective clothing/equipment issues;
- (ix) methods to develop and promote apron safety awareness initiatives,
- (x) snow and ice clearance issues;
- (xi) proposed aerodrome works;
- (xii) proposed changes/developments to the movement area;
- (xiii) standard operating procedures, etc.

GM2 ADR.OR.D.027 Safety Team programmes

The LOCAL RUNWAY SAFETY TEAM

(a) Context

As part of its runway safety programme, the aerodrome operator should establish and lead a Local Runway Safety Team and act on local runway safety issues, including runway incursion prevention.

(a) Composition

A runway incursion is defined as 'Any occurrence at an aerodrome involving the incorrect presence of an aircraft, vehicle, or person on the protected area of a surface designated for the landing and take-off of aircraft.'

(b) Local Runway Safety Team composition

Participation ~~includes~~ should include representatives from all interested parties with direct involvement in runway operations at the aerodrome, including, but is not limited, to:

- (1) aerodrome operations;
- (2) aerodrome engineering and maintenance;
- ~~(2)~~(3) air navigation service providers;
- ~~(3)~~(4) aircraft operators that operate of the Aerodrome aerodrome;
- ~~(4)~~(5) airport aerodrome rescue and fire-fighting firefighting services;
- (6) drivers having access on the manoeuvring area.

(a)(c) Role

The role of the Local Runway Safety Team should be to advise the appropriate ~~Management~~ management on potential runway safety issues, and to recommend mitigating measures.

(d) Tasks

The Local Runway Safety Team may have the following tasks:

- ~~(5) Identification~~ identification of potential runway safety issues;
- (1) ~~Develop, including the need for establishment of hot spots or other problem areas at the aerodrome and run local awareness campaigns~~ the review of the relevant entries of the AIP;
- (2) Assisting developing and running local awareness campaigns that focus on local issues, for example, producing and distributing local hot spot maps, or other guidance material considered as necessary;
- ~~(2)~~(3) assisting in verifying that communications between air traffic controllers, or other Air Traffic Controllers, Pilots and Vehicle Drivers Services personnel, pilots, and vehicle drivers are satisfactory; ~~and~~
- ~~(3)~~(4) Making observations on a regular basis in different weather and light conditions to assess whether all markings and signage visual aids are adequate and understandable by all parties; concerned, or identify potential aerodrome design issues;

- (5) understanding the operating difficulties of personnel working in other areas, and recommending areas for improvement;
- (6) development of joint training programmes on runway incursion prevention; and
- (7) provide advice prior to the implementation of changes to the aerodrome to identify potential for runway incursion.

GM3-ADR.OR.D.025 — Coordination with other relevant organisations-027 Safety programmes

HOT SPOTS

A hot spot is defined as 'a location on an aerodrome movement area with a history, or potential risk of collision, or runway incursion, and where heightened attention by pilots/drivers is necessary.'

Strategies to manage and mitigate the risk from hot spots, depending on the case, may include, but are not limited to:

- (a) awareness campaigns;
- (b) additional visual aids (signs, markings, and lighting);
- (c) establishment of alternative routings;
- (d) introducing changes to the design of parts of the aerodrome; and
- (e) the mitigation of blind spots in the aerodrome control tower.

Aerodrome charts showing hot spots should be produced locally, checked regularly for accuracy, revised as needed, distributed locally, and published in the AIP. The criteria used to establish and chart a hot spot are contained in the PANS-ATM (Chapter 7) and Annex 4 — Aeronautical Charts (Chapters 13, 14 and 15).

Examples of how hot spots are shown on charts are provided in Figures 1, 2, and 3 below.

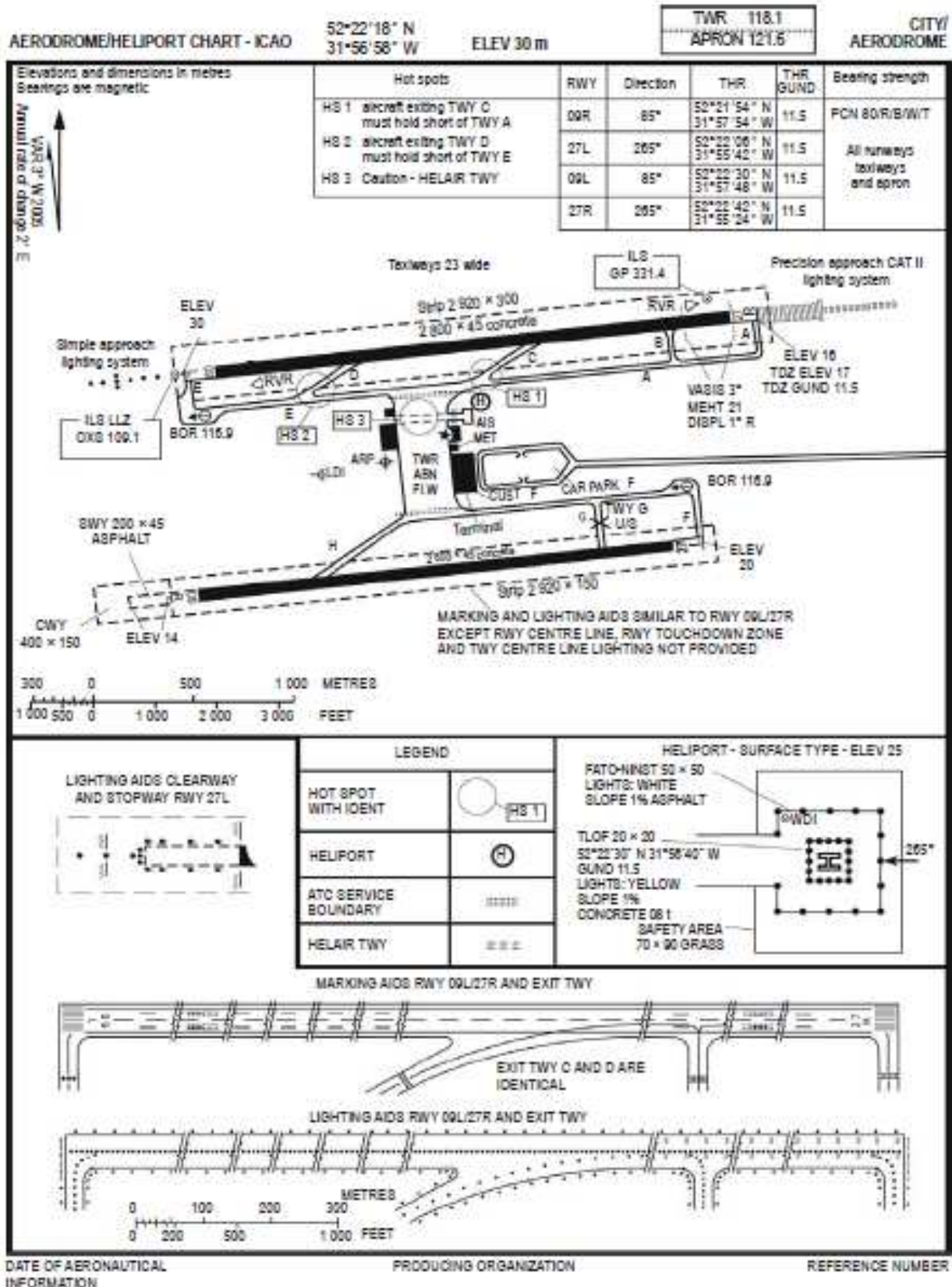

Figure 1

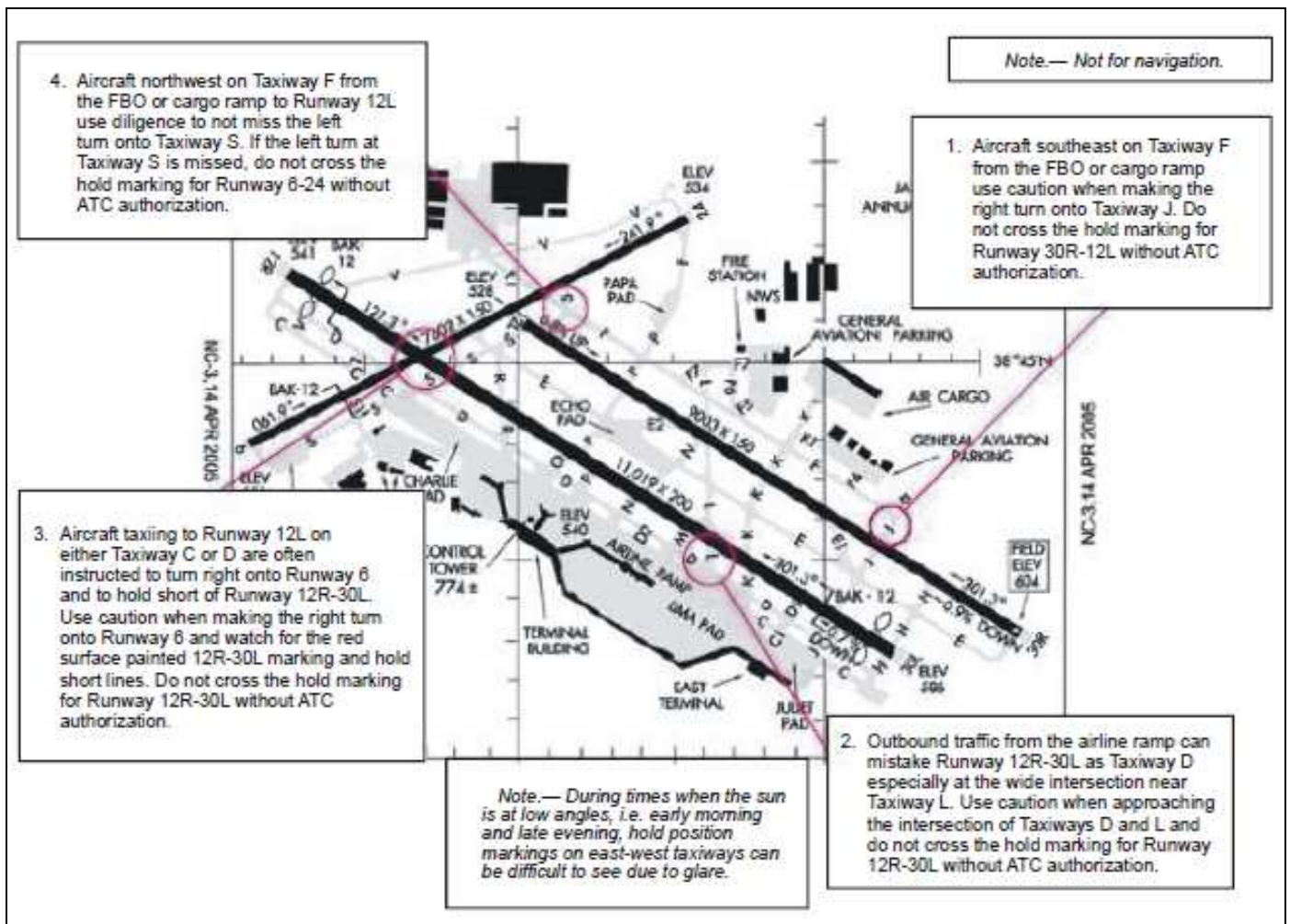

Figure 2

OTHER ACTIVITIES

The certification of an aerodrome is based upon aviation activities that are required to use a certified aerodrome. However, many other activities take place on an aerodrome that do not require the aerodrome to be certified such as private flights, flying training, gliding, ground handling etc. The effect of these activities on those operations requiring the use of a certificated aerodrome should be considered by the aerodrome operator, with the aim of mitigating these risks wherever practicable. There should be actions of sharing the risks and agreeing the mitigation with all relevant aerodrome users to encourage integrated safety management and closer cooperation among all stakeholders.

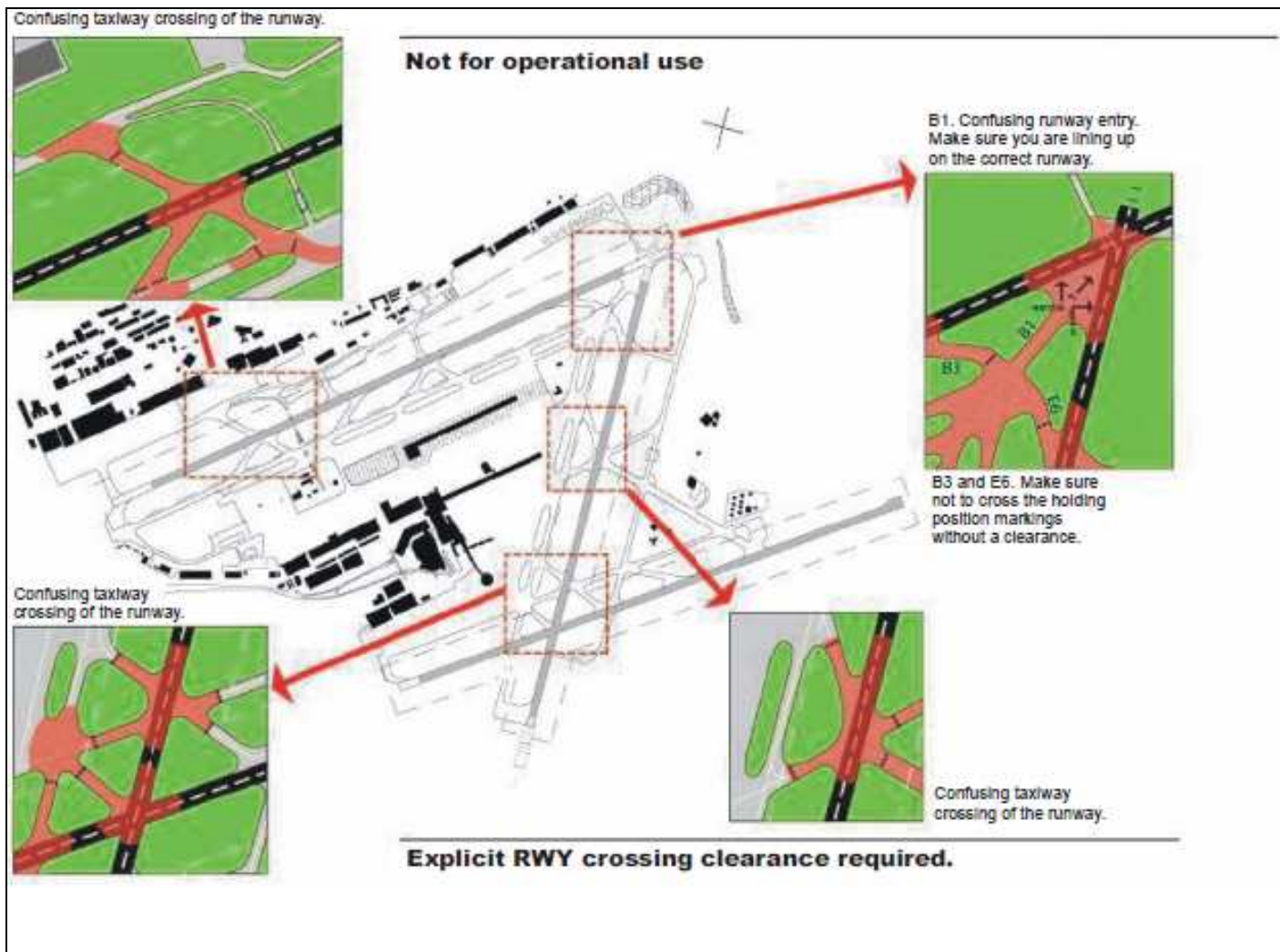

Figure 3

AMC1-ADR.OR.D.030(a) – Safety reporting system

SAFETY REPORTING SYSTEM

(a) Safety reporting system – General

- (1) An effective ~~occurrences~~safety reporting system should include, apart from aerodrome operator's personnel, aircraft operators, ground handling service providers, air navigation service providers, and any other organisation operating on the aerodrome, or providing services at the aerodrome.
- (2) The safety reporting system should include voluntary reporting possibilities intended for safety hazards identified by the reporter, and that may have potential safety consequences.
- (3) The aerodrome operator should identify which ~~occurrences~~events are mandatory to be reported.
- (4) The aerodrome operator should provide the means and the format for ~~the occurrence~~reporting, which should be such that meets the existing reporting requirements foreseen in the applicable legislation in terms of time, format, and required information to be reported.
- (5) The ~~occurrences~~safety reporting system should include an acknowledgement to the reporter for the submission of the report.
- (6) The reporting process should be as simple as possible, and well documented, including details as to what, how, where, whom, and when to report;
- (7) Regardless of the source or method of submission, once the information is received, it should be stored in a manner suitable for easy retrieval and analysis;
- (8) Access to the submitted reports should be restricted to persons responsible for storing and analysing them;
- (9) Protection of the identity of the reporter should be ensured. ~~This should be achieved by not recording any identifying information of the occurrence; and, and the procedures established by the aerodrome operator to gather additional information for analyses, or investigations should respect this principle;~~
- (10) ~~Occurrence~~The safety reporting system should include a feedback system to the reporting person, on the outcome of the occurrence analysis.

Wildlife hazard

~~(a)(b) GM1-ADR.OR.D.030(a);(c);(d) – Safety reporting system~~

~~NEED FOR OCCURRENCE REPORTING~~

- ~~(a) – The overall purpose of the occurrence reporting system is to use reported information to improve the level of safety performance of the aerodrome and not to attribute blame.~~
- ~~(b) – The objectives of the occurrence reporting system should be:
 - ~~(1) – to enable an assessment to be made of the safety implications of each relevant incident and accident, including previous similar occurrences, so that any necessary action can be initiated; and~~
 - ~~(2) – to ensure that knowledge of relevant incidents and accidents is disseminated, so that other persons and organisations may learn from them.~~~~

~~AMC2-ADR.OR.D.030(b);(c) — Safety reporting system~~

~~WILDLIFE MANAGEMENT REPORTING~~

- (1) The aerodrome operator should ensure that ~~the~~its safety reporting system specifically addresses the requirement for all third parties (aircraft operators, aircraft mechanics, air traffic controllers, and other Air Traffic Services personnel, etc.) and all aerodrome personnel, to ~~submit reports~~report to the aerodrome operator related to wildlife strikes, and relevant identified hazards ~~to the aerodrome operator~~.
- (2) The reporting of such third parties should be done irrespectively of any other requirements according to which they have to report to the ~~competent authority~~Competent Authority of the aerodrome, or the state of registry of the aircraft involved, or any other ~~competent authority~~Competent Authority in the context of the national occurrence reporting programme.

GM1 ADR.OR.D.030(a):(c):(d) Safety reporting system

NEED FOR SAFETYREPORTING

- (a) The overall purpose of the safety reporting system is to use reported information to improve the level of safety performance of the aerodrome, and not to attribute blame.
- (b) The objectives of the safety reporting system should be:
- (1) to enable an assessment to be made of the safety implications of each relevant occurrence, serious incident and accident, including previous similar events, so that any necessary action can be initiated; and
 - (2) to ensure that knowledge of relevant occurrences, serious incidents and accidents is disseminated, so that other persons and organisations may learn from them.

AMC1- ADR.OR.D.035 – Record keeping

DOCUMENTATION TO BE RETAINED

- (a) The system employed by the aerodrome operator for record-keeping should provide for adequate procedures, storage facilities, and reliable traceability of the records related to the activities of the aerodrome operator that are subject to the Basic Regulation and its Implementing Rules.
- (b) Records should be kept in paper form, or in electronic format, or a combination of both. Records stored on microfilm or optical disc format are also acceptable. The records should remain legible throughout the required retention period. The retention period starts when the record has been created or last amended.
- (c) Paper systems should use robust material which can withstand normal handling and filing.
- (d) Computer systems should have at least one backup system which should be updated within 24 hours of any new entry. Computer systems should include safeguards against the ability of unauthorised personnel to alter the data.
- (e) All computer hardware used to ensure data backup should be stored in a different location from that containing the working data, and in an environment that ensures they remain in good condition. When hardware or software changes take place, special care should be taken that all necessary data continues to be accessible, at least, through the full retention period. In the absence of any indication, all records should be kept for a minimum period of five years.

AMC 2—AMC2 ADR.OR.D.035_ Record keeping

RECORDING OF AIRCRAFT MOVEMENTS

- (a) The aerodrome operator should employ a system to be used for recording the aircraft movements at the aerodrome.
- (b) Such a system should allow the aerodrome operator to record:
- (1) the number of movements of each aircraft type using the aerodrome;
 - (2) the type of each aircraft movement (commercial air transportation, cargo, etc.);
 - (3) the date of each movement; and

(4) the number of passengers.

~~(e) Such records should be kept for a minimum of 5 years.~~

~~(d)(c)~~ The system used should also satisfy ~~paragraphs (b) to (f)~~ the provisions of AMC1-ADR.OR.D.035.

GM1-ADR.OR.D.035 – Record keeping

GENERAL

Microfilming or optical storage of records may be carried out at any time. The records should be as legible as the original record, and remain so for the required retention period.

SUBPART E – AERODROME MANUAL (ADR.OR.E)

AMC1-ADR.OR.E.005 – Aerodrome manual

GENERAL

- (a) The aerodrome manual may vary in detail according to the complexity of the operation, and of the type of the aerodrome.
- (b) The aerodrome manual or parts of it may be presented in any form, including electronic form. In all cases, the accessibility, usability, and reliability should be assured.
- (c) The aerodrome manual should be such that:
 - (1) all parts of the manual are consistent and compatible in form and content;
 - (2) the manual can be readily amended; and
 - (3) the content and amendment status of the manual is controlled and clearly indicated.
- (d) The aerodrome manual should include a description of its amendment and revision process specifying:
 - (1) the person(s) who may approve amendments or revisions;
 - (2) the conditions for temporary revisions and/or immediate amendments, or revision required in the interest of safety; and
 - (3) the methods by which all personnel and organisations are advised of changes to the aerodrome manual.
- (e) The aerodrome manual may contain parts of, or refer to other controlled documents, such as aerodrome equipment manual, which are available at the aerodrome for use by the personnel.

AMC2-ADR.OR.E.005—(i)(2) Aerodrome manual

LANGUAGE OF THE AERODROME MANUAL

A translated version of the relevant parts of the aerodrome manual is an acceptable means to comply with the relevant requirement. In any case, the persons who are going to use the manual should be able to read and understand it.

AMC3 ADR.OR.E.005 Aerodrome manual

AERODROME MANUAL

- (a) The aerodrome manual should have the following structure, and include, at least, the following information; if an item is not applicable, the indication 'Not applicable' or 'Intentionally blank' should be inserted, along with the relevant reason:

A. PART A – GENERAL

0.- Administration and control of the aerodrome manual including the following:

0.1. Introduction:

0.1.1- a statement signed by the accountable manager that the aerodrome

manual complies with all applicable requirements, and with the terms of the certificate;

0.1.2- a statement signed by the accountable manager that the aerodrome manual contains operational instructions that are to be complied with by the relevant personnel;

0.1.3- a list and brief description of the various parts, their contents, applicability, and use;

0.1.4- explanations, abbreviations, and definitions of terms needed for the use of the manual;

0.2 System of amendment and revision:

0.2.1- details of the person(s) responsible for the issuance and insertion of amendments and revisions;

0.2.2- a record of amendments and revisions with insertion dates, and effective dates;

0.2.3- a statement that handwritten amendments and revisions are not permitted, except in situations requiring immediate amendment, or revision in the interest of safety;

0.2.4- a description of the system for the annotation of pages, or paragraphs and their effective dates;

0.2.5- a list of effective pages or paragraphs;

0.2.6- annotation of changes; (in the text and, as far as practicable, on charts and diagrams);

0.2.7- temporary revisions; and

0.2.8- description of the distribution system and a distribution list for the aerodrome manual, its amendments, and revisions.

1.- General information

General information including the following:

1.1 purpose and scope of the aerodrome manual;

1.2 legal requirements for an aerodrome certificate and the aerodrome manual as prescribed in Part-ADR.OR;

1.3 conditions for use of the aerodrome by its users;

1.4 the obligations of the aerodrome operator; rights of the competent authority Competent Authority and guidance to staff on how to facilitate audits/inspections by Competent Authority personnel.

B. PART B — AERODROME ADMINISTRATION,—MANAGEMENT SYSTEM, INCLUDING SAFETY, QUALIFICATION AND QUALITY AND SECURITY MANAGEMENT FOR AERONAUTICAL DATA AND AERONAUTICAL INFORMATION PROVISION ACTIVITIES TRAINING REQUIREMENTS;

2.- A description of the management system, including the following:

2.1- Aerodrome organisation and responsibilities including the following: a description of the organisational structure, including the general organigramme organogram and other departments' organigrammes organograms. The organigramme organogram

should depict the relationship between the departments. Subordination and reporting lines of all levels of organisational structure (Departments, Sections, etc.) related to safety should be shown. ~~Responsibilities and duties of management and nominated persons as well as other operational, maintenance personnel should be included.~~

Names, authorities, responsibilities, and duties of management and nominated persons; responsibilities and duties of other operational, maintenance personnel should also be included.

2.2.- A description of the safety management system, including:

2.2.5 scope of the safety management system;

2.2.6 safety policy and objectives;

2.2.7 safety responsibilities of key safety personnel;

2.2.8 documentation control procedures;

~~2.2.9—scope of the safety risk management system;~~

~~2.2.10—safety policy and objectives;~~

~~2.2.11—safety responsibilities of key safety personnel;~~

~~2.2.12—documentation control procedures;~~

2.2.13 2.2.9 process, including hazard identification and risk management assessment schemes;

2.2.14 2.2.10 monitoring of implementation and effectiveness of safety actions, and risk mitigation measures;

2.2.15 2.2.11 safety performance monitoring;

2.2.16 2.2.12 safety reporting (including hazard reporting) and investigation;

2.2.17 2.2.13 emergency response planning;

2.2.18 2.2.14 management of change (including organisational changes with regard to safety responsibilities); and

2.2.19 2.2.15 safety promotion; and

2.2.16 safety management system outputs.

2.3 A description of the compliance monitoring ~~function~~ and related procedures.

2.4 A description of the quality and security management system for aeronautical data and aeronautical information provision activities and related procedures, including those for meeting the relevant safety, and security management objectives.

2.5 Procedures for reporting to the ~~competent authority~~. Competent Authority including handling, notifying and reporting accidents, serious incidents, and occurrences. This section should include, at least, the following:

(a) definition of accident, serious incident and occurrence and of the relevant responsibilities of all persons involved;

(b) illustrations of forms to be used (or copies of the forms themselves), instructions on how they are to be completed, the addresses to which they should be sent and the time allowed for this to be done;

(c) procedures and arrangements for the preservation of evidence, including recordings, following a reportable event;

2.6 Policy and procedures related to the use of alcohol and illicit or prescribed, psychoactive substances and medicines.

2.7- Procedures for-;

2.7.1 complying with safety directives and;

2.7.2 reaction to safety problems; and

2.7.3 handling of safety recommendations issued by Safety Investigation Authorities.

2.8- A description of the method for recording aircraft movements, including movement and aircraft type, dates, and number of passengers.

3. ~~Procedures~~ Required aerodrome personnel qualifications. Moreover, procedures related to training including-;

3.1 the following-:

~~3.1~~ training programme, including the following:

3.1.1 responsibilities, frequencies, syllabi, and checking programmes the identified training standards for all personnel involved in the operation, rescue and firefighting maintenance and management of the aerodrome, and those persons operating unescorted on the movement area and other operational areas of the aerodrome. Training syllabi and checking programmes should be developed in accordance with the requirements pertaining to their duties, as prescribed in Part ADR.OPS.

3.1.2 procedures:

3.1.2.1 for training and checking of the trainees;

3.1.2.2 to be applied in the event that personnel do not achieve or maintain the required standards.

~~3.3~~ 3.1.3 description of documentation to be stored and storage periods.

3.2 the proficiency check programme, including responsibilities and frequencies;

3.2.1 procedures to be applied in the event that personnel do not achieve the required standards.

3.2.3 description of documentation to be stored and storage periods.

C. PART C — PARTICULARS OF THE AERODROME SITE

4.- A description of the aerodrome site including in particular, the following information:

4.1- a plan showing the distance of the aerodrome from the nearest city, town, or other populous area;

4.2- detailed maps and charts of the aerodrome showing the aerodrome's location (longitude and latitude) and boundaries, major facilities, aerodrome reference

SUBPART E – AERODROME MANUAL (ADR.OR.E)

point, layout of runways, taxiways and aprons, aerodrome visual and non-visual aids, and wind direction indicators;

- 4.3 a plan showing the location of any aerodrome facilities and equipment outside the boundaries of the aerodrome;
- 4.4- description of the physical characteristics of the aerodrome, elevations, visual and non-visual aids, as well as the information regarding the aerodrome reference temperature, strength of pavements, rescue and ~~fire-fighting~~ firefighting level of protection, ground aids and main obstacles;
- 4.5- description of any cases of exemptions or derogations, equivalent level of safety, special conditions, and operating limitations; and
- 4.6- description of the types of operations that the aerodrome is approved to conduct.

D.- PART ~~CD~~ — PARTICULARS OF THE AERODROME REQUIRED TO BE REPORTED TO THE AERONAUTICAL INFORMATION SERVICE

5.- The aeronautical information services available and the procedures for the promulgation of general information, including the following:

- 5.1- the name of the aerodrome;
- 5.2- the location of the aerodrome;
- 5.3- the geographical coordinates of the aerodrome reference point determined in terms of the World Geodetic System — 1984 (WGS-84) reference datum;
- 5.4- the aerodrome elevation and geoid undulation;
- 5.5- the elevation of each threshold and geoid undulation, the elevation of the runway end, and any significant high and low points along the runway, and the highest elevation of the touchdown zone of a precision approach runway;
- 5.6- the aerodrome reference temperature;
- 5.7- details of the aerodrome beacon; and
- 5.8- the name of the aerodrome operator and contact details (including telephone numbers) of the aerodrome operator at which may be contacted at all times.

6.- Aerodrome dimensions and related information, including the following:

- 6.1- runway — true bearing, designation number, length, width, displaced threshold location, slope, surface type, type of runway and, for a precision approach runway, the existence of an obstacle free zone;
- 6.2 length, width and surface type of strip, runway end safety areas, stopways; length, width and surface type of taxiways; apron surface type and aircraft stands; clearway length and ground profile;
- 6.3- visual aids for approach procedures, approach lighting type and visual approach slope indicator system; marking and lighting of runways, taxiways, and aprons; other visual guidance and control aids on taxiways and aprons, location and type of visual docking guidance system; availability of standby power for lighting;
- 6.4- the location and radio frequency of VOR aerodrome checkpoints;
- 6.5- the location and designation of standard taxi routes;
- 6.6- the geographical coordinates of each threshold, appropriate taxiway centre line

points, and aircraft stands;

- 6.7- the geographical coordinates, and the top elevation of significant obstacles in the approach and take-off areas, in the circling area and in the vicinity surroundings of the aerodrome; (in the form of charts);
- 6.8 pavement surface type and bearing strength using the Aircraft Classification Number – Pavement Classification Number (ACN-PCN) method;
- 6.9- pre-flight altimeter check locations established and their elevation;
- 6.10- declared distances;
- 6.11- contact details (telephone/telex/fax numbers and capability e-mail address) of ~~with regard to the aerodrome coordinator for~~ the removal of disabled aircraft;
- ~~6.12 category, and information on the capability to remove disabled aircraft, expressed in terms of rescue and fire fighting; and the largest aircraft type;~~
- 6.12 rescue and firefighting level of protection; types and amounts of extinguishing agents normally available at the aerodrome; and
- 6.13- exemptions or derogations from the applicable requirements, cases of equivalent level of safety, special conditions, and limitations.

E.- PART ~~DE~~ – PARTICULARS OF ~~THE AERODROME~~ OPERATING PROCEDURES OF THE AERODROME, ITS EQUIPMENT, AND SAFETY MEASURES

7.- Aerodrome reporting, including:

7.1- arrangements and procedures for reporting ~~any~~ changes to the ~~competent authority and recording the aerodrome information set out in the AIP and requesting the issue of NOTAM, including reporting of~~ changes; to the Competent Authority and recording of the reporting of changes;

8.- Procedures for accessing the aerodrome movement area, including:

8.1 coordination with the security agencies;

8.2- prevention of unauthorised entry into the movement area;

~~9.— Aerodrome emergency plan including:~~

~~9.1— dealing with emergencies at the aerodrome or in its vicinity;~~

~~9.2— tests for aerodrome facilities and equipment to be used in emergencies, including their frequency;~~

~~9.3— exercises to test emergency plans, including their frequency.~~

~~10.— Rescue and fire fighting, including:~~

~~10.2 description of facilities, equipment, personnel and procedures for meeting the fire fighting requirements.~~

~~11.9.~~ Procedures and responsible personnel for the inspection, assessment and reporting of the condition of the aerodrome movement area and ~~obstacle limitation surfaces, other operational areas and facilities,~~ (including:

~~11.1 responsible personnel for~~ runway surface friction characteristics assessments and water-depth measurements;), including:

~~11.2~~ 9.1 arrangements and means of communicating with the air traffic services unit during inspections;

~~11.3~~ 9.2 inspection checklists, logbook, and record-keeping; and

~~11.4~~ 9.3 inspection intervals and times; reporting results and follow-up actions.

~~12.10.~~ Procedures for the inspection, and routine and emergency maintenance of visual ~~aids~~ and non-visual aids, as appropriate, and the aerodrome electrical systems, including:

~~12.10.1-~~ inspection checklists, logbook, and record keeping; and

~~12.10.2-~~ inspection intervals and times; reporting results and follow-up actions.

~~13.— Maintenance~~ 11. Operating, maintenance and repair instructions, servicing information, troubleshooting and inspection procedures of aerodrome equipment.

~~14.12.~~ Procedures for maintenance of the movement area, including:

~~14.1~~ paved areas; unpaved runways and taxiways; runways and runway strips and aerodrome drainage.

~~15.13.~~ Procedures for aerodrome works, including:

~~15.13.1-~~ coordinating, planning, and carrying out construction and maintenance work; and

~~15.2-13.2~~ arrangements and means of communicating with air traffic control services unit during the progress of such work.

~~16-14.~~ Procedures for apron management, including:

~~1614.1-~~ transfer of the aircraft between air traffic control services unit, and the apron management unit;

~~1614.2-~~ allocation of aircraft parking positions;

~~1614.3-~~ engine start and aircraft push-back; and

~~1614.4-~~ marshalling and 'follow-me' service.

~~17-15.~~ Procedures for apron safety management, including:

~~1715.1-~~ protection from jet blasts;

~~1715.2-~~ enforcement of safety precautions during aircraft refuelling operations;

~~1715.3-~~ apron cleaning/sweeping; and

~~1715.4-~~ monitoring compliance of personnel on the apron with safety procedures.

~~18-16.~~ Procedures for the control of vehicles operating on or in the vicinity, or the movement area, including traffic rules, speed limits, and method for issuing driving permits, and enforcement means.

~~19-17.~~ Procedures for wildlife hazard management, including assessing wildlife hazards and arrangements for implementation of the wildlife control programme, and promulgation of the relevant information to the AIS; wildlife strike form.

~~20-18.~~ Procedures for obstacle control and monitoring within and outside of the aerodrome boundaries, and notification to the competent authority Competent Authority, of the nature and location of obstacles, and any subsequent addition, or removal of obstacles for action as necessary, including amendment of the AIS publications; inspection checklists, logbook, and record keeping; inspection intervals and times; reporting results and follow-up actions.

19. Aerodrome emergency plan including:

19.1 dealing with emergencies at the aerodrome or in its surroundings;

19.2 tests for aerodrome facilities and equipment to be used in emergencies, including their frequency; and

19.3 exercises to test emergency plans, including their frequency.

20. Rescue and firefighting, including description of facilities, equipment, personnel and procedures for meeting the firefighting requirements.

21.- Removal plan of disabled aircraft, including relevant arrangements, equipment, and procedures for its implementation.

22.- Procedures for ensuring the safe handling and storage of fuel and dangerous goods in the aerodrome, including:

22.1- equipment, storage areas, delivery, dispensing ~~and~~ handling, and safety measures;

22.2- quality and correct specification of aviation fuel; audit and inspection intervals, checklists, sampling and record keeping.

23.- Low visibility operations: description of operational procedures, including coordination with ~~Air Traffic Services~~ air traffic services unit and apron management unit, standard

taxiing routes, control of activities, and measurement and reporting of runway visual range.

24.- Procedures for ~~the~~ winter operations.

25.- Snow removal plan and procedures for its implementation, including a description of the available means and relevant arrangements.

26.- Procedures for operations in adverse weather conditions.

27.- Procedures for night operations.

28.- Procedures for the protection of radar and other navigational aids, control of activities, and ground maintenance in the vicinity of these installations.

29.- Procedures and measures for the prevention of fire at the aerodrome.⁴

(b) All procedures contained in the aerodrome manual should include and clearly define the roles, responsibilities, and contact details of responsible aerodrome personnel, other persons or organisations, including the ~~competent authority~~ Competent Authority and other state agencies involved, as appropriate, and take into account the need for establishing direct communication during non-working hours.

GM1-~~ADR.OR.E.010~~—005 Aerodrome manual

~~FORM OF THE~~ AERODROME MANUAL

(a) Form of the aerodrome manual

The aerodrome manual is a key document both for the aerodrome operator and the ~~competent authority~~ Competent Authority. The manual is the source document describing how the aerodrome infrastructure, facilities, and operational procedures will operate safely.

As well as the operational procedures, the ~~competent authority~~ Competent Authority will expect the aerodrome manual to be an accurate reflection of the day-to-day functioning of the aerodrome's safety management system, and its safety culture. It will need to show how the aerodrome intends to measure its performance against safety targets and objectives. The reader of an aerodrome manual should be given a clear statement of how safety is developed, managed, and maintained on the aerodrome. All safety policies, operational procedures and instructions should be contained in detail when relevant or cross-referenced to other controlled, formally accepted or recognised, publications.

At larger aerodromes, the size and complexity of operations, and related procedures may dictate that these procedures could not easily be included in a single document. In such circumstances, it is acceptable to identify and reference within the aerodrome manual the procedures which are not included within it. If this system is to be successful, it is essential that any referenced information, documentation, and procedures are made available as necessary to all operational staff in a similar way as the aerodrome manual itself. For that purpose, a computerised database containing the referenced procedures and information could be suitable. For many small aerodromes, the aerodrome manual can be both simple and brief as long as it covers procedures essential for satisfactory day-to-day operations. Nevertheless, it is possible to adopt a common format embracing the essential elements that define a safety management system.

~~(a)(b) GM2-ADR.OR.E.005—Structure~~ Purpose of the aerodrome manual

~~PURPOSE AND SCOPE OF THE AERODROME MANUAL~~

An efficient management structure and a systematic approach to aerodrome operation is essential. The aerodrome manual should contain all the relevant information to describe this structure satisfactorily. It is one of the means by which all aerodromerelevant operating staff can be informed as to their duties and responsibilities with regard to safety. It should describe the aerodrome infrastructure, services and facilities, all operating procedures, and any restrictions on aerodrome availability.

Accountability for safety must start at the very top of any organisation. One of the key elements in establishing safe working practices is the 'top down' approach where all staff should understand the safety aims of the organisation, the chain of command, and their own responsibilities and accountabilities. As safety management principles are applied, the aerodrome manual should be expanded to describe clearly how the safety of operations is to be managed. To a reader or user of the aerodrome manual, there should never be any doubt in terms of 'safety accountability' for each domain or activity described. Each section should define who is accountable, who is responsible, who has the authority, who has the expertise, and who actually carries out the tasks described in any section.

The principle objective of an aerodrome manual should be to show how management will accomplish its safety responsibilities. The aerodrome manual will set out the policy and expected standards of performance, and the procedures by which they will be achieved.

The aerodrome operator should ensure that:

- (1) the responsibilities of the aerodrome operator are clearly described;
- (2) the tasks and activities that are to be ~~done~~performed by the aerodrome operator or its subcontractors are listed; and
- (3) the means and procedures in order to complete these tasks and activities are described or appended, together with the necessary details on their frequencies and operating modes.

Where responsibilities are attributed to other stakeholders, the aerodrome manual should clearly identify them.

GM2 ADR.OR.E.005 Aerodrome manual

CONTENTS

The numbering system described in AMC3 ADR.OR.E.005 should be maintained even if there are sections that, because of the nature of the aerodrome or the types of operation, are not applicable.

GM1 ADR.OR.E.005 (j) Aerodrome manual

HUMAN FACTORS PRINCIPLES

Guidance material on the application of human factors principles may be found in the ICAO Human Factors Training Manual (Doc 9683).

AMC/GM to ANNEX III – Part Operations Requirements (Part-OPS)**SUBPART A – AERODROME DATA (ADR.OPS.A)****AMC-AMC1 ADR-OPS.A.005 – ~~Aeronautical~~ Aerodrome Data ^{TEXT ADD}**

- (a) Data relevant to the aerodrome and available services should include, but may not be limited to, items in the following list:
- (1) aerodrome reference point;
 - (2) aerodrome and runway elevations;
 - (3) aerodrome reference temperature;
 - (4) aerodrome dimensions and related information;
 - (5) strength of pavements;
 - (6) pre-flight altimeter check location;
 - (7) declared distances;
 - (8) condition of the movement area and related facilities;
 - (9) disabled aircraft removal;
 - (10) rescue and ~~fire-fighting; firefighting; and~~
 - (11) visual approach slope indicator systems₇.
- (b) The aerodrome operator should provide measure and report to the aeronautical information services obstacles and terrain data in Area 3, and in Area 2 (the part within the aerodrome boundary) in degrees, minutes, seconds and tenths of the aerodrome (Area 3) and in the Terminal Control Area (Area 2) seconds. In addition, the top elevation, type, marking and lighting (if any) of obstacles should be reported to the aeronautical information services.
- (c) Electronic obstacle data for all obstacles in Area 2 (the part within the aerodrome boundary) that are assessed as being a hazard to air navigation should be provided.
- (d) Electronic terrain and obstacle data should be provided for:
- (1) Area 2a, for those that penetrate the relevant obstacle data collection surface;
 - (2) penetrations of the take-off flight path area obstacle identification surfaces; and
 - (3) penetrations of the aerodrome obstacle limitation surfaces.
- ~~(b)~~(e) Electronic terrain and obstacle data should be provided for Area 4 for terrain and obstacles that penetrate the relevant obstacle data collection surface, for all runways where precision approach Category II or III operations have been established and where detailed terrain information is required by operators to enable them to assess the effect of terrain on decision height determination by use of radio altimeters.
- ~~(c)~~(f) The aerodrome operator should establish arrangements with the ANS Air Traffic Services providers and the competent authority Competent Authority for the provision of obstacles and terrain data in the Terminal Control Area (Area 2) outside of the aerodrome boundary₇.

GM-

GM1 ADR-OPS.A.005 — ~~Aeronautical~~ Aerodrome data

AERODROME REFERENCE POINT

- (a) The aerodrome reference point ~~is~~should be located near the initial or planned geometric centre of the aerodrome and normally ~~remains~~should remain where first established~~;~~
- (b) The aerodrome reference point ~~is~~should be reported to the ~~AIS~~Aeronautical information services in degrees, minutes~~,~~ and seconds~~;~~

AERODROME AND RUNWAY ELEVATIONS

The following ~~are~~should be measured and reported to the ~~AIS~~Aeronautical information services:

- (a) The aerodrome elevation and geoid undulation at the aerodrome elevation position to the accuracy of one-half metre or foot;
- (b) For non-precision approaches, the elevation and geoid undulation of each threshold, the elevation of the runway end and any significant high and low points along the runway, to the accuracy of one-half metre or foot;
- (c) For precision approach runway, the elevation and geoid undulation of the threshold, the elevation of the runway end and the highest elevation of the touchdown zone, to the accuracy of one-quarter metre or foot~~;~~

AERODROME REFERENCE TEMPERATURE

- (a) The aerodrome reference temperature ~~is~~should be determined in degrees Celsius~~;~~
- (b) The aerodrome reference temperature ~~is~~should be the monthly mean of the daily maximum temperatures for the hottest month of the year (the hottest month being that which has the highest monthly mean temperature), averaged over a period of ~~five~~ (5) years~~;~~

AERODROME DIMENSIONS AND RELATED INFORMATION

The following data are measured or described, as appropriate, for each facility provided on the aerodrome:

- (a) Runway~~:~~
 - (1) true bearing to one-hundredth of a degree;
 - (2) designation number;
 - (3) length;
 - (4) width;
 - (5) displaced threshold location to the nearest metre or foot;
 - (6) longitudinal slope;
 - (7) surface type;
 - (8) type of runway~~;~~ and
 - (9) for a precision approach runway category I, the existence of an obstacle free zone when provided~~;~~

- (b) Strip/Runway End Safety Area/Stopway
 - (1) Length ~~and~~, width to the nearest metre or foot; and
 - (2) Surface type ~~;~~
- (c) Taxiway
 - (1) Designation;
 - (2) Width; and
 - (3) Surface type ~~;~~
- (d) Apron
 - (1) Surface type; and
 - (2) Aircraft stands ~~;~~
- (e) ~~the~~The boundaries of the air traffic control service;
- (f) ~~clearway:~~Clearway
 - (1) length to the nearest metre or foot; and
 - (2) ground profile ~~;~~
- (g) ~~visual~~Visual aids for approach procedures, marking and lighting of runways, taxiways and aprons, other visual guidance and control aids on taxiways and aprons, including ~~taxi-~~runway holding positions, intermediate holding positions and stopbars, and location and type of visual docking guidance systems;
- (h) ~~location~~Location and radio frequency of any VOR aerodrome checkpoint;
- (i) ~~location~~Location and designation of standard taxi-routes; and
- (j) ~~distances~~Distances to the nearest metre or foot of localiser and glide path elements comprising an instrument landing system (ILS) or azimuth and elevation antenna of a microwave landing system (MLS) in relation to the associated runway extremities ~~;~~
- (k) The geographical coordinates of:
 - (1) each threshold;
 - (2) appropriate taxiway centre line points; and
 - (3) each aircraft stand;are measured and reported to the AISaeronautical information services in degrees, minutes, seconds and hundredths of seconds.

STRENGTH OF PAVEMENTS

- (a) The bearing strength of a pavement intended for aircraft of apron (ramp) mass greater than 5-700-kg ~~is~~should be made available using the aircraft classification – pavement classification number (ACN-PCN) method, by reporting all of the following information:
 - (1) the pavement classification number (PCN);
 - (2) pavement type for ACN-PCN determination;
 - (3) subgrade strength category;
 - (4) maximum allowable tire pressure category or maximum allowable tire pressure

value; and

(5) evaluation method~~7~~.

(b) For the purposes of determining the ACN, the behaviour of a pavement should be classified as equivalent to a rigid or flexible construction;

~~(b)~~(c) Information on pavement type for ACN-PCN determination, subgrade strength category, maximum allowable tire pressure category and evaluation method, ~~is~~should be reported using the following codes:

(1) Pavement type for ACN-PCN determination:

- (i) — Rigid pavement: Code R;
- (ii) — Flexible pavement: Code F;

(2) Subgrade strength category:

- (i) High strength: ~~characterized~~characterised by $K = 150 \text{ MN/m}^3$ and representing all K values above 120 MN/m^3 for rigid pavements, and by $\text{CBR} = 15$ and representing all CBR values above 13 for flexible pavements — Code A;
- (ii) Medium strength: characterised by $K = 80 \text{ MN/m}^3$ and representing a range in K of 60 to 120 MN/m^3 for rigid pavements, and by $\text{CBR} = 10$ and representing a range in CBR of 8 to 13 for flexible pavements — Code B;
- (iii) — Low strength: ~~characterized~~characterised by $K = 40 \text{ MN/m}^3$ and representing a range in K of 25 to 60 MN/m^3 for rigid pavements, and by $\text{CBR} = 6$ and representing a range in CBR of 4 to 8 for flexible pavements — Code C;
- (iv) — Ultra low strength: ~~characterized~~characterised by $K = 20 \text{ MN/m}^3$ and representing all K values below 25 MN/m^3 for rigid pavements, and by $\text{CBR} = 3$ and representing all CBR values below 4 for flexible pavements — Code D;

(3) Maximum allowable tire pressure category:

- (i) ~~Unlimited~~High: no pressure limit — Code W;
- ~~(ii) — High: pressure limited to 1.75 MPa — Code X;~~
- (ii) Medium: pressure limited to 1.2550 MPa — Code X;
- (iii) Low: pressure limited to 1.00 MPa — Code Y;
- (iv) — ~~Low~~Very low: pressure limited to 0.50 MPa — Code Z;

(4) Evaluation method:

- (i) Technical evaluation: representing a specific study of the pavement characteristics and application of pavement behaviour technology — Code T;
- (ii) Using aircraft experience: representing a knowledge of the specific type and mass of aircraft satisfactorily being supported under regular use — Code U;

~~(e)~~(d) The bearing strength of a pavement intended for aircraft of apron (ramp) mass equal to or less than ~~5–700–kg~~, ~~is~~should be reported by ~~giving~~reporting the following information:

CRD to NPA 2011-20 (B.II)
AMC/GM to Annex III – Part-OPS
SUBPART A – AERODROME DATA (ADR.OPS.A)

09/12/201126
Nov 2012

- (1) maximum allowable aircraft mass; and
- (2) maximum allowable tire pressure.

PRE-FLIGHT ALTIMETER CHECK LOCATION

- (a) One or more pre-flight altimeter check locations may be established.
- (b) The elevation of a pre-flight altimeter check location is given as the average elevation, rounded to the nearest metre or foot, of the area on which it is located. The elevation of any portion of a pre-flight altimeter check location may be within 3_m (10_ft) of the average elevation for that location.
- (c) Pre-flight check location may be located on an apron. Locating a pre-flight altimeter check location on an apron enables an altimeter check to be made prior to obtaining taxi clearance and eliminates the need for stopping for that purpose after leaving the apron. Normally an entire apron can serve as a satisfactory altimeter check location.

DECLARED DISTANCES

- (a) The following distances are calculated to the nearest metre or foot for a runway and reported to the AIS and ANSP:
 - (1) Take-off run available (TORA);
 - (2) Take-off distance available (TODA);
 - (3) Accelerate stop distance available (ASDA); and
 - (4) Landing distance available (LDA).
- (b) The take-off run available (TORA), take-off distance available (TODA), accelerate stop distance available (ASDA) and landing distance available (LDA) are calculated according to the following: (all declared distances are illustrated for operations from left to right):
 - (1) Where a runway is not provided with a stopway or a clearway and the threshold is located at the extremity of the runway, the four declared distances should normally be equal to the length of the runway

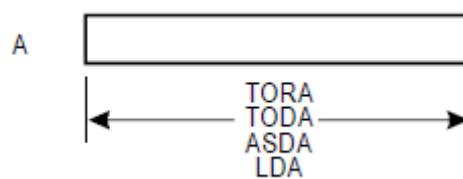

Figure 1

- (2) When a runway is provided with a clearway (CWY), then the TODA will include the length of clearway.

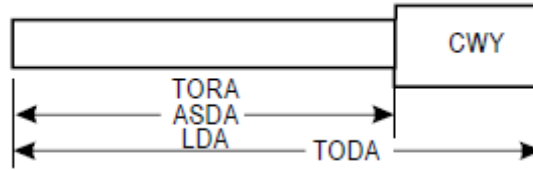

Figure 2

- (3) Where a runway is provided with a stopway (SWY), then the ASDA will include the length of stopway.

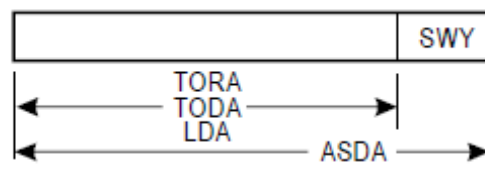

Figure 3

- (4) Where a runway has a displaced threshold, then the LDA will be reduced by the distance the threshold is displaced. A displaced threshold affects only the LDA for approaches made to that threshold; all declared distances for operations in the reciprocal direction are unaffected.

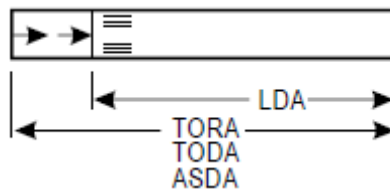

Figure 4

- (5) Where a runway is provided with more than one of the clearway, stopway, or having a displaced threshold, then more than one of the declared distances will be modified. The modification will follow the same principle as in (1)–(4)

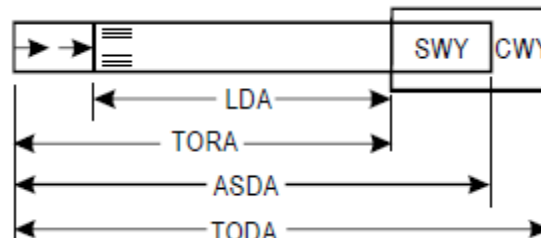

Figure 5

CRD to NPA 2011-20 (B.II)
AMC/GM to Annex III – Part-OPS
SUBPART A – AERODROME DATA (ADR.OPS.A)

09/12/201126
Nov 2012

(c) The information on declared distances may should be provided according to the following table:

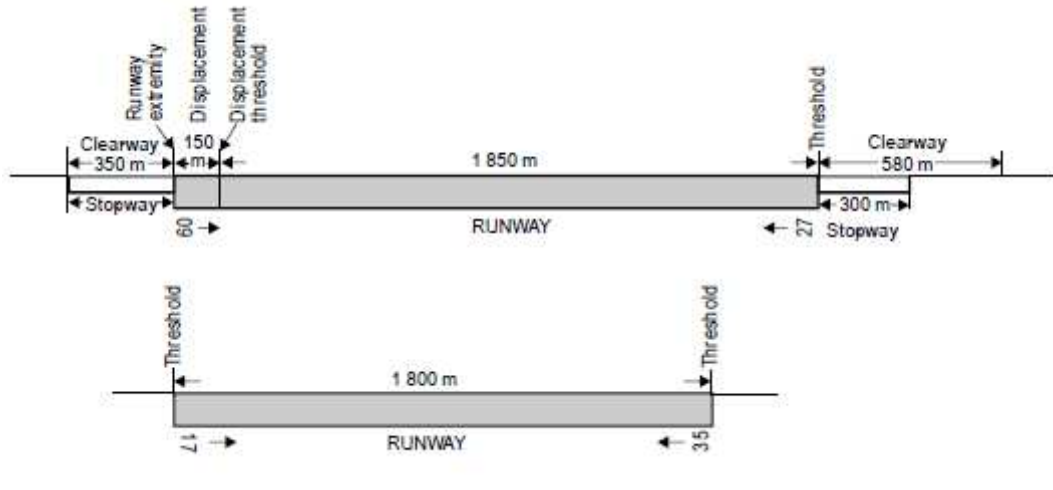

Figure 6

RUNWAY	TORA	ASDA	TODA	LDA
	m	m	m	m
09	2_000	2_300	2_580	1_850
27	2_000	2_350	2_350	2_000
17	NU	NU	NU	1_800
35	1_800	1_800	1_800	NU

Table 1

If a runway direction cannot be used for take-off or landing, or both, because it is operationally forbidden, then this should be declared and the words 'not usable' or the abbreviation 'NU' entered.

(d) When intersection take-offs are performed, the datum line from which the reduced runway declared distances for take-off are determined, should be defined by the intersection of the downwind edge as shown in the figure below:

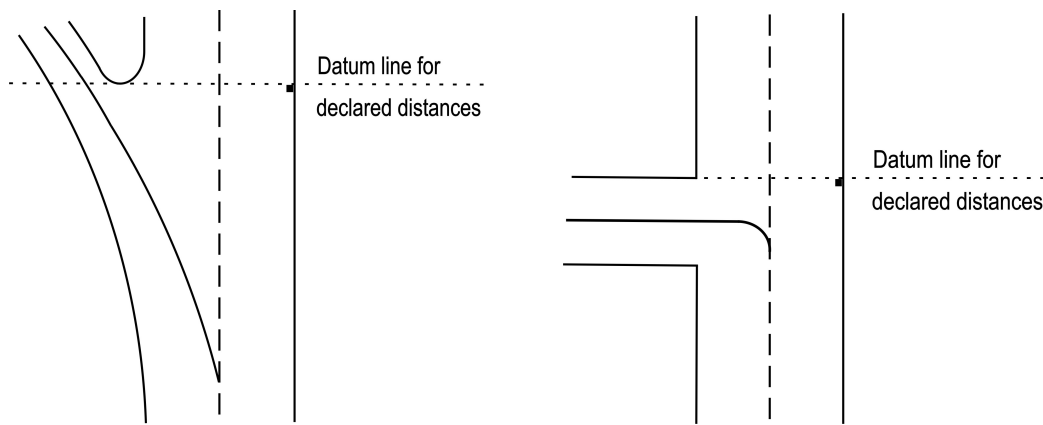

Figure 7

CONDITION OF THE MOVEMENT AREA AND RELATED FACILITIES

The condition of the movement area and the operational status of related facilities is should be monitored and report is made reported, on matters of operational significance or affecting aircraft performance, particularly in respect of the following:

- (a) construction or maintenance work;
- (b) rough or broken surfaces on a runway, a taxiway or an apron;
- (c) snow, slush, ice, wet ice, wet snow on ice or frost or ice on a runway, a taxiway or an apron;
- (d) water on a runway, a taxiway or an apron;
- (e) snow banks or drifts adjacent to a runway, a taxiway or an apron;
- (f) anti-icing or de-icing liquid chemicals or other contaminants on a runway, or a taxiway or apron;
- (g) other temporary hazards, including parked aircraft;
- (h) failure or irregular operation of part or all of the aerodrome visual aids; and
- (i) failure of the normal or secondary power supply.

Water on a runway

Whenever water is present on a runway and, a report description of the runway surface conditions is made, on the centre half of the width of the runway, including the possible assessment of water depth, where applicable, should be made available using the following terms are used:

(a) WetDAMP – the surface shows a change of colour due to moisture;

(a)(b) WET – the surface is soaked but there is no standing water;

~~(1) STANDING WATER — for aeroplane performance purposes, a runway where more than 25 % of the runway surface area (whether in isolated areas or not) within the required length and width being used is covered by water more than 3 mm deep;~~

(c) WATER PATCHES — significant patches of standing water are visible; and

(d) FLOODED — extensive standing water is visible;

Information that a runway or portion thereof maybe slippery when wet ~~is,~~ should be made available to the aerodrome users.

Snow, slush or ice on a runway

~~(a) Runway surface condition is assessed and reported whenever an operational runway is contaminated~~Whenever a runway is affected by snow, slush, or ice or frost;

~~(b) The following terms are used, and it has not been possible to describe~~clear the runway surface condition whenever snow, slush, ice or frost is present and reported:

~~(1) Dry snow;~~

~~(2) Wet snow;~~

~~(3) Compacted snow;~~

~~(4) Wet compacted snow;~~

~~(5) Slush;~~

~~(6) Ice;~~

~~(7) Wet ice;~~

~~(8) Frost;~~

~~(9) Dry snow on ice;~~

~~(10) Wet snow on ice;~~

~~(11) Chemically treated;~~

~~(12) Sanded;~~

~~(c)(a) and include, where applicable~~precipitant fully, the condition of the runway should be assessed, and the friction coefficient measured. Runway condition assessment of contaminant depth;and friction coefficient measurement should be repeated as conditions change.

(b) Friction measurements and/or braking action assessments on surfaces other than runways should be made when an unsatisfactory friction condition can be expected on such surfaces.

~~(d)(c) The contaminant type, distribution, and for loose contaminants, depth for each third of the runway, is~~should be assessed;

~~(e) Runway surface friction measurements are used to conduct runway condition assessment. Runway surface friction measurements made on a runway that is contaminated by slush, wet snow or wet ice should not be reported;~~

~~(f)~~(d) Assessment of the friction of a runway ~~is~~ should be made in descriptive terms of 'estimated' ~~surface friction~~ braking action. The estimated ~~surface friction~~ braking action should be categorised as good, medium to good, medium, medium to poor, and poor, and promulgated in SNOWTAM format as well as using appropriate ~~AT/RTF~~ phraseologies;

~~(g)~~(e) The estimated ~~surface friction~~ braking action, based on the measured coefficient, when the runway is covered by compacted snow or ice only ~~is~~, should be reported according to the following table (indicative):

Measured Coefficient (μ)	Estimated Surface Friction <u>braking action</u>	Code
0.40 and above	Good	5
0.39 to 0.36	Medium to good	4
0.35 to 0.30	Medium	3
0.29 to 0.26	Medium to poor	2
0.25 and below	Poor	1

Table 2

~~(h)~~(f) Assessed surface condition information, including estimated ~~surface friction~~, ~~is~~ braking action, should be reported for each third of a runway. The thirds are called A, B and C;

- (1) For the purpose of reporting information to aeronautical service units, Section A should always be the section associated with the lower runway designation number;
- (2) When giving landing information to a pilot before landing, the sections should be referred to as first, second or third part of the runway. The first part should always mean the first third of the runway as seen in the direction of landing;
- (3) Assessments ~~are~~ should be made along two lines parallel to the runway, i.e. along a line on each side of the centreline approximately 3_m, or that distance from the centreline at which most operations take place;
- (4) In cases where a continuous friction measuring device is used, the mean values are obtained from the friction values recorded for each section;

~~(5) In cases where a spot measuring friction measuring device is used as part of the total assessment of the estimated surface friction, each third of the runway should have three tests carried out on it, where achievable;~~

- (g) Whenever dry snow, wet snow or slush is present on a runway, the mean depth over each third of the runway is assessed to an accuracy of approximately 2 cm for dry snow, 1 cm for wet snow and 0.3 cm for slush.

DISABLED AIRCRAFT REMOVAL

- (a) The contact details (telephone/telex number(s), email address, etc.) of the office of the aerodrome coordinator of operations for the removal of an aircraft disabled on or adjacent to the movement area ~~is~~ should be made available on request to aircraft operators~~;~~
- (b) Information concerning the capability to remove an aircraft disabled on or adjacent to the movement area ~~is~~ should be made available~~;~~
- (c) The capability to remove a disabled aircraft may be expressed in terms of the largest type of aircraft which the aerodrome is equipped to remove.

RESCUE AND ~~FIRE-FIGHTING~~ FIREFIGHTING

- (a) Information concerning the level of protection provided at an aerodrome for aircraft rescue and ~~fire-fighting~~ firefighting purposes ~~is~~ during the hours of operation should be made available~~;~~
- (b) The level of protection normally available at the aerodrome ~~is~~ should be expressed in terms of the category of the rescue and ~~fire-fighting~~ firefighting services and in accordance with the types and amounts of extinguishing agents normally available at the aerodrome~~;~~
- (c) Changes in the level of protection normally available at the aerodrome for rescue and ~~fire-fighting~~ firefighting ~~is~~ should be notified to the appropriate air traffic services units and aeronautical information services units to enable those units to provide the necessary information to arriving and departing aircraft. When such a change has been corrected, the above units ~~are~~ should be advised accordingly~~;~~
- (d) Changes in the level of protection from that normally available at the aerodrome could result from a change in the availability of extinguishing agents, equipment to deliver the agents or personnel to operate the equipment, etc.
- ~~(d)~~ (e) A change in the level of protection is expressed in terms of the new category of the rescue and ~~fire-fighting~~ firefighting services available at the aerodrome.

VISUAL APPROACH SLOPE INDICATOR SYSTEMS

The following information concerning a visual approach indicator system is made available:

- (a) associated runway designation number;
- (b) ~~Type~~ type of system. ~~For an AT-VASIS,;~~ for a PAPI or APAPI installation, the side of the runway on which the lights are installed, i.e. left or right, is given;
- (c) where the axis of the system is not parallel to the runway centre line, the angle of displacement and the direction of displacement, i.e. left or right, is indicated;

- (d) nominal approach slope angle(s); and
- (e) minimum eye height(s) over the threshold of the on-slope signal(s).

AMC-GM2 ADR.OPS.A.005 (a) Aerodrome data

SURVEYING REQUIREMENTS FOR RUNWAY THRESHOLDS, TAXIWAYS AND AIRCRAFT STANDS

(a) Thresholds

- (1) For surveying purposes, threshold positions must be taken as being at the geometric centre of the runway and at the beginning of the paved surface, i.e. the beginning of that portion of the runway usable for landing. Where thresholds are marked by appropriate threshold markings (e.g. displaced thresholds), these must be taken as the threshold points. Where threshold lighting is surveyed, the locations must be described on the diagram accompanying the report. Where there is no threshold lighting, an appropriate point for survey in accordance with the following figures must be selected.

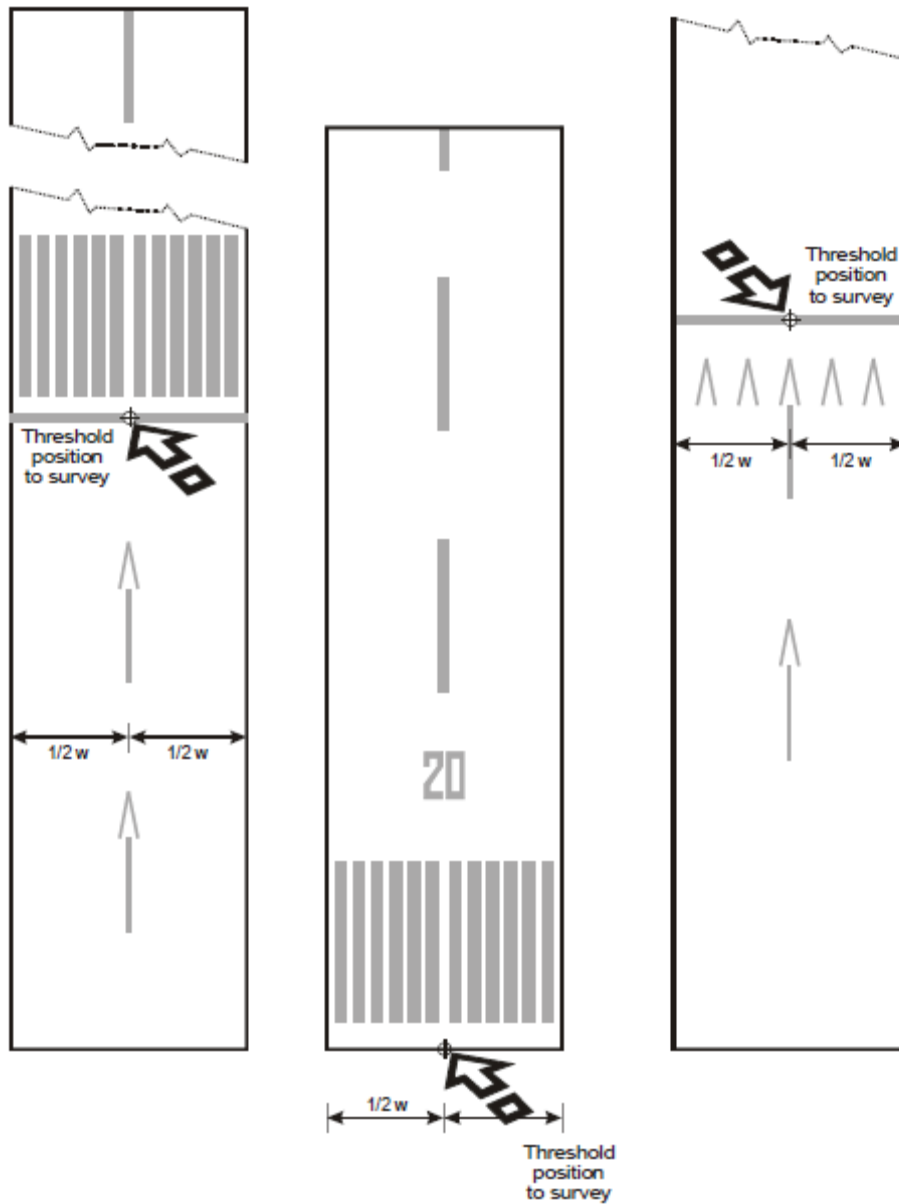

Figure 1

SUBPART A – AERODROME DATA (ADR.OPS.A)

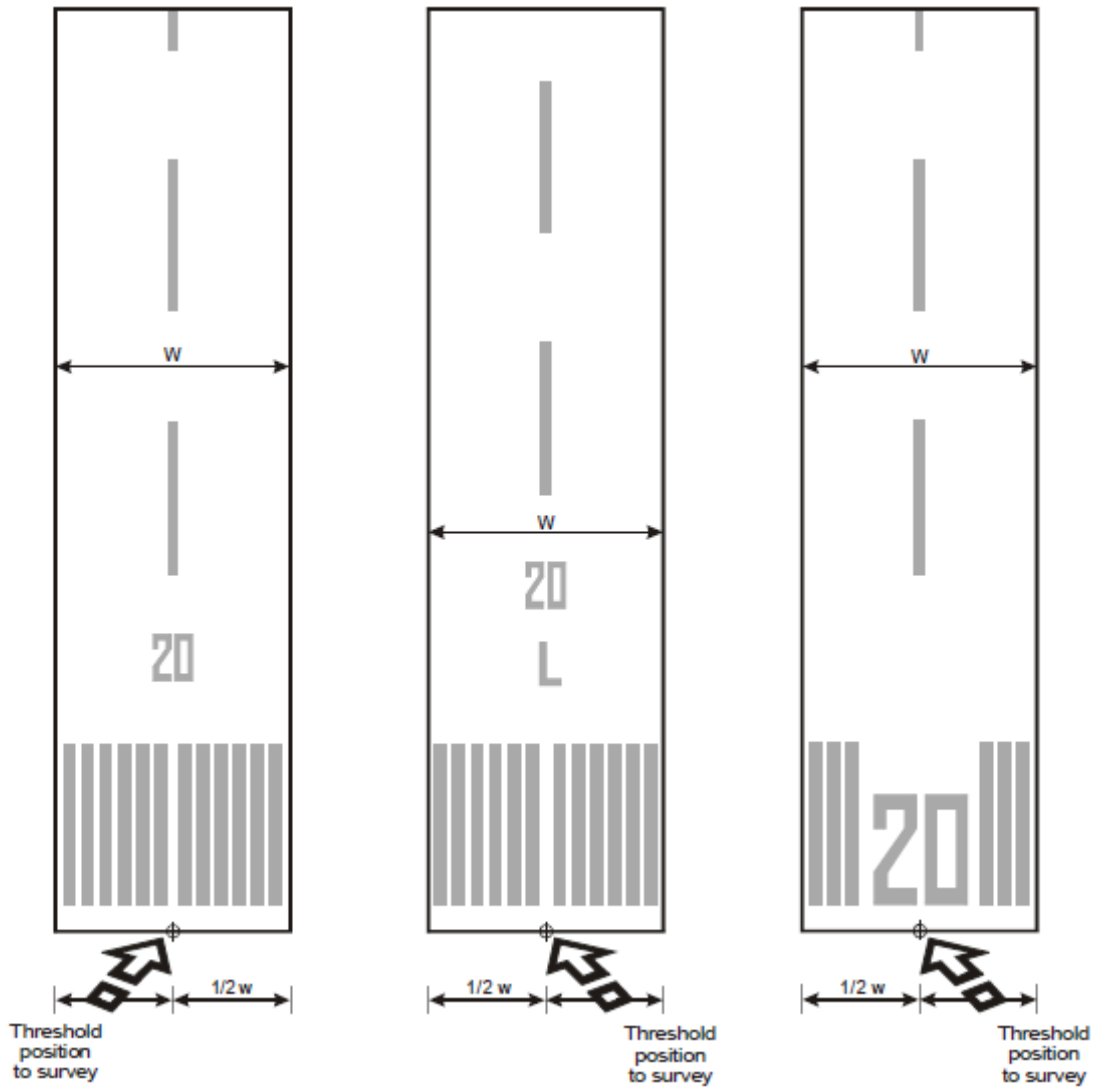

Figure 2

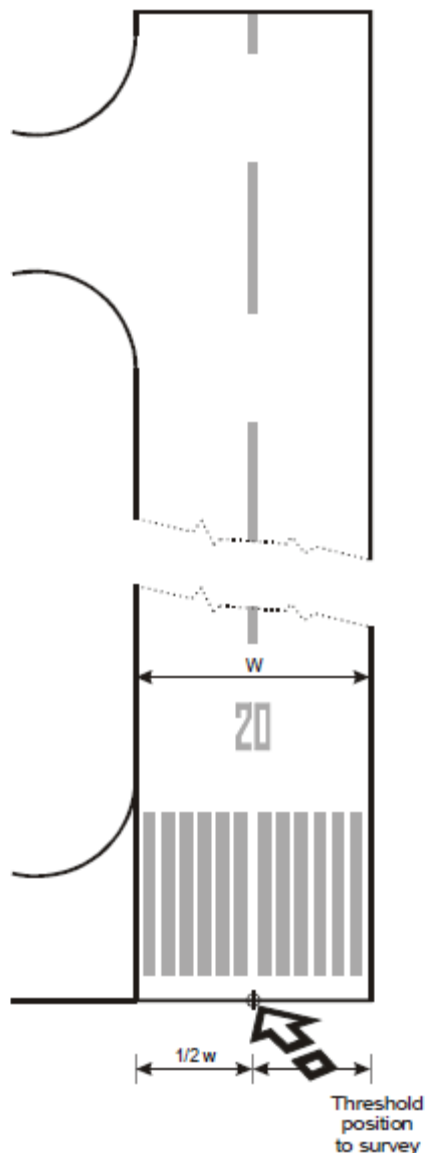

Figure 3

(2) If the runway has only one threshold certified for landing, the runway end position must be surveyed. For surveying purposes, the runway end position (flight path alignment point) must be taken as being at the geometric centre of the runway and at the end of the paved surface, i.e. the end of that portion of the runway usable for landing.

(b) Taxiways and stand/checkpoints – General

(1) Except as provided in (c) (1) below, for surveying purposes the centre (mid-width) of the taxiway centre line marking, apron taxilane marking or the aircraft stand guide line marking must be taken as the reference data.

(2) The points of commencement and ends of straight sections of taxiways, apron taxilanes and aircraft stand point guidance lines markings must be surveyed. Sufficient additional points must be surveyed to maintain the required accuracy along

the lines.

- (3) For curved sections of taxiways, apron taxilanes and aircraft stand guide line markings, the commencement and end of the curved section centre line must be surveyed together with the position of the centre point of the arc and its radius. In the case of a compound curve, the centre and radius of each arc and the commencement and end of each of the arcs must be surveyed. Where this is impracticable in the field, a series of sequential points must be surveyed along the curved section of the centre line with a maximum arc to chord distance not exceeding 0.25 m for taxiways and 0.10 m for apron taxilanes and aircraft stand guide line markings. Sufficient points must be surveyed to maintain the required accuracy along the lines. The surveyor must, in processing the data, conduct a graphical inspection of the survey points to ensure collinearity.

(c) Taxiways

- (1) To permit uninterrupted transition from the actual runway centre line to the taxiway centre line and to provide the required continuity of guidance for the aircraft navigation data base, differentiation must be made between the surface markings and the actual path the aircraft must follow. Therefore, for the guidance of aircraft entering or exiting the runway for take-off or landing, the following must be surveyed:

- (i) the point at which the radius of turn, prescribed by the appropriate authority for each taxiway, is tangential to the runway centre line, and the point at which that radius of turn joins the taxiway centre line marking at a tangent;
- (ii) the point that prescribes the centre of the arc; and
- (iii) the radius of the arc.

Where this is impracticable in the field, a series of sequential points must be surveyed along the curved section of the centre line of taxiways.

- (2) Where taxiway centre line marking is provided on a runway that is part of a standard taxi route, or a taxiway centre line is not coincident with runway centre line, the following points must be surveyed:

- (i) the point on the taxiway marking at which the taxiway enters the runway;
- (ii) the points at which the taxiway deviates from a straight line;
- (iii) the intersection of the taxiway centre line marking and boundary of each 'block' that has been published as part of the airport movement and guidance control system; and
- (iv) the point on the taxiway marking at which the taxiway exits the runway.

- (3) In defining taxiways, the following points must be surveyed at the centre of the centre line marking of each taxiway, as appropriate:

- (i) intermediate holding positions and runway holding positions (including those associated with the intersection of a runway with another runway when the former runway is part of a standard taxi route) and for points established for the protection of sensitive areas for radio navigation aids;

- (ii) taxiway intersection markings;
- (iii) intersection of other taxiways, including taxiways described in point (c) (2) above;
- (iv) intersections of 'blocks' defined for surface movement, guidance and control systems;
- (v) commencement and end of selectable taxiway lighting systems provided as part of the surface movement, guidance and control systems, where different from subparagraph (iv) above; and

(d) Aircraft stand points

(1) In defining the aircraft stands, the following points must be surveyed at the centre of the guide line marking of the aircraft stands, as appropriate:

- (i) taxilane centre lines;
- (ii) lead-in line(s);
- (iii) turning line;
- (iv) straight section of the turning line;
- (v) nose wheel stopping position;
- (vi) true heading of the alignment bar; and
- (vii) lead-out line(s).

(2) Where aircraft stands are utilized by more than one aircraft type and different guide line markings exist, a diagram must be prepared by the surveyor showing the arrangement of the markings in use, together with an indication of the points surveyed. Where all the stands at an aerodrome/heliport are marked uniformly, only a single diagram needs to be prepared.

The points that should be surveyed for a taxiway or an aircraft stand, are shown in the following diagrams:

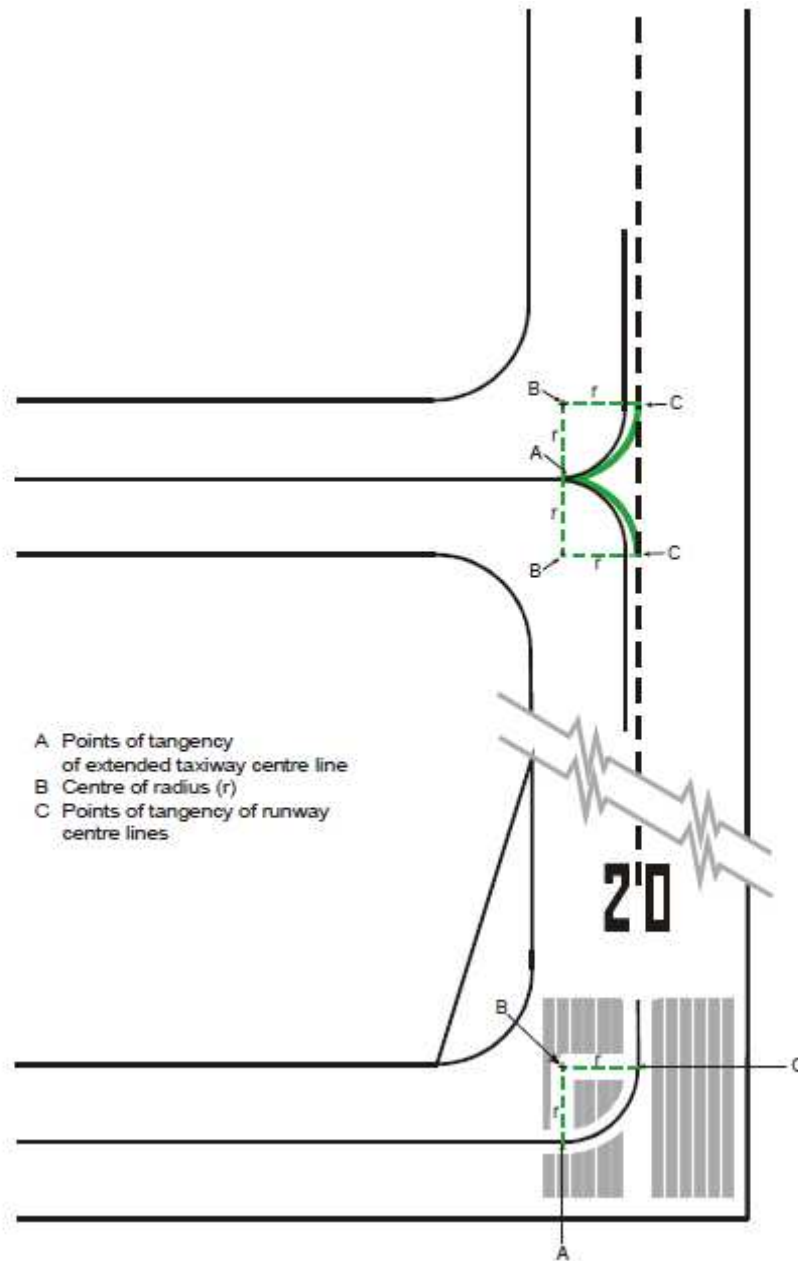

Runway and taxiway intersections to be surveyed

Figure 4

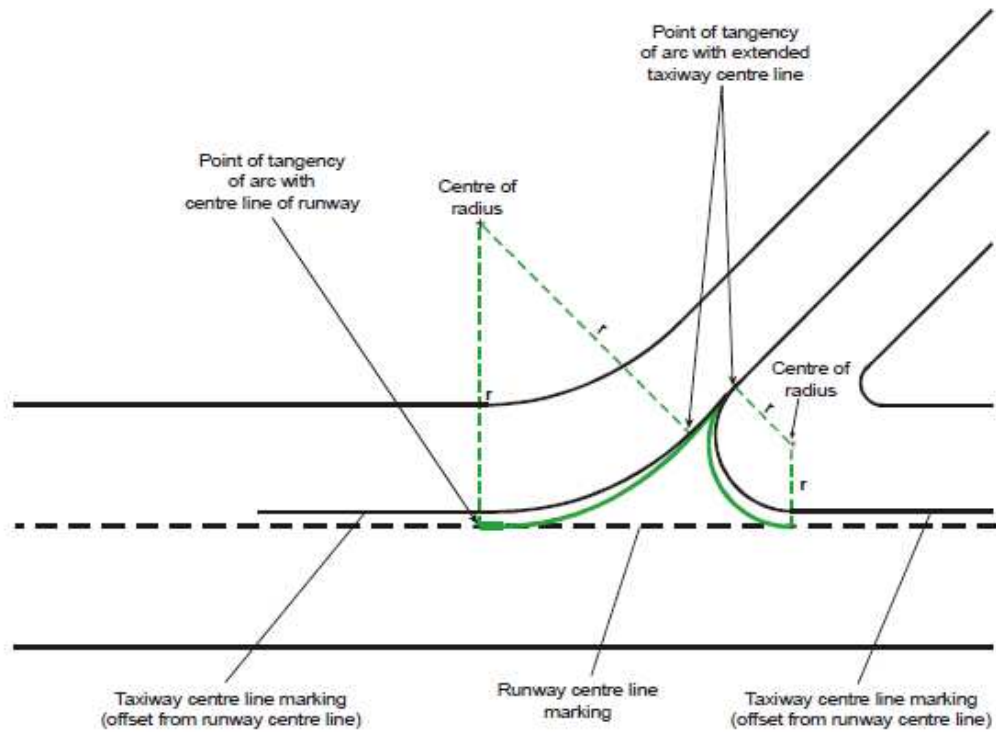

Figure 5 - Runway and taxiway intersections to be surveyed

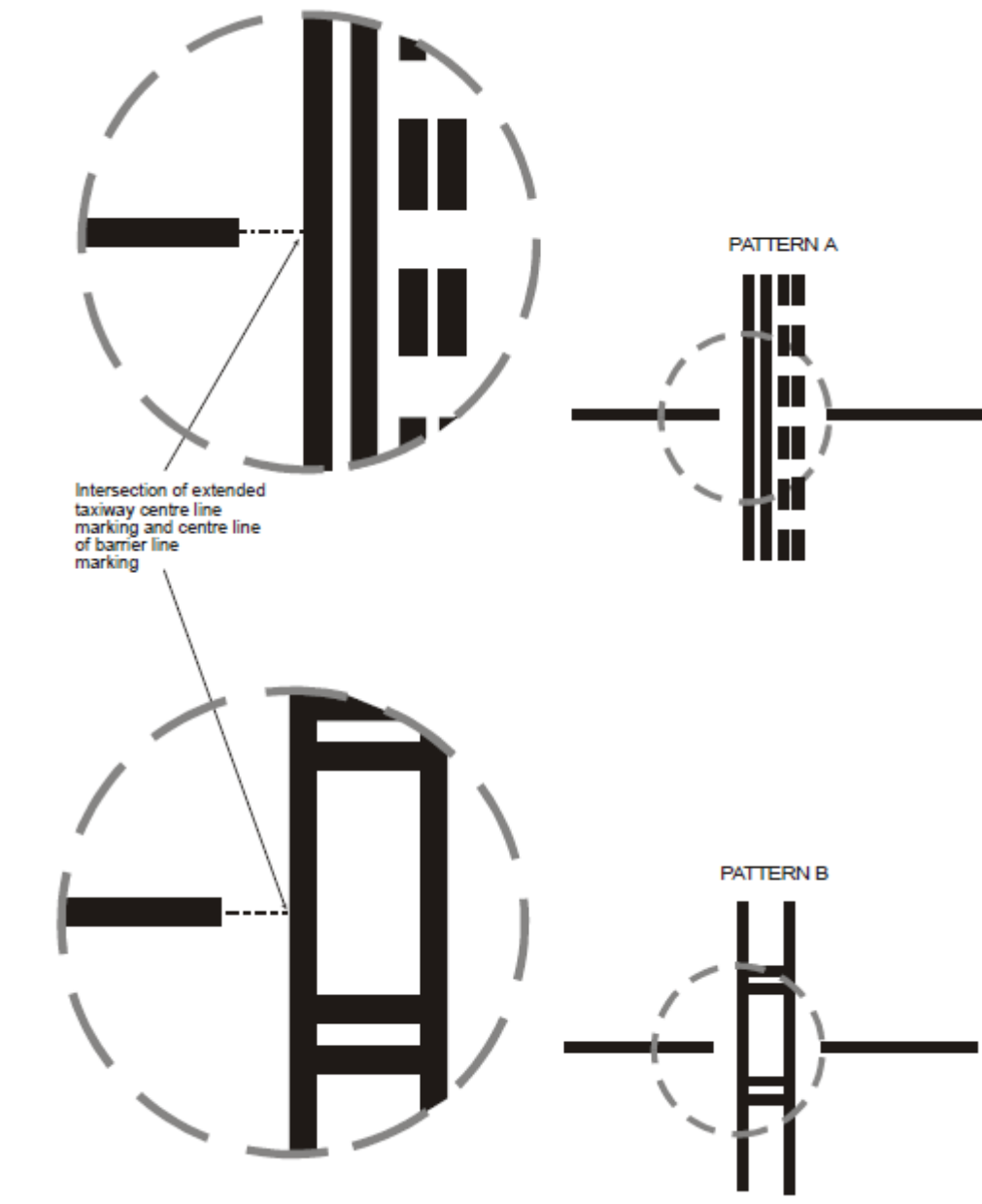

Figure 6 - Runway holding positions to be surveyed

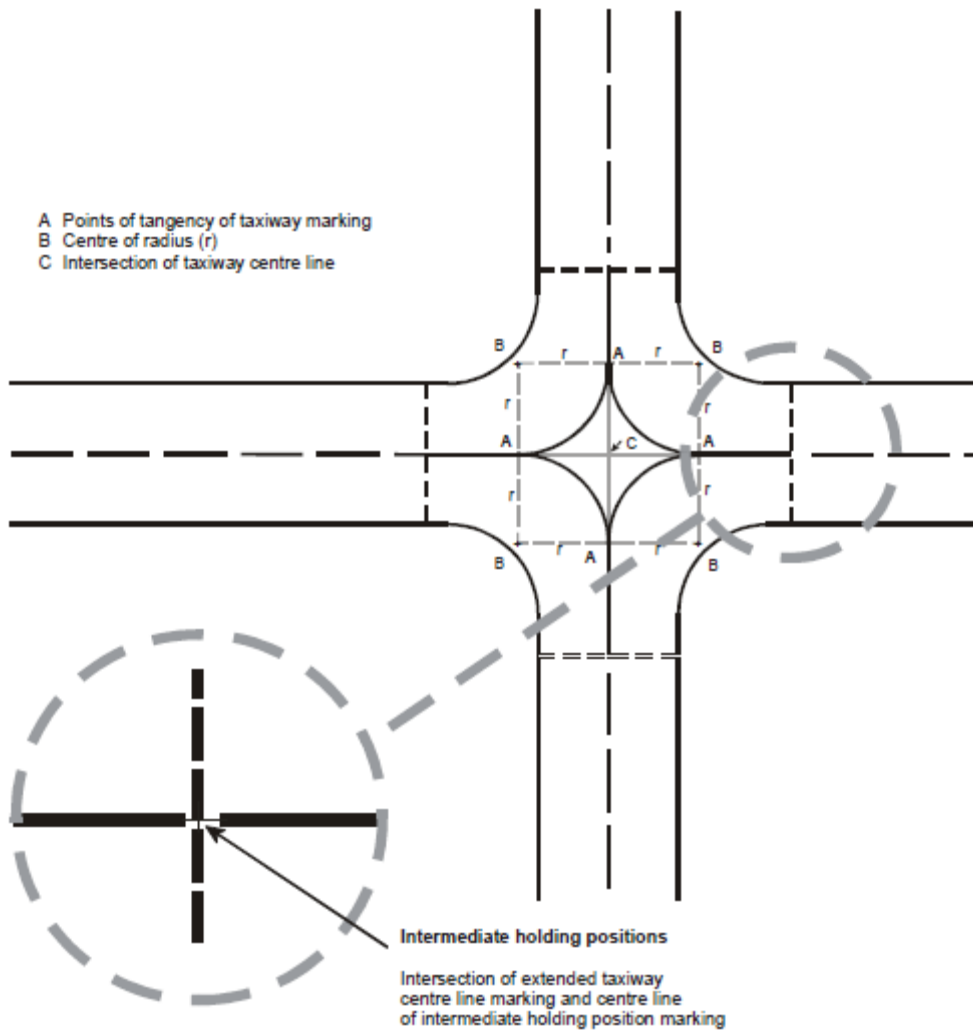

Figure 7 - Taxiway intersections to be surveyed

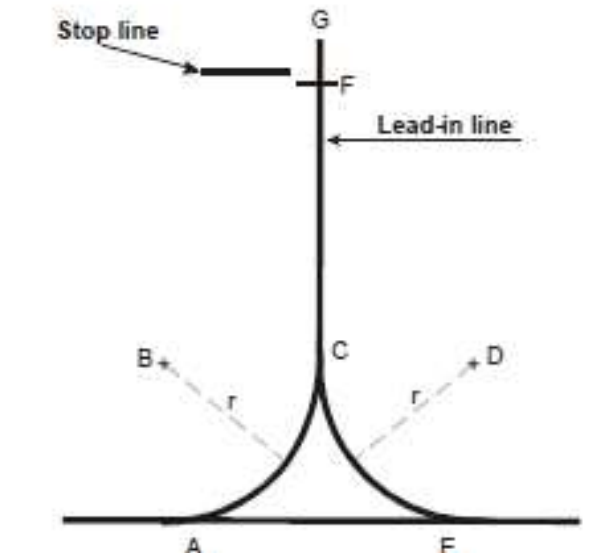

Figure 8 - Simple nose wheel lead-in line

<u>Position</u>	<u>Description of point to be surveyed</u>
<u>A</u>	<u>Point of tangency of centre of lead-in marking with centre of taxilane marking</u>
<u>B</u>	<u>Centre of arc of lead-in line and radius</u>
<u>C</u>	<u>Point of tangency with centre of lead-in line marking</u>
<u>D</u>	<u>Centre of arc of lead-in line and radius</u>
<u>E</u>	<u>Point of tangency of centre of lead-in marking with centre of taxilane marking</u>
<u>F</u>	<u>Nose wheel position of parked aircraft</u>
<u>G</u>	<u>End of lead-in line marking</u>

Table 1

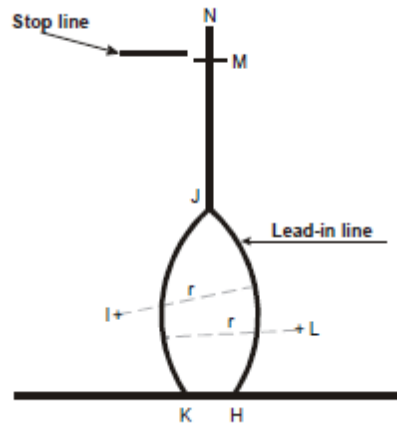

Figure 9 - Offset nose wheel lead-in line

Position	Description of point to be surveyed
H	Intersection of centre of lead-in line marking and centre of taxilane marking
I	Centre of arc of lead-in line and radius
J	Centre of commencement of straight section of lead-in line
K	Intersection of centre of lead-in line marking and centre of taxilane marking
L	Centre of arc lead-in line and radius
M	Nosewheel position of parked aircraft
N	End of lead-in line marking

Table 2-

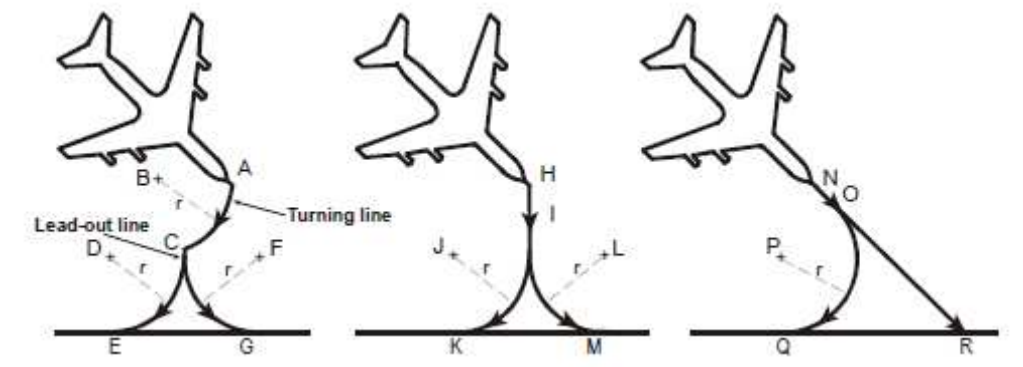

Figure 10 - Simple nose wheel lead-out lines

Position	Description of point to be surveyed
A	Centre of commencement of turning line marking

<u>B</u>	<u>Centre of arc of turning line and radius</u>
<u>C</u>	<u>Centre of intersection of turning line marking and lead-out line marking</u>
<u>D</u>	<u>Centre of arc of lead-out line and radius</u>
<u>E</u>	<u>Point of tangency of centre of lead-out line marking and taxilane marking</u>
<u>F</u>	<u>Centre of arc of lead-out line and radius</u>
<u>G</u>	<u>Point of tangency of centre of lead-out line marking and taxilane marking</u>
<u>H</u>	<u>Commencement of lead-out line</u>
<u>I</u>	<u>Centre of commencement of curved section of lead-out line</u>
<u>J</u>	<u>Centre of arc of lead-out line and radius</u>
<u>K</u>	<u>Point of tangency of centre of lead-out line marking and taxilane marking</u>
<u>L</u>	<u>Centre of arc of lead-out line and radius</u>
<u>M</u>	<u>Point of tangency of centre of lead-out line marking and taxilane marking</u>
<u>N</u>	<u>Point of tangency of centre of lead-out line marking and taxilane marking</u>
<u>O</u>	<u>Centre of commencement of curved section of lead-out line</u>
<u>P</u>	<u>Centre of arc of lead-out line and radius</u>
<u>Q</u>	<u>Point of tangency of centre of lead-out line marking and taxilane marking</u>
<u>R</u>	<u>Intersection of centre of lead-out line marking and taxilane marking</u>

Table 3

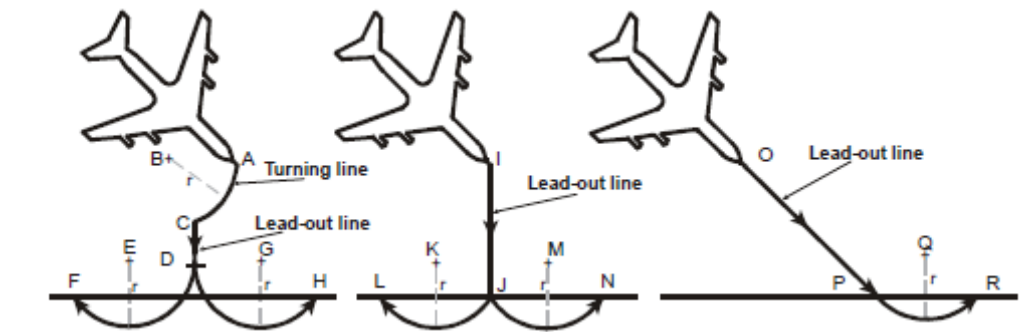

Figure 11 - Offset nose wheel lead-out lines

Position	Description of point to be surveyed
A	Centre of commencement of turning line marking
B	Centre of arc of turning line and radius
C	Centre of intersection of turning line marking and lead-out line marking
D	Centre of end of straight section of lead-out line marking
E	Centre of arc of lead-out line and radius
F	Intersection of centre of lead-out line marking and taxilane marking
G	Centre of arc of lead-out line and radius
H	Intersection of centre of lead-out line marking and taxilane marking
I	Commencement of lead-out line
J	Centre of commencement of curved section of lead-out line
K	Centre of arc of lead-out line and radius
L	Intersection of centre of lead-out line marking and taxilane marking
M	Centre of arc of lead-out line and radius
N	Intersection of centre of lead-out line marking and taxilane marking
O	Commencement of lead-out line
P	Centre of commencement of curved section of lead-out line
Q	Centre of arc of lead-out line and radius
R	Intersection of centre of lead-out line marking and taxilane marking

Table 4

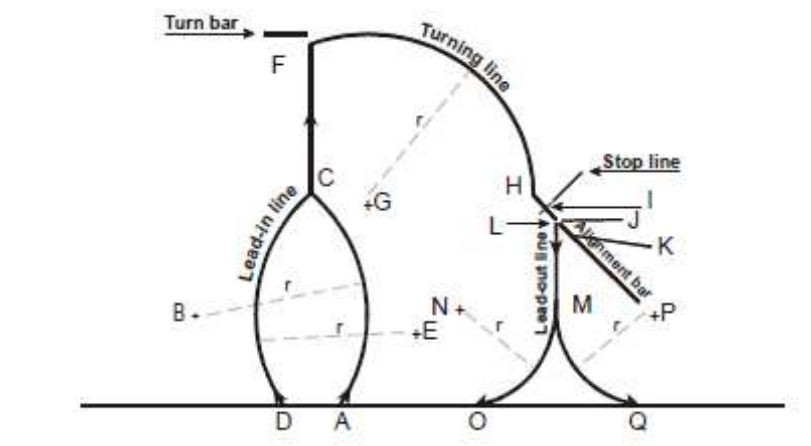

Figure 12 - Turning lines

<u>Position</u>	<u>Description of point to be surveyed</u>
<u>A</u>	<u>Intersection of centre of lead-in line marking and centre of taxilane marking</u>
<u>B</u>	<u>Centre of arc of lead-in line and radius</u>
<u>C</u>	<u>Centre of commencement of straight section of lead-in line</u>
<u>D</u>	<u>Intersection of centre of lead-in line marking and centre of taxilane marking</u>
<u>E</u>	<u>Centre of arc of lead-in line and radius</u>
<u>F</u>	<u>End of straight section of lead-in line marking/commencement of turning line marking</u>
<u>G</u>	<u>Centre of arc of turning line and radius</u>
<u>H</u>	<u>Centre of commencement of straight section of turning line marking</u>
<u>I</u>	<u>Nose wheel position of parked aircraft</u>
<u>J</u>	<u>Centre of end of straight section or turning line marking</u>
<u>K</u>	<u>True bearing of alignment bar</u>
<u>L</u>	<u>Commencement of lead-out line</u>
<u>M</u>	<u>Centre of commencement of curved section of lead-out line</u>
<u>N</u>	<u>Centre of arc of lead-out line and radius</u>
<u>O</u>	<u>Point of tangency of centre of lead-out line marking and taxilane marking</u>
<u>P</u>	<u>Centre of arc of lead-out line and radius</u>
<u>Q</u>	<u>Point of tangency of centre of lead-out line marking and taxilane marking</u>

Table 5

GM3 ADR.OPS.A.005 (a) Aerodrome data

FRICITION MEASURING DEVICES

A continuous friction measuring device (e.g. Skiddometer, Surface Friction Tester, Mu-meter, Runway Friction Tester or GripTester), can be used for measuring the friction values for compacted snow- and ice-covered runways. A decelerometer (e.g. Tapley Meter or Brakemeter – Dynometer) may be used on certain surface conditions, e.g. compacted snow, ice and very thin layers of dry snow. Other friction measuring devices can be used, provided they have been correlated with, at least, one of the types mentioned above. A decelerometer should not be used in loose snow or slush, as it can give misleading friction values. Other friction measuring devices can also give misleading friction values under certain combinations of contaminants and air/pavement temperature.

GM4 ADR.OPS.A.005(a) Aerodrome data

COVERAGE AREAS FOR TERRAIN AND OBSTACLE DATA PROVISION

(a) The coverage areas for sets of electronic and obstacle data should be specified as follows:

- (1) Area 1: the entire territory of the State;
- (2) Area 2: within the vicinity of an aerodrome, sub-divided as follows:
 - (i) Area 2a: a rectangular area around a runway that comprises the runway strip plus any clearway that exists;
 - (ii) Area 2b: an area extending from the ends of Area 2a in the direction of departure, with a length of 10 km and a splay of 15 per cent to each side;
 - (iii) Area 2c: an area extending outside Area 2a and Area 2b at a distance of not more than 10 km from the boundary of Area 2a; and
 - (iv) Area 2d: an area outside the Areas 2a, 2b and 2c up to a distance of 45 km from the aerodrome reference point, or to an existing TMA boundary, whichever is nearest.
- (3) Area 3: the area bordering an aerodrome movement area that extends horizontally from the edge of a runway to 90 m from the runway centre line, and 50 m from the edge of all other parts of the aerodrome movement area
- (4) The area extending 900 m prior to the runway threshold, and 60 m each side of the extended runway centre line in the direction of the approach on a precision approach runway, Category II or III;

(b) A graphical representation of the terrain data collection surfaces for Areas 1 and 2 is shown in the following figure:

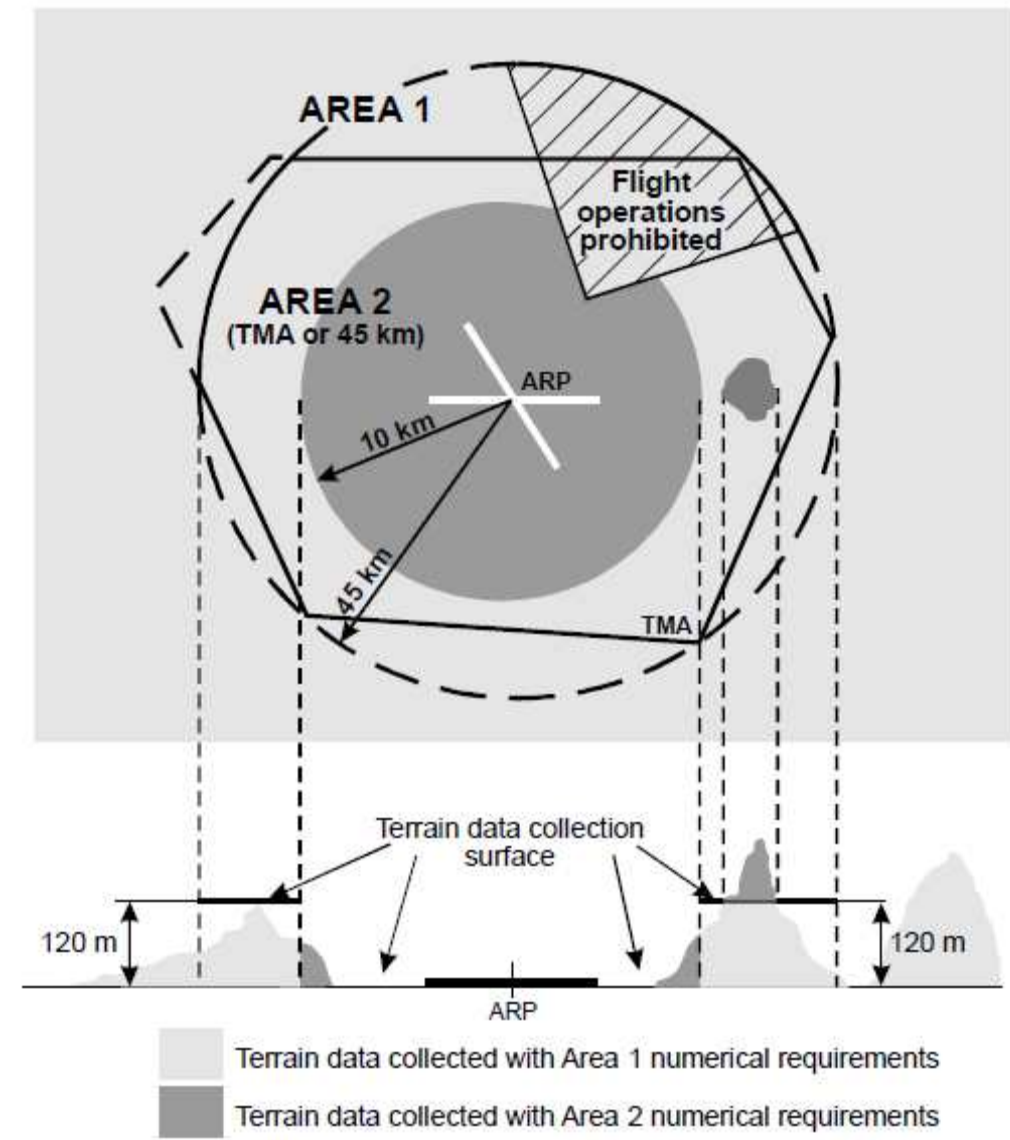

Figure 1 - Terrain data collection surfaces — Area 1 and Area 2

- (1) Within the area covered by a 10-km radius from the ARP, terrain data should comply with the Area 2 numerical requirements;
- (2) In the area between 10 km and the TMA boundary or 45-km radius (whichever is smaller), data on terrain that penetrates the horizontal plane 120 m above the lowest runway elevation, should comply with the Area 2 numerical requirements;

- (3) In the area between 10 km and the TMA boundary or 45-km radius (whichever is smaller), data on terrain that does not penetrate the horizontal plane 120 m above the lowest runway elevation, should comply with the Area 1 numerical requirements;
- (4) In those portions of Area 2 where flight operations are prohibited due to very high terrain or other local restrictions and/or regulations, terrain data should comply with the Area 1 numerical requirements.

(c) A graphical representation of the obstacle data collection surfaces for Areas 1 and 2 is shown in the following figure:

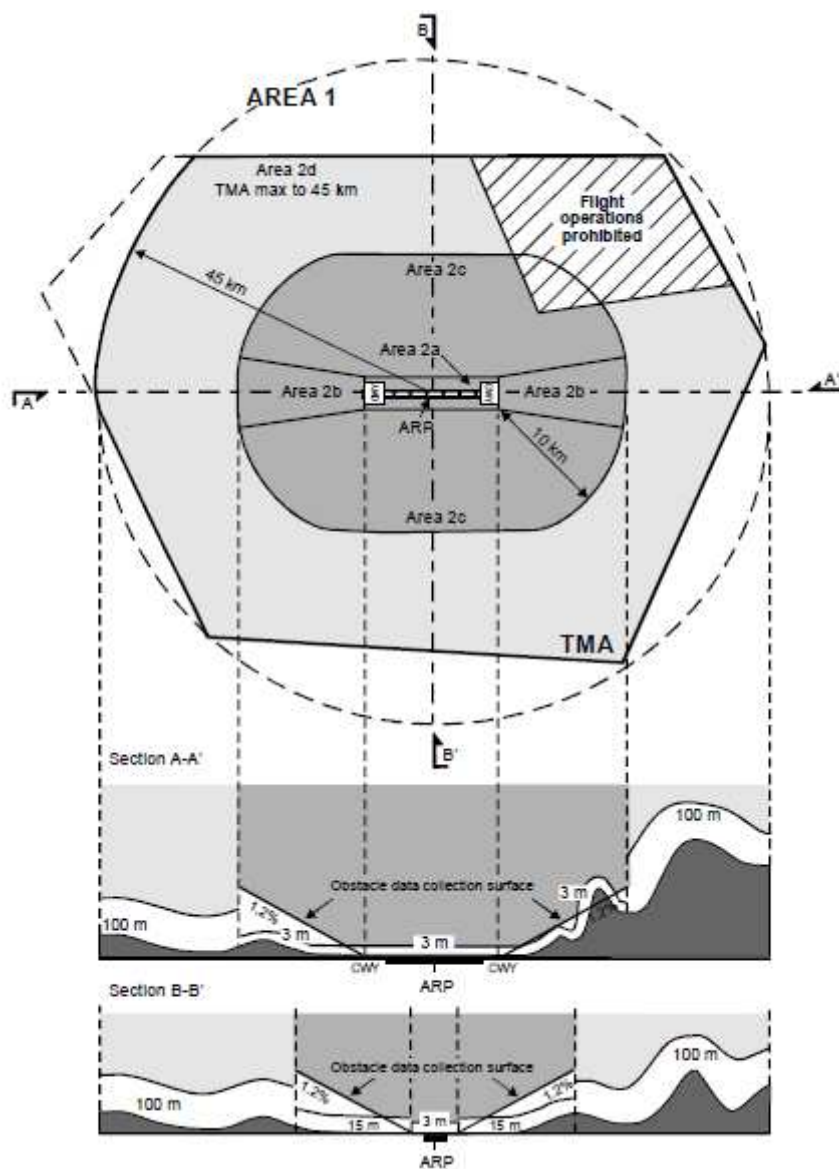

Figure 2 - Obstacle data collection surfaces – Area 1 and Area 2

(1) Obstacle data should be collected and recorded in accordance with the Area 2 numerical requirements;

(i) The Area 2a obstacle collection surface should have a height of 3 m above the nearest runway elevation measured along the runway centre line, and for those portions related to a clearway, if one exists, at the elevation of the nearest runway end;

(ii) The Area 2b obstacle collection surface has an 1.2 % slope extending from the ends of Area 2a at the elevation of the runway end in the direction of departure, with a length of 10 km and a splay of 15 % to each side;

(iii) The Area 2c collection surface has an 1.2 % slope extending outside Area 2a and Area 2b at a distance of not more than 10 km from the boundary of Area 2a. The initial elevation of Area 2c should be the elevation of the point of Area 2a at which it commences; and

(iv) The Area 2d obstacle collection surface has a height of 100 m above ground.

(2) In those portions of Area 2 where flight operations are prohibited due to very high terrain or other local restrictions and/or regulations, obstacle data should be collected and recorded in accordance with the Area 1 requirements;

(3) Data on every obstacle within Area 1 whose height above the ground is 100 m or higher should be collected and recorded in the database in accordance with the Area 1 numerical requirements specified in Table 2.

(d) A graphical representation of the terrain and obstacle data collection surfaces for Area 3 is shown in the following figure:

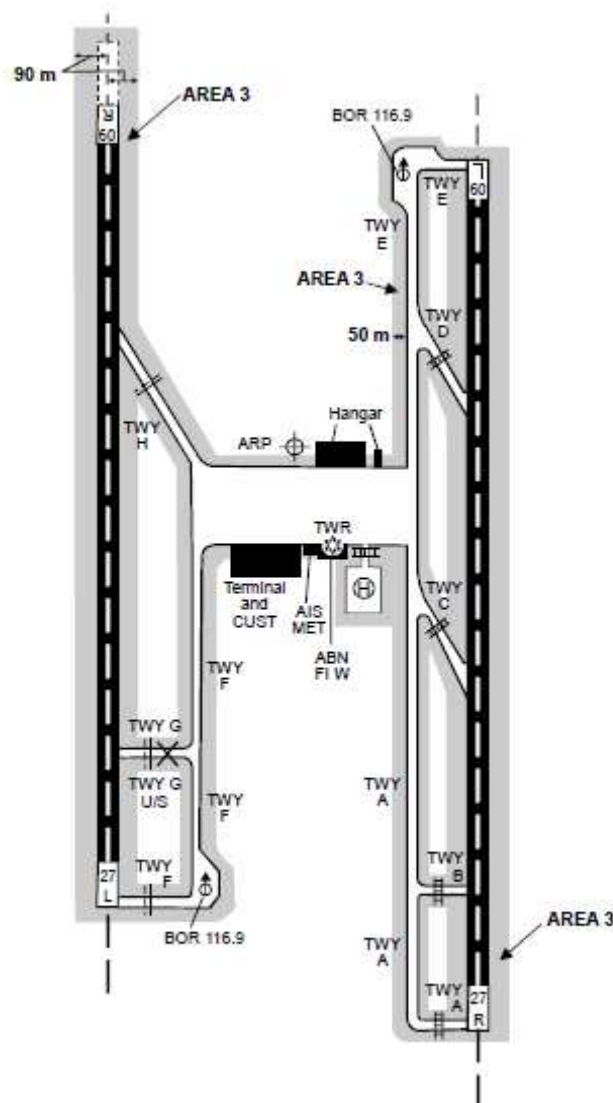

Figure 3 - Terrain and obstacle data collection surface — Area 3

- (1) The data collection surface for terrain and obstacles extends a half metre (0.5 m) above the horizontal plane passing through the nearest point on the aerodrome movement area;
- (2) Terrain and obstacle data in Area 3 should comply with the numerical requirements specified in Tables 1 and 2, respectively;

(e) A graphical representation of the obstacle data collection surfaces for Areas 4 is shown in the following figure:

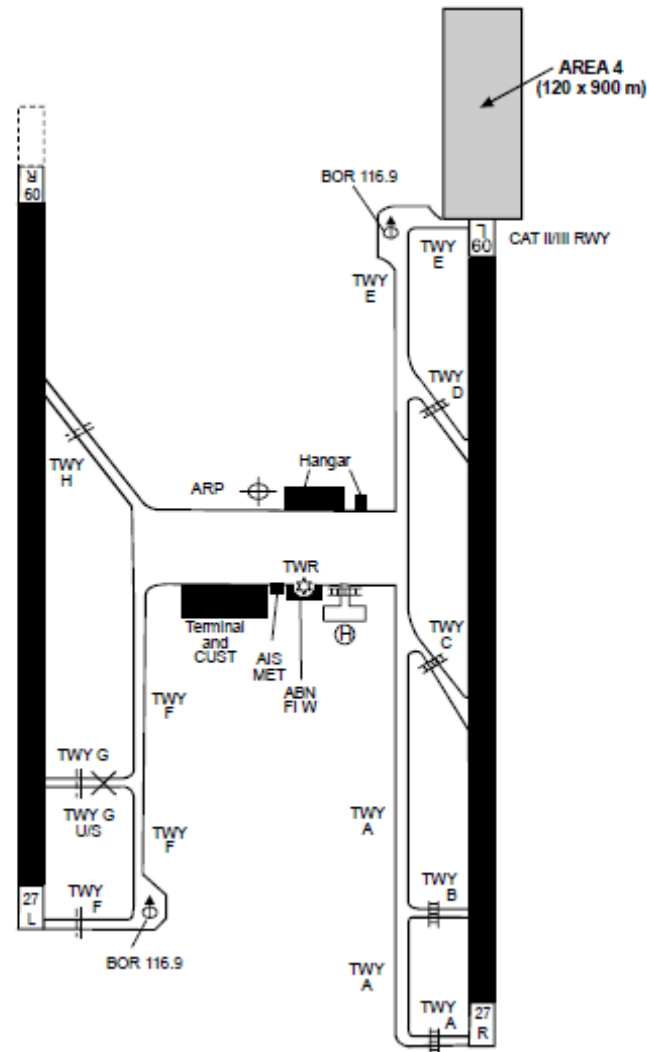

Figure 4 - Terrain and obstacle data collection surface — Area 4

- (1) Terrain data in Area 4 should comply with the numerical requirements specified in Table 1;
- (2) The horizontal extent of Area 2 covers Area 4. More detailed obstacle data may be collected in Area 4 in accordance with Area 4 numerical requirements for obstacle data specified in Table 2.
- (3) Where the terrain at a distance greater than 900 m (3000 ft) from the runway threshold is mountainous or otherwise significant, the length of Area 4 should be extended to a distance not exceeding 2000 m (6500 ft) from the runway threshold.

	Area 1	Area 2	Area 3	Area 4
Post spacing	3 arc seconds (approx. 90 m)	1 arc seconds (approx. 30 m)	0.6 arc seconds (approx. 20 m)	0.3 arc seconds (approx. 9 m)

SUBPART A – AERODROME DATA (ADR.OPS.A)

<u>Vertical accuracy</u>	<u>30 m</u>	<u>3 m</u>	<u>0.5 m</u>	<u>1 m</u>
<u>Vertical resolution</u>	<u>1 m</u>	<u>0.1 m</u>	<u>0.01 m</u>	<u>0.1 m</u>
<u>Horizontal accuracy</u>	<u>50 m</u>	<u>5 m</u>	<u>0.5 m</u>	<u>2.5 m</u>
<u>Confidence level</u>	<u>90 %</u>	<u>90 %</u>	<u>90 %</u>	<u>90 %</u>
<u>Data classification</u>	<u>Routine</u>	<u>Essential</u>	<u>Essential</u>	<u>Essential</u>
<u>Integrity level</u>	<u>1×10^{-3}</u>	<u>1×10^{-5}</u>	<u>1×10^{-5}</u>	<u>1×10^{-5}</u>
<u>Maintenance period</u>	<u>as required</u>	<u>as required</u>	<u>as required</u>	<u>as required</u>

Table 1 - Terrain data numerical requirements

	<u>Area 1</u>	<u>Area 2</u>	<u>Area 3</u>	<u>Area 4</u>
<u>Vertical accuracy</u>	<u>30 m</u>	<u>3 m</u>	<u>0.5 m</u>	<u>1 m</u>
<u>Vertical resolution</u>	<u>1 m</u>	<u>0.1 m</u>	<u>0.01 m</u>	<u>0.1 m</u>
<u>Horizontal accuracy</u>	<u>50 m</u>	<u>5 m</u>	<u>0.5 m</u>	<u>2.5 m</u>
<u>Confidence level</u>	<u>90 %</u>	<u>90 %</u>	<u>90 %</u>	<u>90 %</u>
<u>Data classification</u>	<u>Routine</u>	<u>Essential</u>	<u>Essential</u>	<u>Essential</u>
<u>Integrity level</u>	<u>1×10^{-3}</u>	<u>1×10^{-5}</u>	<u>1×10^{-5}</u>	<u>1×10^{-5}</u>
<u>Maintenance period</u>	<u>as required</u>	<u>as required</u>	<u>as required</u>	<u>as required</u>

Table 2 - Obstacle data numerical requirements

AMC1 ADR.OPS.A.010 — Data quality requirements ~~xxx~~**GENERAL REQUIREMENTS**

- (a) Aeronautical data integrity requirements should be based upon the potential risk resulting from the corruption of data and upon the use to which the data item is put. Consequently, the following classifications and data integrity levels should apply:
- (1) critical data, integrity level 1×10^{-8} : there is a high probability when using corrupted critical data that the continued safe flight and landing of an aircraft would be severely at risk with the potential for catastrophe;
 - (2) essential data, integrity level 1×10^{-5} : there is a low probability when using corrupted essential data that the continued safe flight and landing of an aircraft would be severely at risk with the potential for catastrophe; and
 - (3) routine data, integrity level 1×10^{-3} : there is a very low probability when using corrupted routine data that the continued safe flight and landing of an aircraft would be severely at risk with the potential for catastrophe.
- (b) The aerodrome operator should determine and report aerodrome-related aeronautical data in accordance with the accuracy and integrity requirements set in the following tables:

Table 3. Latitude and longitude

Latitude and longitude	Accuracy Data Type	Integrity Classification
Aerodrome reference point	30_m surveyed/calculated	1x10 ⁻³ routine
Nav aids located at the aerodrome	3_m surveyed	1x10 ⁻⁵ essential
Obstacles in Area 3	0.5_m surveyed	1x10 ⁻⁵ essential
Obstacles in Area 2 (the part within the aerodrome boundary)	5_m surveyed	1x10 ⁻⁵ essential
Runway thresholds	1_m surveyed	1x10 ⁻⁸ critical
Runway end (flight path alignment point)	1_m surveyed	1x10 ⁻⁸ critical
Runway centre line points	1_m surveyed	1x10 ⁻⁸ critical
Runway-holding position	0.5_m surveyed	1x10 ⁻⁸ critical
Taxiway centre line/parking guidance line points	0.5_m surveyed	1x10 ⁻⁵ essential
Taxiway intersection marking line	0.5_m surveyed	1x10 ⁻⁵ essential
Exit guidance line	0.5_m surveyed	1x10 ⁻⁵ essential
Apron boundaries (polygon)	1_m surveyed	1x10 ⁻³ Routine
De-icing/anti-icing facility (polygon)	1_m surveyed	1x10 ⁻³ Routine
Aircraft stand points/INS checkpoints	0.5_m surveyed	1x10 ⁻³ Routine

Table 4. Elevation/altitude/height

Table 1 – Latitude and longitude

SUBPART A – AERODROME DATA (ADR.OPS.A)

Elevation/altitude/height	Accuracy data type	Integrity classification
Aerodrome elevation	0.5- <u>m</u> surveyed	1×10^{-5} essential
WGS-84 geoid undulation at aerodrome elevation position	0.5- <u>m</u> surveyed	1×10^{-5} essential
Runway threshold, non-precision approaches	0.5- <u>m</u> surveyed	1×10^{-5} essential
WGS-84 geoid undulation at runway threshold, non-precision approaches	0.5- <u>m</u> surveyed	1×10^{-5} essential
Runway threshold, precision approaches	0.25- <u>m</u> surveyed	1×10^{-8} critical
WGS-84 geoid undulation at runway threshold, precision approaches	0.25- <u>m</u> surveyed	1×10^{-8} critical
Runway centre line points	0.25- <u>m</u> surveyed	1×10^{-8} critical
Taxiway centre line/parking guidance line points	1- <u>m</u> surveyed	1×10^{-5} essential
Obstacles in Area 2 (the part within the aerodrome boundary)	3- <u>m</u> surveyed	1×10^{-5} essential
Obstacles in Area 3	0.5 m surveyed	1×10^{-5} essential
Distance measuring equipment/precision (DME/P)	3- <u>m</u> surveyed	1×10^{-5} essential

Table 5. Declination and magnetic variation

Table 2 – Elevation/Altitude/Height

Declination/variation	Accuracy data type	Integrity classification
Aerodrome magnetic variation	1 degree surveyed	1x10 ⁻⁵ essential
ILS localizer antenna magnetic variation	1 degree surveyed	1x10 ⁻⁵ essential
MLS azimuth antenna magnetic variation	1 degree surveyed	1x10 ⁻⁵ essential

Table 6. BearingTable 3 – Declination and magnetic variation

Bearing	Accuracy data type	Integrity classification
ILS localizer alignment	1/100 degree surveyed	1x10 ⁻⁵ essential
MLS zero azimuth alignment	1/100 degree surveyed	1x10 ⁻⁵ essential
Runway bearing (True)	1/100 degree surveyed	1x10 ⁻³ routine

Table 7. Length/distance/dimensionTable 4 - Bearing

Length/distance/dimension	Accuracy data type	Integrity classification
Runway length	1_m surveyed	1x10 ⁻⁸ critical
Runway width	1_m surveyed	1x10 ⁻⁵ essential
Displaced threshold distance	1_m surveyed	1x10 ⁻³ routine
Stopway length and width	1_m surveyed	1x10 ⁻⁸ critical
Clearway length and width	1_m surveyed	1x10 ⁻⁵ essential

Landing distance available	1_m surveyed	1x10 ⁻⁸ critical
Take-off run available	1_m surveyed	1x10 ⁻⁸ critical
Take-off distance available	1_m surveyed	1x10 ⁻⁸ critical
Accelerate-stop distance available	1_m surveyed	1x10 ⁻⁸ critical
Runway shoulder width	1_m surveyed	1x10 ⁻⁵ essential
Taxiway width	1_m surveyed	1x10 ⁻⁵ essential
Taxiway shoulder width	1_m surveyed	1x10 ⁻⁵ essential
ILS localizer antenna-runway end, distance	3_m calculated	1x10 ⁻³ routine
ILS glide slope antenna-threshold, distance along centre line	3_m calculated	1x10 ⁻³ routine
ILS marker-threshold distance	3_m calculated	1x10 ⁻⁵ essential
ILS DME antenna-threshold, distance along centre line	3_m calculated	1x10 ⁻⁵ essential
MLS azimuth antenna-runway end, distance	3_m calculated	1x10 ⁻³ routine
MLS elevation antenna-threshold, distance along centre line	3_m calculated	1x10 ⁻³ routine
MLS DME/P antenna-threshold, distance along centre line	3_m calculated	1x10 ⁻⁵ essential

Table 5 – Length/distance/dimension

- (c) Accuracy requirements for aeronautical data should be based upon a 95% confidence level and, in that respect, three types of positional data should be identified: surveyed points (e.g. runway threshold), calculated points (mathematical calculations from the known surveyed points of points in space, fixes) and declared points (e.g. flight information region boundary points).

SUBPART A – AERODROME DATA (ADR.OPS.A)

- (d) Geographical coordinates indicating latitude and longitude should be determined and reported to the aeronautical information services in terms of the World Geodetic System— 1984 (WGS-84) geodetic reference datum, identifying those geographical coordinates which have been transformed into WGS-84 coordinates by mathematical means, and whose accuracy of original field work does not meet the requirements in Table-3.
- (e) The order of accuracy of the field work should be such that the resulting operational navigation data for the phases of flight will be within the maximum deviations, with respect to an appropriate reference frame, as indicated in the Tables 3-7.
- (f) In addition to the elevation (referenced to mean sea level) of the specific surveyed ground positions at aerodromes, geoid undulation (referenced to the WGS-84 ellipsoid) for those positions as indicated in Tables 3-7, should be determined and reported to the aeronautical information services authority.
- (g) Protection of electronic aeronautical data while stored or in transit, should be totally monitored by the cyclic redundancy check (CRC). To achieve protection of the integrity level of critical and essential aeronautical data as classified in (a)(1) and (a)(2) above, a 32- or 24-bit CRC algorithm should apply respectively.
- (h) To achieve protection of the integrity level of routine aeronautical data as classified in (a)(3) above, a 16-bit CRC algorithm should apply.
- (i) The aerodrome operator should implement the procedures to:
- (1) monitor data relevant to the aerodrome and available services originating from the aerodrome operator and promulgated by the relevant ANSair traffic services providers;
 - (2) notify the relevant AISaeronautical information services, and ANSair traffic services providers of any changes necessary to ensure correct and complete data relevant to the aerodrome and available services.

AMC-AMC2 ADR-OPS.A.010 Data quality requirementFORMAL ARRANGEMENTS(a) Organisations concerned

The aerodrome operator should have formal arrangements with public or private entities providing:

- (1) air navigation services;
 - (2) services for the origination and provision of survey data;
 - (3) procedure design services;
 - (4) electronic terrain data; and
 - (5) electronic obstacle data,
- with which it exchanges aeronautical data and/or aeronautical information.

(b) Content of formal arrangements

Such formal arrangements should include the following minimum content:

- (1) the scope of aeronautical data or aeronautical information to be provided;
- (2) the accuracy, resolution, and integrity requirements for each data item supplied;
- (3) the required methods for demonstrating that the data provided conforms with the specified requirements;
- (4) the nature of action to be taken in the event of discovery of a data error, or inconsistency in any data provided;
- (5) the following minimum criteria for notification of data changes:
 - (i) criteria for determining the timeliness of data provision based on the operational or safety significance of the change;
 - (ii) any prior notice of expected changes;
 - (iii) the means to be adopted for notification;
- (6) the party responsible for documenting data changes;
- (7) the means to resolve any potential ambiguities caused where different formats are used to exchange aeronautical data or aeronautical information;
- (8) any limitations on the use of data;
- (9) requirements for the production of quality reports by data providers to facilitate verification of data quality by the data users;
- (10) metadata requirements; and
- (11) contingency requirements concerning the continuity of data provision.

AMC1 ADR.OPS.A.015 — Coordination between ~~Aeronautical Information Services Providers, ANSPs and Aerodrome Operators~~^{FXT-REV} aeronautical information services, air traffic services

REPORTING

- (a) The aerodrome operator should report on matters of operational significance or affecting aircraft and aerodrome operations in order to take appropriate action, particularly in respect of the following:
- (1) construction or maintenance work;
 - (2) rough or broken surfaces on a runway, a taxiway_x or an apron;
 - (3) snow, slush, ice, wet ice, wet snow on ice_x or frost on a runway, a taxiway_x or an apron;
 - (4) water on a runway, a taxiway_x or an apron;
 - (5) snow banks or drifts adjacent to a runway, a taxiway_x or an apron;
 - (6) anti-icing or de-icing liquid chemicals_x or other contaminants on a runway, a taxiway_x or an apron;
 - (7) other temporary hazards, including parked aircraft;
 - (8) failure or irregular operation of part or all of the aerodrome visual aids; and

(9) failure of the normal or secondary power supply^{7.1}.

~~(10) changes to the disabled aircraft removal;~~

~~(11) changes to visual approach slope indicator system.~~

- (b) ~~The aerodrome operator should notify the changes~~ A change in the level of protection normally available at an aerodrome for rescue and ~~fire-fighting to the appropriate ANSPs~~ firefighting should be expressed in terms of the new category available at the aerodrome. When such a change has been corrected, the air traffic services provider and the aeronautical information services providers ~~to enable them to provide the necessary information to arriving and departing aircraft. When such a change has been corrected, the above units shall~~ should be advised accordingly^{7.1}.
- (c) The aerodrome operator should observe the predetermined, internationally agreed AIRAC effective dates in addition to 14 ~~days-day~~ postage time when submitting the raw information/data to aeronautical information services that affect charts and/or computer-based navigation systems which qualify to be notified by the aeronautical information regulation and control (AIRAC) system.

SUBPART B – AERODROME OPERATIONAL SERVICES, EQUIPMENT, AND INSTALLATIONS

GM1 ADR.OPS.B.001 Provision of operational services

SERVICES

The services included in Part B of this Annex, need to be provided at an aerodrome. In some cases, these services are not directly provided by the aerodrome operator, but by another organisation or State entity. However, the aerodrome operator, being responsible for the operation of the aerodrome should have arrangements and interfaces with these organisations or entities to ensure the provision of services according to the legal requirements. The method described above meets with the intention of an integrated Safety Management System that helps the aerodrome operator to ensure the safety objective of the service provision.

AMC1-~~ADR-~~OPS.B.005 – Aerodrome Emergency Planning ~~TXF~~

~~(a) The aerodrome emergency plan of the operator should observe human factors principles to ensure optimum response in emergency operations;~~

GENERAL

~~(b)~~(a) The aerodrome operator should ensure that the plan includes the ready availability of, and coordination with, appropriate specialist rescue services to be able to respond to emergencies where an aerodrome is located close to water and/or swampy areas, and where a significant portion of approach or departure operations takes place over these areas.

(b) The aerodrome operator should ensure that an assessment of the approach and departure areas within 1000 m of the runway threshold is carried out to determine the options available for intervention.

AMC2-~~ADR-~~OPS.B.005 – Aerodrome Emergency ~~Plan Document~~ ~~TXF-REV~~ Planning

AERODROME EMERGENCY PLAN DOCUMENT

The aerodrome operator should include, at least, the following in the aerodrome emergency plan document:

- (a) Types of emergencies planned for;
- (b) Agencies involved in the plan, and details of the aerodrome and local emergency planning arrangements and forums;
- (c) Responsibility and role of each agency, the emergency operations centre, and the command post for each type of emergency;
- (d) Information on names and telephone numbers of offices or people to be contacted in the case of a particular emergency; and
- (e) A grid map of the aerodrome and its immediate vicinity surroundings, approximately at a distance of 5 nautical miles (8 km) from the centre of the aerodrome.

CRD to NPA 2011-20 (B.II)

09/12/201126

AMC/GM to Annex III – Part-OPS

Nov 2012

*SUBPART B – AERODROME OPERATIONAL SERVICES, EQUIPMENT AND
INSTALLATIONS (ADR.OPS.B)*

SUBPART B – AERODROME OPERATIONAL SERVICES, EQUIPMENT AND INSTALLATIONS (ADR.OPS.B)

AMC3-~~ADR-~~OPS.B.005 – Aerodrome emergency ~~exercise~~^{FXT-REV} planningAERODROME EMERGENCY EXERCISE

The aerodrome operator should ensure that the emergency plan is tested ~~by conducting~~with:

- (a) a full-scale aerodrome emergency exercise at intervals not exceeding two years; and
- (b) partial emergency exercises in the intervening year to ensure that any deficiencies found during the full-scale aerodrome emergency exercise have been corrected;

and reviewed thereafter, or after an actual emergency, so as to correct any deficiency found during such exercises or actual emergency; ~~(we have to check with R1 responses to SL).~~

GM1-~~ADR-~~OPS.B.005 – ~~Purpose of the~~ Aerodrome ~~Emergency Plan~~ emergency planning

~~(a) The purpose of the aerodrome emergency plan is to ensure that there is:~~

PURPOSE OF THE AERODROME EMERGENCY PLAN

- (a) In many cases the aerodrome emergency plan is part of a National or Local Emergency Plan, and the responsibility for its development is assigned to another entity, different from the aerodrome operator. However, this does not prevent the aerodrome operator from preparing its own plan describing the actions that should be taken during an emergency, in cooperation with the authorities which are responsible for the National or Local Emergency Plan.
- (b) The aerodrome emergency plan should cover an area of approximately 5 nautical miles (8 km) from the centre of the aerodrome.
- (c) Irrespective of whose responsibility is the establishment and implementation of an emergency plan covering emergencies at or in the surroundings of an aerodrome, the emergency plan should ensure that there are provisions for:
 - (1) orderly and efficient transition from normal to emergency operations;
 - (2) delegation of ~~airport emergency~~ authority;
 - (3) assignment of emergency responsibilities;
 - (4) ~~authorisation by~~ authorising key personnel for actions contained in the plan;
 - (5) ~~co-ordination~~ coordination of efforts to cope with the emergency; and
 - (6) safe continuation of aircraft operations or return to normal operations as soon as possible.

GM2-~~ADR-~~OPS.B.005 – ~~Coordination with other agencies~~ Aerodrome emergency planningCOORDINATION WITH OTHER AGENCIES ORGANISATIONS

SUBPART B – AERODROME OPERATIONAL SERVICES, EQUIPMENT AND INSTALLATIONS (ADR.OPS.B)

- (a) The aerodrome emergency plan ~~establishes~~should describe the procedures for coordinating the response of different aerodrome agencies ~~{organisations or services (e.g. ground handlers, airlines, security services)}~~ and those agencies in the surrounding community that could be of assistance in responding to an emergency~~;~~.
- (b) ~~Coordination of~~If the aerodrome emergency plan ~~with the surrounding community~~ is not part of a National or Local Emergency Plan, then it should be coordinated as required~~;~~.
- (c) Emergency mutual aid agreements ~~are necessary~~should be established to define responsibilities and/or liabilities of each ~~contributing party with surrounding communities~~external agency responding to an emergency. These agreements ~~could~~should include the following:
- (1) clarification of the political and jurisdictional responsibilities of the several agencies ~~that may (e.g. police, local fire fighting services, local authorities, accident investigation bodies, etc.) that could~~ be involved in order to avoid problems when an emergency occurs;
 - (2) establishment of the command authority; i.e. a single on-the-scene commander (with designated alternates if necessary);
 - (3) designation of communication priorities at the accident site;
 - (4) organisation of emergency transportation facilities under (a) pre-designated coordinator(s);
 - (5) predetermination of the legal authorities and liabilities of all cooperating emergency personnel; and
 - (6) ~~prearrangements~~pre-arrangements for use of portable and heavy rescue equipment from available sources.
- (d) The aerodrome emergency plan ~~is~~should be implemented similarly whether it is an on-airport or an off-airport aircraft accident/incident.
- (e) Rendezvous signs and directional arrows should be consistent, and conform to national standards.
- (f) The aerodrome operator should assess the level of medical supplies to be held on the aerodrome for emergency purposes.

GM3-ADR-OPS.B.005 — ~~Command during emergencies~~ Aerodrome emergency planning

~~In an on-airport aircraft accident/incident the~~AERODROME EMERGENCY PLAN DOCUMENT

- ~~(a) The~~ aerodrome operator is normally in command;
- ~~(b) In an off-airport aircraft accident/incident, the agency in command will be the agency agreed upon in the mutual aid emergency agreement between~~plan of the aerodrome operator ~~and the surrounding community.~~

SUBPART B – AERODROME OPERATIONAL SERVICES, EQUIPMENT AND
INSTALLATIONS (ADR.OPS.B)

- (a) ~~When an aircraft accident/incident occurs just outside the aerodrome perimeter, the jurisdictional responsibility will be as agreed upon in the mutual aid emergency agreement between the aerodrome operator and the surrounding community. This, however, should not affect the immediate~~should observe human factors principles to ensure optimum response by aerodrome personnel or by agencies having roles in the aerodrome emergency plan operations.

GM4 ADR-OPS.B.005 — Aerodrome Emergency Plan Document

- (b) ~~The~~In order to ensure that the aerodrome emergency plan document, ~~may fully serves its purpose, it should~~ include the following:
- (1) plans for dealing with emergencies occurring at the aerodrome or in its ~~vicinity~~surroundings, including the malfunction of aircraft in flight; structural fires; sabotage, including bomb threats (aircraft or structure); unlawful seizure of aircraft; and incidents on the airport covering 'during the emergency' and 'after the emergency' considerations;
 - (2) details of tests for aerodrome facilities and equipment to be used in emergencies, such as emergency operations centre, mobile command post, fire fighting vehicles and equipment, communication means, first aid medical supplies, etc., including the frequency of those tests;
 - (3) details of exercises to test emergency plans, including the frequency of those exercises;
 - (4) a list of organisations, agencies, and persons of authority, both on and off-airport, for site roles; their telephone and ~~facsimile~~fax numbers, e-mail and SITA addresses, and the radio frequencies of their offices;
 - (5) the establishment of an aerodrome emergency committee to ~~organize~~organise training and other preparations for dealing with emergencies; ~~and~~
 - (6) the appointment of an on-~~the~~-scene commander for the overall emergency operation; ~~and~~
 - (7) ~~GM5~~Details of the off aerodrome areas for which the aerodrome RFFS will provide a response, and the size and nature of the response.

GM4 ADR-OPS.B.005 — Contents of an Aerodrome emergency planning

CONTENTS OF AN AERODROME EMERGENCY PLAN DOCUMENT

The purpose of the aerodrome Emergency Plan Document

Theis to provide all the required information to agencies and staff involved in an emergency. The document should be structured in such a manner, that the required information is easily identifiable. For that purpose, the structure of the aerodrome emergency plan may~~should~~ be as follows:

Section 1 – Emergency telephone numbers

This section ~~is~~ should be limited to essential telephone numbers according to the aerodrome needs, including:

- (a) air traffic services unit;
- (b) rescue and ~~fire-fighting~~ firefighting services (fire departments);
- (c) airfield operations department;
- ~~(e)~~(d) police and security;
- ~~(d)~~(e) medical services:
 - (1) —hospitals;
 - (2) —ambulances; and
 - (3) —doctors — business/residence;
- ~~(e)~~(f) aircraft operators;
- ~~(f)~~(g) ground handling agencies;
- ~~(g)~~(h) government authorities;
- ~~(h)~~(i) civil defence; and
- ~~(i)~~(j) others.

Section 2 – Aircraft accident on the airport

- (a) ~~action~~ Action by air traffic services ~~(airport control tower or airport flight information service)~~; unit;
- (b) ~~action~~ Action by rescue and ~~fire-fighting~~ firefighting services;
- (c) ~~action~~ Action by police and security services;
- (d) ~~action~~ Action by the aerodrome operator:
 - (1) —vehicle escort; and
 - (2) —maintenance;
- (e) ~~action~~ Action by medical services:
 - (1) —hospitals;
 - (2) —ambulances;
 - (3) —doctors; and
 - (4) —medical personnel.
- (f) ~~action~~ Action by aircraft operator involved;
- (g) ~~action~~ Action by emergency operations centre and mobile command post;

- (h) ~~action~~Action by government authorities;
- (i) ~~communication~~Communication network (emergency operations centre and mobile command post);
- (j) ~~action~~Action by agencies organisations involved in mutual aid emergency agreements;
- (k) ~~action~~Action by transportation authorities (land, sea, air);
- (l) ~~action~~Action by public information officer(s);
- (m) ~~action~~Action by local fire departments when structures involved; and
- (n) ~~action~~Action by all other agencies.

Section 3 – Aircraft accident off the airport

- (a) ~~action~~Action by air traffic services (~~airport control tower or airport flight information service~~);unit;
- (b) ~~action~~Action by rescue and ~~fire-fighting~~firefighting services;
- (c) ~~action~~Action by local fire departments;
- (d) ~~action~~Action by police and security services;
- (e) ~~action~~Action by aerodrome operator;
- (f) ~~action~~Action by medical services;
 - (i) hospitals;
 - (ii) ambulances;
 - (iii) doctors; and
 - (iv) medical personnel.
- (g) ~~action~~Action by agencies involved in mutual aid emergency agreements;
- (h) ~~action~~Action by aircraft operator involved;
- (i) ~~action~~Action by emergency operations centre and mobile command post;
- (j) ~~action~~Action by government authorities;
- (k) ~~action~~Action by communication networks (emergency operations centre and mobile command post);
- (l) ~~action~~Action by transportation authorities (land, sea, air);
- (m) ~~action~~Action by public information officer; and
- (n) ~~action~~Action by all other agencies.

Section 4 – Malfunction of aircraft in flight (Full emergency or local standby)

- (a) ~~action~~Action by air traffic services (~~airport control tower or flight information service~~);unit;
- (b) ~~action~~Action by airport rescue and ~~fire-fighting~~firefighting services;
- (c) ~~action~~Action by police and security services;
- (d) ~~action~~Action by the aerodrome operator;
- (e) ~~action~~Action by medical services:
 - (1) —hospitals;
 - (2) —ambulances;
 - (3) —doctors; and
 - (4) medical personnel.
- (f) ~~action~~Action by aircraft operator involved;
- (g) ~~action~~Action by emergency operations centre and mobile command post; and
- (h) ~~action~~Action by all other agencies.

Section 5 – Structural fires

- (a) ~~action~~Action by air traffic services (~~airport control tower or airport flight information service~~);unit;
- (b) ~~action~~Action by rescue and ~~fire-fighting~~firefighting services (local fire department);
- (c) ~~action~~Action by police and security services;
- (d) ~~action~~Action by airport authority;
- (e) ~~evacuation~~Evacuation of structure;
- (f) ~~action~~Action by medical services:
 - (1) —hospitals;
 - (2) —ambulances;
 - (3) —doctors; and
 - (4) —medical personnel.
- (g) ~~action~~Action by emergency operations centre and mobile command post;
- (h) ~~action~~Action by public information officer; and
- (i) ~~action~~Action by all other agencies.

Section 6 – Sabotage including bomb threat (aircraft or structure)

- (a) ~~action~~Action by air traffic services (~~airport control tower or airport flight information service~~);unit;

- (b) ~~action~~ Action by emergency operations centre and mobile command post;
- (c) ~~action~~ Action by police and security services;
- (d) ~~action~~ Action by the aerodrome operator;
- (e) ~~action~~ Action by rescue and ~~fire-fighting~~ firefighting services;
- (f) ~~action~~ Action by medical services:
 - (1) —hospitals;
 - (2) —ambulances;
 - (3) —doctors; and
 - (4) —medical personnel.
- (g) ~~action~~ Action by aircraft operator involved;
- (h) ~~action~~ Action by government authorities;
- (i) ~~isolated~~ Isolated aircraft parking position;
~~(1)~~—evacuation;
- (j) ~~searches~~ Evacuation;
- ~~(j)~~(k) Searches by dogs and trained personnel;
- ~~(k)~~(l) handling Handling and identification of luggage and cargo on board aircraft;
- ~~(l)~~(m) handling Handling and disposal of suspected bomb;
- ~~(m)~~(n) ~~action~~ Action by public information officer; and
- ~~(n)~~(o) ~~action~~ Action by all other agencies.

Section 7 – Unlawful seizure of aircraft

- (a) ~~action~~ Action by air traffic services ~~(airport control tower or airport flight information service);~~ unit;
- (b) ~~action~~ Action by rescue and ~~fire-fighting~~ firefighting services;
- (c) ~~action~~ Action by police and security services;
- (d) ~~action~~ Action by the aerodrome operator;
- (e) ~~action~~ Action by medical services;
 - (1) —hospitals;
 - (2) —ambulances;
 - (3) —doctors; and
 - (4) —medical personnel.
- (f) ~~action~~ Action by aircraft operator involved;

- (g) ~~action~~Action by government authorities;
- (h) ~~action~~Action by emergency operations centre and mobile command post;
- (i) ~~isolated~~Isolated aircraft parking position;
- (j) ~~action~~Action by public information officer; and
- (k) ~~action~~Action by all other agencies.

Section 8 – Incident on the airport

An incident on the airport ~~may~~could require any, or all of the actions detailed in Section 2, 'Aircraft accident on the airport'. Examples of incidents the ~~airport authority~~aerodrome operator should consider to include: fuel spills at the ramp, passenger loading bridge, and fuel storage area; dangerous goods occurrences at freight handling areas; collapse of structures; vehicle/aircraft collisions; etc.

Section 9 – Persons of authority ~~==~~ site roles

To include, but not limited to, the following, according to local requirements:

- (a) On-airport:
 - (1) Aerodrome chief fire officer;
 - (2) Airport authority;
 - (3) Police and security – Officer-in-charge; and
 - (4) Medical coordinator.
- (b) Off-airport:
 - (1) Local chief fire officer;
 - (2) Government authority; and
 - (3) Police and security – officer-in-charge.

The on-~~the~~-scene commander will be designated as required from within the pre-arranged mutual aid emergency agreement.

~~GM6-~~

GM5 ADR-OPS.B.005 —Types of Emergencies Aerodrome Emergency Planning

TYPES OF EMERGENCIES

- (a) At least the following types of emergencies may be included in the aerodrome emergency plan:
- (1) Aircraft emergencies;
 - (2) Aircraft ground incidents, where an aircraft on the ground is known to have an emergency situation other than an accident, requiring the attendance of emergency services;
 - ~~(2)(3)~~ Sabotage, including bomb threats;
 - ~~(3)(4)~~ Unlawfully seized aircraft;
 - ~~(4)(5)~~ Dangerous goods occurrences;
 - ~~(5)(6)~~ Building fires;
 - ~~(6)(7)~~ Natural disasters; and
 - ~~(7)(8)~~ Public health emergencies;
- (b) The aircraft emergencies for which services may be required are generally classified as:
- (1) 'aircraft accident': an aircraft accident which has occurred on or in the vicinity of the airport;
 - (2) 'full emergency': an aircraft approaching the airport is, or is suspected to be, in such trouble that there is imminent danger of an accident; and
 - (3) 'local standby': an aircraft approaching the airport is known, or is suspected to have developed some defect, but the trouble is not such as would normally involve any serious difficulty in effecting a safe landing.

GM7-GM6 ADR-OPS.B.005 —Involved Agencies in Emergencies Aerodrome emergency planning

INVOLVED AGENCIES IN EMERGENCIES

The following agencies ~~should~~could participate in response to an emergency, depending on the type of emergency and local arrangements:

- (a) On the aerodrome:
- (1) Air Traffic Control Unit;
 - (2) Rescue and ~~fire-fighting~~firefighting services;
 - (3) Aerodrome administration;
 - (4) Medical and ambulance services;
 - (5) Aircraft operators;
 - (6) Ground handling agencies;

SUBPART B – AERODROME OPERATIONAL SERVICES, EQUIPMENT AND INSTALLATIONS (ADR.OPS.B)

- (7) Security services; and
- (8) Police.
- (b) Off the aerodrome:
 - (1) Fire departments;
 - (2) Police;
 - (3) Health authorities (including medical, ambulance, hospital and public health services);
 - (4) Military; and
 - (5) Harbour or coast guard, if applicable.

GM8-GM7 ADR-OPS.B.005 — Emergency Operations Centre

At Aerodrome emergency planning

EMERGENCY OPERATIONS CENTRE

- (a) The practice had shown that emergencies are handled more efficiently centrally through an emergency operations centre and a command post could be available for use during an emergency;
- ~~(b)~~—The emergency operations centre maycould be a part of the aerodrome facilities, and responsible for the overall coordination and general direction of the response to an emergency;
- ~~(c)~~~~(b)~~ The command post is a facility capable of being moved rapidly to. Depending on the site of an emergency, when required, size of the aerodrome and undertakes the local coordination of those agencies responding to procedures, more than one emergency centres could be established, but within the aerodrome emergency plan should be identified which of them has the overall responsibility for coordination.
- ~~(d)~~~~(c)~~ A person mayshould be assigned to assume control of the emergency operations centre and, when appropriate, another person the command post;
- ~~(e)~~~~(d)~~ The role of the emergency operations centre isshould be to support the on-the-scene commander in the mobile command post for aircraft accidents/incidents;
- ~~(f)~~~~(e)~~ The emergency operations centre, depending on relevant security plans and local procedures could be the command, ~~co-ordination~~coordination, and communication centre for unlawful seizure of aircraft and bomb threats;
- ~~(g)~~~~(f)~~ The emergency operations centre mayshould be operationally available 24 hours a day, or during the aerodrome's hours of operation, and procedures should be established for notifying its staff.
- ~~(h)~~~~(g)~~ The efficiencylocation of the emergency ~~operations~~operation centre couldis very important for its efficiency. Consideration should be enhanced by establishing it at given

SUBPART B – AERODROME OPERATIONAL SERVICES, EQUIPMENT AND
INSTALLATIONS (ADR.OPS.B)

to establish its location having a clear view of the movement area and isolated aircraft parking position, wherever possible~~±~~.

~~(i)(h) The emergency operations centre is necessary to have adequate~~Adequate equipment and personnel should be available in order to communicate with the appropriate agencies involved in the emergency, including the mobile post, when this is deployed. The communication and electronic devices ~~may~~should be checked ~~daily~~regularly, to identify any malfunctions.

GM9-

GM8 ADR-OPS.B.005 — Mobile Command Post Aerodrome emergency planningMOBILE COMMAND POST

- (a) The command post should be a facility capable of being moved rapidly to the site of an emergency, when required, and should undertake the local coordination of those agencies responding to the emergency.
- (a)(b) The mobile command post ~~contains, when established, should contain~~ the necessary equipment and personnel to communicate with all agencies involved in the emergency, including the emergency operations centre. The communication and electronic devices ~~may~~ should be checked ~~each month regularly, in order to identify any malfunctions.~~
- (b)(c) Maps, charts, and other relevant equipment and information ~~needs to~~ should be available at the mobile command post.

GM10 — GM9 ADR-OPS.B.005 — Communication System Aerodrome emergency planningAdequate COMMUNICATION SYSTEMS USED FOR EMERGENCIES

- (a) When established, adequate communication systems linking the command post and the emergency operations centre with each other and with the participating agencies ~~may~~ should be provided in accordance with the plan, and consistent with the particular requirements of the aerodrome.
- (b) The communication systems used ~~may consist of~~ should include a sufficient number of radio transceivers, telephones, and other communication devices to establish and maintain a primary, and a secondary means of communication;
- (c) The role of the communication systems is to provide a primary, and, where necessary, an alternate means for effective direct communications between the following, as applicable:
- (1) ~~The~~ the alerting authority and the rescue and ~~fire-fighting~~ firefighting (RFF) units serving the airport;
 - (2) ~~Air~~ air traffic ~~control tower and/or flight service stations~~ services unit, the appropriate fire department alarm room/dispatch centre(s) and the ~~fire-fighting~~ firefighting and rescue crews en route to an aircraft emergency and at the accident/incident site;
 - (3) ~~Appropriate~~ appropriate mutual aid agencies located on or off the airport, including an alert procedure for all auxiliary personnel expected to respond; and
 - (4) ~~The~~ the RFF vehicles, including a communication capability between crew members on each RFF vehicle.
- (d) A communications system ~~may~~ should be established in order to provide rapid response of the emergency equipment to accidents and incidents occurring in the terminal areas, and at the apron. Apron accidents include aircraft cabin fires, refuelling spills and fires, aircraft and vehicle collisions, and medical emergencies.

SUBPART B – AERODROME OPERATIONAL SERVICES, EQUIPMENT AND INSTALLATIONS (ADR.OPS.B)

- (e) ~~It is important to test frequently the communication~~ Communication systems used during emergencies should be tested regularly to verify the operability of all radio and telephone networks~~;~~.
- (f) A complete and current list of interagency telephone numbers ~~could~~ should be available to all agencies and to personnel responsible for the aerodrome emergency plan, to ensure rapid notification in case of emergencies. These phone numbers ~~need to~~ should be verified frequently to ensure they are correct. Updated lists ~~may~~ should be distributed to all emergency plan participants on a continual basis.

GM11 – GM10 ADR OPS.B.005 – Emergencies in difficult environments Aerodrome emergency planningEMERGENCIES IN DIFFICULT ENVIRONMENT

At those aerodromes located close to water and/or swampy areas, or difficult terrain, the aerodrome emergency plan ~~may~~ should include the establishment, testing, and assessment at regular intervals of a predetermined response for the specialist rescue services.

GM12 – GM11 ADR OPS.B.005 – Emergency Exercises Aerodrome emergency planningEMERGENCY EXERCISES

- (a) Full-scale exercises
- (1) The purpose of a full-scale exercise is to ensure the adequacy of the plan to cope with different types of emergencies.
- ~~(1)~~(2) Full-scale emergency exercises ~~need to~~ should be supported by all aerodrome and community authorities concerned~~;~~.
- ~~(2)~~(3) Objectives of the exercise ~~needs to~~ should be defined~~;~~.
- ~~(3)~~(4) Involved departments and agencies ~~have to~~ should be thoroughly familiar with the airport emergency plan, and develop individual plans in coordination with the general plan~~;~~.
- ~~(4)~~(5) The emergency exercises ~~may~~ should be held in locations which will provide maximum realism while ensuring minimum disruption of the airport operations. Various Different scenarios can, as described in the aerodrome emergency plan document, should be used. The exercise ~~may~~ could be held either during the day or at night on the airport~~;~~, and at different times of the year when seasonal changes may present additional challenges. Exercises may take place both on or near the aerodrome to test different scenarios.
- ~~(5)~~(6) In order to obtain the maximum benefit from a full-scale emergency exercise, ~~it is important to review~~ the entire proceedings- should be reviewed. An observer critique team ~~could~~ should be organised, comprised of members who are familiar with mass casualty accident proceedings. Each member of the critique team

SUBPART B – AERODROME OPERATIONAL SERVICES, EQUIPMENT AND INSTALLATIONS (ADR.OPS.B)

~~observes~~observe the entire exercise, and ~~completes~~complete the appropriate emergency drill critique forms. As soon as convenient after the exercise ~~(not later than seven days),~~ a critique meeting ~~needs to~~should be held so members of the team can present their observations and recommendations for improvement of the airport emergency plan procedures and associated airport emergency plan document.

~~(6)~~(7) The exercise ~~may~~should be followed by a full debriefing, critique, and analysis. It is important that representatives of all organisations which participate in the exercise actively participate in the critique.

(b) Partial emergency exercises

(1) The purpose of a partial exercise is to ensure the adequacy of the response to individual participating agencies and components of the plan.

~~(1)~~(2) Partial emergency exercises ~~could~~should involve, at least, one unit, such as rescue and ~~fire-fighting~~firefighting services, or medical, or combination of several units, as appropriate.

~~(2)~~(3) Partial emergency exercises should ensure that any deficiencies found during the full-scale airport emergency exercise have been corrected.

(c) Tabletop exercises

Tabletop exercises ~~may~~should be held ~~every six months, except during~~at regular intervals. The aim of these exercises should be to verify that six-month period when roles and procedures are clear and understood. These exercises offer a good opportunity to test new or revised procedures, before implementation, or preparation for a full-scale emergency exercise is held.

GM12 ADR.OPS.B.005 Aerodrome emergency planning**DISABLED AIRCRAFT REMOVAL**

(a) The aerodrome operator should establish a plan for the removal of an aircraft disabled on, or adjacent to, the movement area, and a coordinator designated to implement the plan, when necessary.

(b) The disabled aircraft removal plan should be based on the characteristics of the aircraft that may normally be expected to operate at the aerodrome, and include among other things:

(1) a list of equipment and personnel on, or in the vicinity of, the aerodrome which would be available for such purpose; and

(2) arrangements for the rapid receipt of aircraft recovery equipment kits available from other aerodromes;

AMC1- ADR- OPS.B.010 — ~~Communication and alerting systems~~ ^{FFF} Rescue and fire fighting services

SUBPART B – AERODROME OPERATIONAL SERVICES, EQUIPMENT AND INSTALLATIONS (ADR.OPS.B)

COMMUNICATION AND ALERTING SYSTEMS

The aerodrome operator should ensure that:

- (a) a discrete communication system is provided linking a fire station with the control tower, any other fire station on the aerodrome, and the rescue and ~~fire-fighting~~ firefighting vehicles;
- (b) an alerting system for rescue and ~~fire-fighting~~ firefighting personnel, capable of being operated from that station, is provided at the fire station, any other fire station on the aerodrome, and the aerodrome control tower;
- (c) communication means are provided for direct communication between the rescue and firefighting service and the flight crew of an aircraft in emergency;
- (d) communication means are provided to ensure the immediate summoning of designated personnel not on standby duty;
- (e) communication means are provided to ensure two-way communication with the rescue and firefighting vehicles in attendance at an aircraft accident or incident.
- (f) communications during emergencies should be recorded;
- (g) communication means are provided between rescue and firefighting crew members; and
- (h) a system for monitoring the movement area for incidents is provided.

AMC2-ADR-OPS.B.010 — Rescue and fire-fighting services

RFFS ~~level of protection~~ ^{RFF} LEVEL OF PROTECTION

- (a) The aerodrome operator should ensure that:
 - (1) the level of protection normally available at an aerodrome is determined and expressed in terms of the category of the rescue and ~~fire-fighting~~ firefighting services (RFF aerodrome category) as described in (2), (3), and (4) below and in accordance with the types, amounts, and discharge rates of extinguishing agents normally available at the aerodrome; and
 - (2) the RFF aerodrome category is determined according to the Table 1, based on the longest aeroplanes ~~expected to operate at~~ normally using the aerodrome and their fuselage width. If, after selecting the category appropriate to the longest aeroplane's overall length, that aeroplane's fuselage width is greater than the maximum width in Table 1, column 3, for that category, then the category for that aeroplane should actually be one category higher.

SUBPART B – AERODROME OPERATIONAL SERVICES, EQUIPMENT AND INSTALLATIONS (ADR.OPS.B)

Aerodrome category for rescue and fire fighting		
Aerodrome Category (1)	Aeroplane overall length (2)	Maximum fuselage width (3)
1	0_m up to but not including 9_m	2_m
2	9_m up to but not including 12_m	2_m
3	12_m up to but not including 18_m	3_m
4	18_m up to but not including 24_m	4_m
5	24 m up to but not including 28_m	4_m
6	28_m up to but not including 39_m	5_m
7	39_m up to but not including 49_m	5 m
8	49_m up to but not including 61_m	7_m
9	61_m up to but not including 76_m	7_m
10	76_m up to but not including 90_m	8_m

Table 1

~~(3) If the number of expected movements of the aeroplanes in the RFF category is less than 700 in the busiest consecutive three months, the level of protection is not less than one category below the determined category;~~

~~(4) If the number of expected movements of the aeroplanes in the RFF category is equal or above 700 in the busiest consecutive three months, the level of protection is equal to the determined category;~~

- (b) The aerodrome operator should ensure that during anticipated periods of reduced activity, the level of protection available is no less than that needed for the highest category of aeroplane planned to use the aerodrome during that time, irrespective of the number of movements.

SUBPART B – AERODROME OPERATIONAL SERVICES, EQUIPMENT AND INSTALLATIONS (ADR.OPS.B)

AMC3-ADR-OPS.B.010 — ~~Number of~~ Rescue and fire fighting services

NUMBER OF RFFS ~~vehicles and rescue equipment~~^{TXF} VEHICLES AND RESCUE EQUIPMENT

- (a) The aerodrome operator should ensure that:
- (1) the minimum number of rescue and ~~fire-fighting~~ firefighting vehicles at the aerodrome~~7~~ will be in accordance with the following table~~;~~ and

Aerodrome category	Rescue and fire- <u>fighting</u> firefighting vehicles
1	1
2	1
3	1
4	1
5	1
6	2
7	2
8	3
9	3
10	3

Table 1

- (2) ~~Rescue~~ rescue equipment commensurate with the level of aircraft operations is provided on the rescue and ~~fire-fighting~~ firefighting vehicles~~;~~ ;
- (b) If the aerodrome is located near a water/swampy area~~,~~ or other difficult environment, or a significant portion of the approach/departure operations ~~tak~~ takes over these areas, the aerodrome operator should ~~ensure that~~ coordinate the availability of suitable rescue equipment and services~~are available.~~

AMC4-ADR-OPS.B.010 — ~~Extinguishing agents~~^{TXF} Rescue and fire fighting services

EXTINGUISHING AGENTS

The aerodrome operator should ensure that:

- (a) ~~Both~~ both principal and complementary extinguishing agents are provided at the aerodrome;
- (b) ~~Principal~~ principal extinguishing agent includes:

AMC/GM to Annex III – Part-OPS

SUBPART B – AERODROME OPERATIONAL SERVICES, EQUIPMENT AND INSTALLATIONS (ADR.OPS.B)

- (1) a foam meeting the minimum performance level A; or
- (2) a foam meeting the minimum performance level B; or
- ~~(3) a foam meeting the minimum performance level C; or~~
- ~~(4)~~(3) a combination of these agents;

except for aerodromes in categories 1 to 3, where it should preferably meet the minimum performance level B;

- (c) ~~The~~the complementary extinguishing agent is a dry chemical powder suitable for extinguishing hydrocarbon fires, or any other alternate agent having equivalent ~~fire-fighting~~firefighting capability;
- (d) ~~The~~the amounts of water for foam production, and of the complementary agents provided on the rescue and ~~fire-fighting~~firefighting vehicles are in accordance with the determined aerodrome category and Table 1~~7~~.

Minimum usable amounts of extinguishing agents								
Aerodrome category (1)	Foam meeting performance level A		Foam meeting performance level B		Foam meeting performance level C		Complementary agents	
	Water (L) (2)	Discharge rate foam solution/minute (L) (3)	Water (L) (4)	Discharge rate foam solution/minute (L) (5)	Water (L) (6)	Discharge rate foam solution/minute (L) (7)	Dry chemical powders (kg) (8)	Discharge Rate (kg/sec) (9)
1	350	350	230	230	160	160	45	2.25
2	1 000	800	670	550	460	360	90	2.25
3	1 800	1 300	1 200	900	820	630	135	2.25
4	3 600	2 600	2 400	1800	1 700	1 100	135	2.25
5	8 100	4 500	5 400	3 000	3 900	2 200	180	2.25
6	11 800	6 000	7 900	4 000	5 800	2 900	225	2.25
7	18 200	7 900	12 100	5 300	8 800	3 800	225	2.25
8	27 300	10 800	18 200	7 200	12 800	5 100	450	4.5
9	36 400	13 500	24 300	9 000	17 100	6 300	450	4.5
10	48 200	16 600	32 300	11 200	22 800	7 900	450	4.5

Note: The quantities of water shown in columns 2, 4 and 6 are based on the average overall length of aeroplanes in a given category

~~Table 1~~

Table 1

SUBPART B – AERODROME OPERATIONAL SERVICES, EQUIPMENT AND INSTALLATIONS (ADR.OPS.B)

except that for aerodrome categories 1 and 2, up to 100-% of the water may be replaced by complementary agent, or for aerodrome categories 3 to 10 when a foam meeting performance level A is used, up to 30 % of the water may be replaced by complementary agent.

For the purpose of agent substitution, 1-kg of complementary agent is equivalent if to 1-L of water for ~~foam~~-production of a foam meeting performance level A and 0.66 L of water for production of a foam meeting performance level B.

Note 1: The amounts of water specified for foam production are predicated on an application rate of 8.2-L/min/m² for a foam meeting performance level A, or 5.5-L/min/m² for a foam meeting performance level B ~~and 3.75L/min/m² for a foam meeting performance level C.~~

~~The quantity~~Note 2: When any other complementary agent id used, the substitution ratios need to be checked.

- (e) the amount of foam ~~concentrates separately~~concentrate provided on ~~vehicles for a~~ vehicle should be sufficient to produce, at least, two loads of foam production is proportionate to the quantity of water provided and the foam concentration selectedsolution;
- (f) ~~When~~when different performance level foams are provided at an aerodrome, the conversion ratio should be calculated, documented for each rescue and ~~fire-fighting~~firefighting vehicle and applied to the overall rescue and ~~fire-fighting~~firefighting requirement;
- (g) ~~The~~the discharge rate of the foam solution is not less than the rates shown in Table ~~13~~;
- (h) ~~The~~the complementary agents comply with the appropriate specifications of the International Organisation for Standardisation (ISO);
- (i) ~~The~~the discharge rate of complementary agents is not less than the values shown in Table ~~17~~;
- (j) a reserve supply of foam concentrate and complementary agent, equivalent to 200 % of the quantities of these agents to be provided in the rescue and fire fighting vehicles, is maintained on the aerodrome for vehicle replenishment purposes. Where a major delay in the replenishment of this supply is anticipated, the amount of reserve supply should be increased;
- (k) a water need analysis is conducted to determine the availability of sufficient quantities of water for fire fighting;
- (l) quantities of water are recalculated and the amount of water for foam production and the discharge rates for foam solution are increased accordingly, where operations by aeroplanes larger than the average size in a given category are planned; and
- (m) arrangements are in place to manage extinguishing agents in terms of selection, storage, maintenance, and testing.

AMC5-ADR-OPS.B.010 — ~~Response time~~^{TXF-REV} Rescue and fire fighting servicesRESPONSE TIME

The aerodrome operator should ensure that:

- (a) ~~Rescue~~ and ~~fire-fighting~~ service ~~achieve~~ achieves a response time not exceeding three minutes with an operational objective of not exceeding two minutes, but in no case exceeding three minutes, to any point of each operational runway, in optimum visibility and surface conditions, and be in a position to apply foam at a rate of, at least, 50 % of the discharge rate specified in AMC4 ADR.OPS.B.010 Table 3;
- (b) ~~Rescue and fire-fighting service achieve a response time not exceeding three minutes~~ response times to any other part of the movement area, in optimum visibility and surface conditions, are calculated and included in the Aerodrome Emergency Plan;
- (c) ~~Any~~ vehicle, other than the first responding vehicle(s), required to ~~deliver~~ achieve continuous agent application of the amount of extinguishing agents specified in Table 1 of ~~AMC4-ADR-OPS.B.010 achieve continuous agent application and arrive in three minutes, but in no case exceeding four minutes, from the initial call;~~ ADR.OPS.B.010 arrives one minute after the first responding vehicle(s); and
- (d) ~~Suitable~~ guidance, equipment and/or procedures for rescue and ~~fire-fighting~~ services are provided, to meet the operational objective, as nearly as possible, in less than optimum conditions of visibility, especially during low visibility operations.

AMC6-~~ADR-~~OPS.B.010 — ~~Personnel~~^{FXT-REV} Rescue and fire fighting servicesPERSONNEL

The aerodrome operator should ensure that:

- (a) ~~During~~during flight operations and, at least, 15 minutes after the departure of last flight, sufficient trained personnel is detailed and readily available to ride the rescue and ~~fire-~~fighting~~firefighting~~ vehicles, and to operate the equipment at maximum capacity;
- (b) ~~Personnel~~personnel is deployed in a way that ensures the minimum response times can be achieved, and continuous agent application at the appropriate rate can be fully maintained considering also the use of hand lines, ladders, and other rescue and ~~fire-~~fighting~~firefighting~~ equipment normally associated with aircraft rescue and ~~fire-~~fighting~~firefighting~~ operations;
- (c) ~~All~~all responding rescue and ~~fire-~~fighting~~firefighting~~ personnel are provided with protective clothing and respiratory equipment to enable them to perform their duties in an effective manner; and
- (d) any other duties carried out by rescue and firefighting personnel do not compromise the response, or their safety.

AMC7-~~ADR-~~OPS.B.010 — ~~Training of~~ Rescue and fire fighting servicesTRAINING OF RFFS ~~personnel~~^{FXT-REV} PERSONNEL

The aerodrome operator should ensure that:

- (a) ~~The~~the rescue and ~~fire-~~fighting~~firefighting~~ personnel are properly trained to perform their duties in an efficient manner, and actively participate in live fire drills commensurate with the types of aircraft, and type of rescue and ~~fire-~~fighting~~firefighting~~ equipment in use at the aerodrome, including pressure-fed fuel fires drills; and
- (b) ~~The~~the rescue and ~~fire-~~fighting~~firefighting~~ personnel training programme includes training in human performance, including team coordination.

AMC8-~~ADR-~~OPS.B.010 — ~~Medical standards for RFFS personnel~~^{ADD-REV} Rescue and fire fighting servicesMEDICAL STANDARDS FOR RFFS PERSONNEL

The aerodrome operator should ~~determine/ensure~~ an~~that~~ appropriate medical ~~standard to~~ bestandards are met by ~~RFF~~RFFS personnel.

GM1-~~ADR-~~OPS.B.010 — ~~Availability of rescue~~ Rescue and fire- fighting servicesAVAILABILITY AND SCOPE OF RESCUE AND FIRE FIGHTING SERVICES

Public or private organisations, suitably located and equipped, ~~may~~could be designated to provide the rescue and ~~fire-~~fighting~~firefighting~~ service. The fire station housing these

SUBPART B – AERODROME OPERATIONAL SERVICES, EQUIPMENT AND INSTALLATIONS (ADR.OPS.B)

organisations ~~may~~should normally be located on the aerodrome, although an off-aerodrome location is not precluded, provided that the response time can be met. The scope of the rescue and fire fighting services is to save lives in the event of an aircraft accident or incident occurring at, or in the immediate surroundings of, the aerodrome. The operational objective is to create and maintain survivable conditions, to provide egress routes for occupants, and to initiate the rescue of those occupants unable to make their escape without direct aid.

GM2-~~ADR-~~OPS.B.010 —~~Communication System~~ Rescue and fire fighting services

- ~~(a) Communication means are provided for direct communication between the rescue and fire fighting service and the flight crew of an aircraft in emergency;~~
- ~~(b) Communication means are provided to ensure the immediate summoning of designated personnel not on standby duty;~~
- ~~(c) Communication means are provided to ensure two way communication with the rescue and fire fighting vehicles in attendance at an aircraft accident or incident.~~

GM3-~~ADR~~OPS.B.010 —~~Number of~~NUMBER OF RFFS ~~personnel~~PERSONNEL

In determining the number of personnel required to provide for rescue, and fire fighting, a Task and Resource Analysis should be performed, taking into consideration is necessary to be given to the types of aircraft usingoperating at the aerodrome. Staffing levels are promulgated, or reference to, the Aerodrome Manual, the available rescue and fire fighting vehicles and equipment, any other duties required from RFFS personnel, etc.

GM4-~~GM3~~ ADR-OPS.B.010 —~~Training of~~ Rescue and Fire Fighting Personnel~~fire fighting services~~TRAINING OF RESCUE AND FIRE FIGHTING PERSONNEL

The training of rescue and ~~fire fighting~~firefighting personnel may include initial and recurrent training in, at least, the following areas:

- (a) airport familiarisation;
- (b) aircraft familiarisation;
- (c) rescue and ~~fire fighting~~firefighting personnel safety;
- (d) emergency communications systems on the aerodrome, including aircraft fire-related alarms;
- (e) use of the fire hoses, nozzles, turrets, and other appliances;
- (f) application of the types of extinguishing agents required;
- (g) emergency aircraft evacuation assistance;
- (h) ~~fire fighting~~firefighting operations;

SUBPART B – AERODROME OPERATIONAL SERVICES, EQUIPMENT AND
INSTALLATIONS (ADR.OPS.B)

- (i) adaptation and use of structural rescue and ~~fire-fighting~~firefighting equipment for aircraft rescue and ~~fire-fighting~~firefighting;
- (j) dangerous goods;
- (k) familiarisation with fire fighters' duties under the aerodrome emergency plan; ~~and~~
~~(1) —protective clothing and respiratory protection;~~
- (l) low visibility procedures;
- (m) human performance, including team coordination;
- (n) protective clothing and respiratory protection;
- (o) composite materials; and
- (p) recognition of aircraft ballistic parachute systems during emergency operations.

GM4 ADR.OPS.B.010 Rescue and firefighting services

NUMBER OF RFFS VEHICLES AND RESCUE EQUIPMENT

Special fire fighting equipment may not be provided for water areas; this does not prevent the provision of such equipment if it would be of practical use, such as when the areas concerned include reefs or islands. The objective should be to plan and deploy the necessary life-saving flotation equipment, as expeditiously as possible, in a number commensurate with the largest aeroplane normally using the aerodrome.

GM5 ADR.OPS.B.010 Rescue and fire fighting services

REDUCTION OF RFFS AERODROME CATEGORY

- (a) The level of protection could be one category below the determined category if the number of movements of the aeroplanes in the highest RFF aerodrome category normally using the aerodrome is less than 700 in the busiest consecutive three months.
- (b) The level of protection should be equal to the determined category if the number of movements of the aeroplanes in the highest RFF aerodrome category normally using the aerodrome is equal or above 700 in the busiest consecutive three months.
- (c) For aerodromes serving exclusively all-cargo aircraft operations, the RFF aerodrome category could be adjusted to a category lower than the one for passenger aircraft operations, provided that the principal objective, to save lives in the event of an aircraft accident or incident, is met and such reduction is approved by the Competent Authority.
- (d) Unforeseen circumstances leading to temporary reduction of the level of protection of the aerodrome rescue and fire fighting services are considered any unplanned events that lead to unavailability of facilities, equipment, and resources, such as:
 - (2) breakdown of RFFS vehicles;
 - (3) staff shortage;
 - (4) unavailability of extinguishing agents;
 - (5) RFFS response to an accident;
 - (2)(6) Etc.

AMC1

AMC-ADR.OPS.B.015 — Monitoring and Inspection of movement area and related facilities ^{APP}

GENERAL

- (a) — The aerodrome operator should establish a monitoring and inspection program of the movement area which is commensurate with the traffic expected at the aerodrome. Inspections of the movement area should be carried out each day at least once where the code number is 1 or 2 and at least twice where the code number is 3 or 4;

SUBPART B – AERODROME OPERATIONAL SERVICES, EQUIPMENT AND INSTALLATIONS (ADR.OPS.B)

The inspections should cover at least the following items:

- ~~(1) Visual aids;~~
- ~~(2) Other lighting systems required for the safety of aerodrome operations;~~
- ~~(3) Pavements and adjacent ground surfaces;~~
- ~~(4) Drainage systems;~~
- ~~(5) Fencing and other access control devices;~~
- ~~(6) The movement area environment inside the aerodrome boundary, and outside the aerodrome boundary within line of sight;~~
- ~~(7) FOD and wildlife;~~

~~(b)~~(a) in order to identify any default or potential hazards to the safety of aircraft or aerodrome operations.

~~(b) Inspections of the movement area covering items such as the presence of FOD, the status of visual aids, wildlife and current surface conditions, should be carried out each day, at least, once where the code number is 1 or 2, and, at least, twice where the code number is 3 or 4.~~

~~(c) Inspections covering other items such as other lighting systems required for the safety of aerodrome operations, pavements and adjacent ground surfaces, drainage and storm water collection systems, fencing and other access control devices, the movement area environment inside the aerodrome boundary and outside the aerodrome boundary within line of sight, should be carried out, at least, weekly.~~

~~(d) The aerodrome operator, during excessive weather events (excessive heat, freeze and thaw periods, following a significant storm, etc.) should be conducting extra inspections of paved areas to check for pavement blow-ups and debris that could damage aircraft, or cause pilots to lose directional control.~~

~~(e) The aerodrome operator should keep a log for all routine and non-routine inspections of the movement area and related facilities.~~

AMC2

GM1 ADR OPS.B.015 — Pavements and adjacent ground surfaces inspection

ADR.OPS.B.015 Monitoring and inspection of movement area and related facilities

PERSONNEL REQUIREMENTS FOR MOVEMENT AREA INSPECTIONS

~~(a) The aerodrome operator should designate the personnel responsible for carrying out movement area inspections.~~

~~(b) The aerodrome operator should ensure that personnel conducting movement area inspections receive training in, at least, the following areas:~~

~~(1) aerodrome familiarisation, including aerodrome markings, signs, and lighting;~~

~~(1)(2) Aerodrome Manual;~~

- ~~(2)~~(3) Aerodrome Emergency Plan;
- ~~(3)~~(4) Notice to Airmen (NOTAM) notification procedures;
- (5) aerodrome driving rules;
- (6) procedures of radiotelephony;
- (7) aerodrome inspection procedures and techniques; and
- (8) procedures for reporting inspection results and observations;

GM1 ADR.OPS.B.015 Monitoring and inspection of movement area and related facilities

PAVEMENTS AND ADJACENT GROUND SURFACES INSPECTION

- (a) Paved Areas Inspection
- ~~(b) Paved Areas Inspection~~

The following ~~may~~should be observed during ~~an inspection of~~ paved areas ~~inspection~~:

- (1) ~~general~~General cleanliness with particular attention to material which could cause engine ingestion damage. This may include debris from runway maintenance operations, or excessive grit remaining after runway gritting. ~~Any build-up of tire rubber deposits should be noted;~~
- (2) Signs~~presence of contaminants such as snow, slush, ice, wet ice, wet snow on ice or frost, water, anti-icing or de-icing chemicals, mud, dust, sand, volcanic ash, oil, rubber deposits which may impair the runway surface friction characteristics; particular attention should be given to the simultaneous presence of snow, slush, ice, wet ice, wet snow on ice with anti-icing or de-icing chemicals;~~
- ~~(2)~~(3) signs of damage to the pavement surface including cracking and ~~spallings~~spall of concrete, condition of joint sealing, cracking and looseness of aggregate in asphalt surfaces, or break-up of friction courses;
- ~~(3)~~(4) After~~after~~ rain, flooded areas should be identified and marked, if possible, to facilitate later resurfacing;
- ~~(4)~~(5) damage of light fittings;
- ~~(5)~~(6) cleanliness of runway markings;
- ~~(6)~~(7) the condition and fit of pit covers; and
- ~~(7)~~(8) The~~the~~ extremities of the runway should be inspected for early touchdown marks; blast damage to approach lights, marker cones and threshold lights; cleanliness and obstacles in the runway end safety area.

- (c) Adjacent ground surfaces inspection

The following may be observed during the inspection:

- (1) the general state of ground cover vegetation ensuring, in particular, that excessive length is not obscuring lights, signs, markers, etc.;

SUBPART B – AERODROME OPERATIONAL SERVICES, EQUIPMENT AND INSTALLATIONS (ADR.OPS.B)

- (2) any developing depressions should be noted and plotted;
- (3) any unreported aircraft wheel tracks should be carefully plotted and reported;
- (4) the condition of signs and markers;
- (5) the general bearing strength of grass areas, particularly those close to aircraft pavement surface;
- (6) waterlogged grass areas; and
- (7) FOD and wildlife.

GM2- ADR-OPS.B.015 — Visual Aids Inspection — Monitoring and inspection of movement area and related facilities

VISUAL AIDS INSPECTION

- (a) Flight checks of visual aids

Flight checks of approach and runway lighting systems ~~are periodically~~should be carried out to ensure the pattern is correct and the lights are working-, whenever a new system is commissioned, or after a major maintenance, and at least annually. The opportunity should also be taken to identify any confusing, or misleading lights in the vicinity of the aerodrome.

- (b) Ground checks of visual aids

~~Ground checks of light units in approach lighting systems and runway lighting systems may be performed regularly. The checks ensure that the requirements for intensity, beam coverage and beam direction are fulfilled.~~

Photometric testing of runway lighting and approach lighting that is accessible with the equipment to be used, should be carried out in a targeted manner aimed at maintaining high levels of serviceability. The regularity of testing should be adjusted to achieve the target level of serviceability applicable to the service being tested.

GM3- ADR-OPS.B.015 — Obstacles — Monitoring and inspection of movement area and related facilities

OBSTACLES

- (a) All authorised obstacles ~~are~~should be checked for proper lighting and marking;.
- (b) Any unauthorised obstacles ~~are~~should be reported to the designated persons or organisations immediately.

GM4- ADR-OPS.B.015 — Inspection logbook — Monitoring and inspection of movement area and related facilities

SUBPART B – AERODROME OPERATIONAL SERVICES, EQUIPMENT AND INSTALLATIONS (ADR.OPS.B)

~~(a) It is necessary to keep a logbook for all the routine and non-routine inspections of the movement area and related facilities;~~

INSPECTION LOG

The inspection ~~logbook~~log should include:

- (a) ~~Details~~details of inspection intervals and times;
- (b) ~~Names~~names of persons carrying out the inspection; and
- (c) ~~Findings, results and observations~~ if any.

GM5-~~_ADR-OPS.B.015~~ — ~~Follow up of inspections~~ Monitoring and inspection of movement area and related facilities

FOLLOW-UP OF INSPECTIONS

Arrangements ~~may~~should exist for reporting the results of inspections, and for taking prompt follow-up actions to ensure correction of unsafe conditions. These arrangements could include, depending on the result or observation, notification to air traffic services and aeronautical information services, removal of FODs, wildlife control, recording of events for further analysis according to the aerodrome operator's SMS requirements, etc.

GM6-~~_ADR-OPS.B.015~~ — ~~Personnel requirements for~~ Monitoring and inspection of movement area inspections and related facilities

~~(a) The names and roles of persons responsible for carrying out inspections may be designated.~~

~~(b) Personnel who conduct inspections may receive training in at least the following areas:~~

~~(1) Aerodrome familiarisation, including airport signs, markings and lighting;~~

~~(4)(9) Aerodrome Manual;~~

~~(5)(10) Aerodrome Emergency Plan;~~

~~(6)(11) Notice to Airmen (NOTAM) notification procedures;~~

~~(2) Aerodrome driving rules;~~

~~(3) Aerodrome inspection procedures and techniques;~~

~~(4) Procedures for reporting inspection findings.~~

~~(c)(a) Inspectors — mayPERSONNEL REQUIREMENTS FOR MOVEMENT AREA INSPECTIONS~~ Inspectors should use checklists covering the various inspection areas. A sketch of the aerodrome should accompany the checklist so that the location of problems can be marked for easy identification.

~~(d)(b) Inspectors mayshould review the most recently completed checklist from the previous inspection cycle prior to beginning the inspection.~~

SUBPART B – AERODROME OPERATIONAL SERVICES, EQUIPMENT AND
INSTALLATIONS (ADR.OPS.B)

~~(e)~~(c) If construction ~~is or works are~~ in progress, inspectors should be familiar with the safety plan of the construction ~~or works~~.

~~AMC-AMC1 ADR-OPS.B.020 – Wildlife Strike Hazard Reduction~~^{ADD} strike hazard reduction

GENERAL

The aerodrome operator should:

- (a) participate in the national wildlife strike hazard reduction programme;
- (b) establish procedures to record and report to the ~~competent~~appropriate authority wildlife strikes to aircraft occurred at the aerodrome, in close cooperation with organisations operating, or providing services at the aerodrome;
- (c) ensure that wildlife hazard assessments are made by competent personnel; and
- (d) establish, implement and maintain a wildlife risk management programme.

~~GM1-ADR-OPS.B.020 – Wildlife Risk Assessment~~ strike hazard reduction

WILDLIFE RISK ASSESSMENT

- (a) The aerodrome operator ~~may~~should:
 - (1) conduct a risk assessment using strike data for each species, as well as information on the presence of species, the number of individuals, and their biology, and update this regularly;
 - (2) take into account the number of strikes for each species and the severity of damage arising from those strikes; and
 - (3) target actions on those species which ~~occur~~are present with the highest frequency and create the greatest damage.
- (b) Wildlife risk assessments ~~may~~should be made by ~~competent~~qualified personnel.

~~GM2-ADR-OPS.B.020 – Wildlife Risk Management Program~~ strike hazard reduction

WILDLIFE RISK MANAGEMENT PROGRAM

The wildlife risk management program may cover an area of approximately 13 km (7 NM) from the aerodrome reference point, and should include, at least, the following elements:

- (a) assignment of personnel:
 - (1) a person who is accountable for developing and implementing the wildlife risk programme;
 - (2) a person who oversees the daily wildlife control activities, and analyses the collected data and ~~carry~~carries out risk assessments in order to develop and implement the wildlife risk management programme; and

SUBPART B – AERODROME OPERATIONAL SERVICES, EQUIPMENT AND INSTALLATIONS (ADR.OPS.B)

- (3) trained and qualified staff who detect and record the birds/wildlife_x and assess the bird/wildlife hazard_x and ~~to expel hazardous birds/wildlife_x~~
- (b) a process to report, collect_x and record data of struck and living birds/wildlife;
- (c) a process to analyse the data and to assess the bird/wildlife hazard to develop mitigation, proactive_x and reactive measures. This should include a risk assessment methodology;
- (d) a process of habitat and land management both on_x and in its vicinity surroundings, whenever possible, in order to reduce the attractiveness of the area to birds/wildlife;
- (e) a process to ~~expel or~~ remove hazardous birds/wildlife, ~~including by lethal means where appropriate~~;
- (f) a process for liaison with non-airport agencies and local landowners_x etc. to ensure the airport is aware of developments that may contribute to creating additional bird hazards within the airport vicinity's infrastructure, vegetation, land use and activities (for example crop harvesting, seed planting, ploughing, establishment of land or water features, hunting, etc. that might attract birds/wildlife).

GM3-ADR-OPS.B.020 – Wildlife ~~training-strike hazard reduction~~

TRAINING FOR WILDLIFE CONTROL

- (a) The aerodrome wildlife control personnel ~~is necessary to~~should receive formal training prior to their initial engagement as wildlife controllers_x;
- (b) Training for aerodrome wildlife control ~~may~~should be documented and records of it should be retained_x to satisfy periodic reviews, audits_x and competence checks;
- ~~(e)~~ Training of airport wildlife control personnel ~~is~~should be conducted by qualified aerodrome wildlife control personnel_x or specialists with proven experience in this field_x;
- ~~(d)~~(c) ~~Successful completion of an airport wildlife training course is demonstrated by completion of a written and/or practical test to an agreed pass score_x~~;
- ~~(e)~~(d) Wildlife control initial training ~~may~~should, at least_x address the following general areas:
 - (1) ~~understand an~~ understanding of the nature and extent of the aviation wildlife management problem_x and local hazard identification;
 - (2) an understanding of the national and local regulations, standards_x and guidance material related to airport wildlife management programs (use of best-practice models);
 - (3) appreciation of the local wildlife ecology and biology, including (where applicable) the importance of good airfield grass management policies_x and the benefits they can deliver to wildlife control ~~they can deliver~~;
 - (4) the importance of accurate wildlife identification and observations, including the use of field guides;

SUBPART B – AERODROME OPERATIONAL SERVICES, EQUIPMENT AND INSTALLATIONS (ADR.OPS.B)

- (5) local and national laws and regulations relating to rare and endangered species, and species of special concern, and the aerodrome operators policies relating to them;
- (6) wildlife strike remains collection, and identification policies and procedures;
- (7) long-term (passive) control measures, including on and off airport habitat management, including identification of wildlife attractions, vegetation policies, air navigation aids protection, and drainage system, and water body management practicalities;
- (8) short-term (active) tactical measures, using well established effective wildlife removal, dispersal, and control techniques;
- (9) documentation of wildlife activities and control measures, and reporting procedures (the aerodrome wildlife management plan);
- (10) firearms and field safety, including the use of personal protective equipment; and
- (11) wildlife strike risk assessment and risk management principles, and how these programs integrate with the aerodrome's safety management system.

(f)(e) Wildlife control staff ~~is necessary to~~ should be fully aware of the conditions and terms of the operations of the aerodrome environment. Where this is not relevant, the wildlife control personnel should receive appropriate training, including:

- (1) ~~Aerodrome~~ aerodrome airside driver training, including aerodrome familiarisation, air traffic control communications, signs and marking, navigational aids, aerodrome operations, and safety and other matters the aerodrome operator ~~deem~~ deems appropriate; and
- (2) ~~Aircraft~~ aircraft familiarisation, including aircraft identification, aircraft engine design, and impact of wildlife strikes on aircraft systems.

(g)(f) It ~~has to~~ should be ensured that wildlife control staff maintains competence in the role. This could be achieved either by ~~annual~~ regular refresher training or another system of monitoring, acceptable to the ~~competent~~ appropriate authority. The maintenance of competence ~~may~~ should include the areas in (ed) and (fe) above, and also include:

- (1) reviewing firearms safety;
- (2) changes in the local environment;
- (3) changes in risk management policy;
- (4) recent wildlife events at the aerodrome;
- (5) improvements in active and passive measures; and
- (6) any other matters ~~as~~ the airport operator deems appropriate.

GM4-ADR-OPS.B.020 — ~~Recording and reporting of wildlife strikes and observed wildlife~~ Wildlife strike hazard reduction

RECORDING AND REPORTING OF WILDLIFE STRIKES AND OBSERVED WILDLIFE

- (a) It is necessary to maintain a record of all wildlife activity or 'bird/wildlife log'. The log ~~may~~should include, at least, the following information:
- (1) ~~Numbers~~numbers, species, and location of birds/wildlife seen; and
 - (2) ~~Actions~~actions taken ~~to~~to disperse birds/wildlife, and the results of these actions;
- (b) The log ~~is~~should be completed at regular intervals by the wildlife control staff;
- (c) The log ~~is~~should be analysed to identify which species represent a hazard, at which times of day or year, or under which weather conditions, etc.;
- (d) The aerodrome operator ~~may~~should have a system in place to collect bird/wildlife strike reports in close cooperation with data owners, like aircraft operators, air navigation service providers, aircraft engine maintenance departments, etc.

AMC-AMC1 OPS.B.025 — ~~Operation of vehicles~~ ^{ADD}

TRAINING PROGRAMME

- (a) Depending upon the scale and complexity of the aerodrome and the individual requirements of the driver, the training programme should take into account the following main areas:
- (1) a generic airside vehicle driver training programme which covers operational safety ~~and the health and safety aspects~~ of operating vehicles, ~~plant~~ and equipment in close proximity to aircraft on the movement ~~and manoeuvring areas, such as runways, taxiways,~~ aprons, stands ~~and~~, airside roads, and areas adjacent to the movement area;
 - (2) specific training on the vehicle, ~~plant and or~~ equipment, e.g. car, tug, high loader, coach;
 - (3) ~~Drivers required to operate on the manoeuvring area should receive~~ additional training on the hazards associated with runways and taxiways, and in the correct use of RTF and standard phraseology; should be received by drivers required to operate on the manoeuvring area.
- (b) An aerodrome operator should establish a system for issuing movement area driving authorisations, and the conditions of their renewal.

GM1-AMC2 ADR-OPS.B.025 — ~~Movement Area Driving Training~~ Operation of vehicles

MOVEMENT AREA DRIVING TRAINING

The training for driving on the movement area ~~may~~should include the following:

SUBPART B – AERODROME OPERATIONAL SERVICES, EQUIPMENT AND
INSTALLATIONS (ADR.OPS.B)

- (a) the geography of the aerodrome;
- (b) aerodrome signs, markings and lights; and
- (c) radiotelephone operating procedures, if the duties require to drive on the manoeuvring area;
- (d) terms and phrases used in aerodrome control, including the ICAO spelling alphabet, if the duties require interaction with aerodrome control;
- (e) rules of air traffic services as they relate to ground operations;
- (f) airport rules and procedures;
- (g) low visibility procedures; and
- (h) specialist functions as required, for example, in rescue and ~~fire-fighting~~firefighting.

GM2-GM1 ADR-OPS.B.025 — ~~Grant, suspension or revocation~~ Operation of an airside driving permit vehicles

GRANT, SUSPENSION OR REVOCATION OF AN AIRSIDE DRIVING AUTHORISATION

- (a) The aerodrome operator ~~may~~should grant an airside driving ~~permit~~authorisation to persons provided that:
 - (1) ~~Their~~their tasks involve driving on the movement area;
 - (2) ~~They~~they hold a State driving license or any other driving license recognised by the State;
 - (3) ~~They~~they hold a special State driving license if their duties involve the operation of a specialised vehicle;
 - (4) ~~Meet~~they meet the medical criteria according to the National Legislation;
 - (5) ~~Hold~~they hold a State Radiotelephony Operating License, or have a specific training on radiotelephony if ~~it~~their duties involve driving on the manoeuvring area;
 - (6) ~~Have~~they have successfully completed an airside driving ~~classroom~~theoretical course, and passed the written exams;
 - (7) ~~Have~~they have successfully demonstrated competency, as appropriate, in:
 - (i) ~~The~~the operation, or use of vehicle transmit/receive equipment;
 - (ii) ~~Understanding~~understanding and complying with air traffic control and local procedures;
 - (iii) ~~Vehicle~~vehicle navigation on the aerodrome; and
 - (iv) ~~Special~~special skills required for the particular function.
- (b) The airside driving ~~permit~~mayauthorisation should be valid for 2-yearsa limited period of time, and renewed thereafter, provided that the driver has successfully completed a refresher training course, and meets the requirements (a)(1)–(a)(4) above;

SUBPART B – AERODROME OPERATIONAL SERVICES, EQUIPMENT AND
INSTALLATIONS (ADR.OPS.B)

- (c) The aerodrome operator ~~may~~could suspend or revoke an airside driving ~~permit~~authorisation when the person:
- (1) ~~Does~~does not fulfil the requirements stated in (a)(1)–(a)(4);
 - (2) ~~Has~~has repeatedly been reported to violate movement area driving rules; and
 - (3) ~~Has~~has been ~~reported~~proved to drive under the effect of alcohol or drugs.
- (d) ~~AMC~~It is not necessary that all operators be trained at the same level. For example, operators whose functions are restricted to the apron. For the same reason, the aerodrome operator could establish different types of driving authorisations, e.g. one class for driving at the apron, and another one for the manoeuvring area which may also have different validity periods.

GM2 ADR.OPS.B.025 Operation of vehicles

DEVELOPMENT OF A FRAMEWORK FOR A VEHICLE DRIVER TRAINING PROGRAMME

AIRSIDE VEHICLE DRIVER

The following elements could be considered when developing programs and knowledge requirements for an airside vehicle driver training programme:

- (a) Airside driving permit (ADP)
- (1) the issuing authority, the validity of the permit in terms of time, conditions of use, and its transferability;
 - (2) ownership of the permit and control, and audit of permit issue;
 - (3) local enforcement, and driving offence procedures; and
 - (4) relationship to State driver licensing system.
- (b) National legislation and regulation
- (1) government/State regulations related to general vehicle driving licenses;
 - (2) State/regional/local government requirements; and
 - (3) national aviation safety authority requirements/guidance for driving airside.
- (c) Aerodrome regulations and requirements
- (1) rules of the air, and ATC procedures applicable to aerodromes as they relate to vehicles, particularly rights of way;
 - (2) specific aerodrome regulations, requirements, and local instructions;
 - (3) local methods used to disseminate general information, and instructions to drivers; and
 - (4) local methods used to disseminate information regarding works in progress.
- (d) Personal responsibilities
- (1) agreed national or airport requirements concerning fitness to drive (medical and health standards);

SUBPART B – AERODROME OPERATIONAL SERVICES, EQUIPMENT AND
INSTALLATIONS (ADR.OPS.B)

- (2) issue and use of personal protective equipment, such as high visibility clothing and hearing protection;
- (3) general driving standards;
- (4) no-smoking/no-drinking requirements airside;
- (5) responsibilities with respect to foreign object debris and fuel/oil spillage; and
- (6) the responsibility to ensure that a vehicle is suitable for the task, and is used correctly.

SUBPART B – AERODROME OPERATIONAL SERVICES, EQUIPMENT AND
INSTALLATIONS (ADR.OPS.B)

(e) Vehicle standards

- (1) condition and maintenance standards agreed at the aerodrome, and/or national level;
- (2) the requirement to display obstruction lights and company insignia;
- (3) the requirement for, and content of, daily vehicle inspections;
- (4) agreed standards of aerodrome and company vehicle fault reporting and rectification; and
- (5) local requirements for the issue and display of airside vehicle permits.

(f) General aerodrome layout

- (1) the general geography of the local aerodrome;
- (2) aviation terminology used such as runway, taxiway, apron, roads, crossings, runway-holding points;
- (3) all aerodrome signs, markings and lighting for vehicles and aircraft;
- (4) specific reference to signs, markings and lighting used to guard runways, and critical areas; and
- (5) specific reference to any controlled/uncontrolled taxiway crossing procedures.

(g) Hazards of general airside driving

- (1) speed limits, prohibited areas, and no parking regulations;
- (2) the danger zones around aircraft;
- (3) engine suction/ingestion and blast, propellers, and helicopters;
- (4) aircraft refuelling;
- (5) foreign object debris and spillages;
- (6) vehicle reversing;
- (7) staff and passengers walking across aprons;
- (8) air bridges and other services such as fixed electrical ground power;
- (9) the general aircraft turnaround process;
- (10) aircraft emergency stop and fuel cut-off procedures;
- (11) hazardous cargo;
- (12) local vehicle towing requirements;
- (13) requirements for driving at night; and
- (14) requirements for driving in adverse weather conditions, particularly low visibility.

(h) Local organisations

- (1) the role of the aerodrome operator in setting and maintaining standards;
- (2) the national aviation safety authority and its responsibilities;
- (3) the national and/or local police, and their involvement with airside driving; and
- (4) other enforcement authorities dealing with vehicles, driving, health, and safety.

SUBPART B – AERODROME OPERATIONAL SERVICES, EQUIPMENT AND
INSTALLATIONS (ADR.OPS.B)

(i) Emergency procedures

- (1) actions and responsibilities in a crisis situation (any accident or significant incident occurring on the airport);
- (2) action in the event of a vehicle accident;
- (3) specific action in the event of a vehicle striking an aircraft;
- (4) action in the event of fire;
- (5) action in the event of an aircraft accident/incident; and
- (6) action in the event of personal injury.

(j) Communications

- (1) radio procedures and phraseologies to be used if applicable;
- (2) light signals used by ATC;
- (3) procedures to be used by vehicle drivers if lost or unsure of position;
- (4) local emergency telephone numbers; and
- (5) how to contact the local aerodrome safety unit.

(k) Practical training (visual familiarisation)

- (1) airside service roads, taxiway crossings, and any restrictions during low visibility;
- (2) aprons and stands;
- (3) surface paint markings for vehicles and aircraft;
- (4) surface paint markings that delineate the boundary between aprons and taxiways;
- (5) signs, markings and lighting used on the taxiway that indicate the runways ahead;
- (6) parking areas and restrictions;
- (7) speed limits and regulations; and
- (8) hazards during aircraft turnarounds and aircraft movements.

MANOEUVRING AREA VEHICLE DRIVER

(a) All drivers expected to operate on the manoeuvring area of the aerodrome should obtain an ADP covering the programme above. Any driver expected to drive on the manoeuvring area should, also, obtain an agreed period of experience in general airside driving before training to operate on the manoeuvring area.

(b) All drivers should be trained initially and be provided with refresher training regularly, with particular additional emphasis on the following areas:

- (1) Aerodrome regulations and requirements
 - (i) air traffic control rules, right of way of aircraft;
 - (ii) the definition of movement areas, manoeuvring areas, aprons, stands; and
 - (iii) methods used to disseminate information regarding works in progress.
- (2) Air traffic control
 - (i) the aerodrome control function and area of responsibility;

SUBPART B – AERODROME OPERATIONAL SERVICES, EQUIPMENT AND
INSTALLATIONS (ADR.OPS.B)

- (ii) the ground movement control function and area of responsibility;
- (iii) normal and emergency procedures used by ATC relating to aircraft;
- (iv) ATC frequencies used and normal handover/transfer points for vehicles;
- (v) ATC call signs, vehicle call signs, phonetic alphabet, and standard phraseology; and
- (vi) demarcation of responsibilities between ATC and apron control if applicable.

(3) Personal responsibilities

- (i) fitness to drive with particular emphasis on eyesight and colour perception;
- (ii) correct use of personal protective equipment;
- (iii) responsibilities with respect to foreign object debris; and
- (iv) responsibilities with respect to escorting other vehicles on the manoeuvring area.

(4) Vehicle standards

- (i) responsibility for ensuring the vehicle used is fit for the purpose and task;
- (ii) requirements for daily inspection prior to operating on the manoeuvring area;
- (iii) particular attention to the display of obstruction and general lights; and
- (iv) serviceability of all essential communications systems with ATC and base operations.

(5) Aerodrome layout

- (i) particular emphasis on signs, markings and lighting used on the manoeuvring area;
- (ii) special emphasis on signs, markings and lighting used to protect the runway;
- (iii) description of equipment essential to air navigation such as instrument landing systems (ILS);
- (iv) description of protected zones related to ILS antenna;
- (v) description of ILS protected areas, and their relation to runway-holding points;
- (vi) description of runway instrument/visual strip, cleared and graded area; and
- (vii) description of lighting used on the manoeuvring area with particular emphasis on those related to low visibility operations.

(6) Hazards of manoeuvring area driving

- (i) engine suction/ingestion and blast, vortex, propellers, and helicopter operations;
- (ii) requirements for driving at night;
- (iii) requirements for operations in low visibility and other adverse weather conditions;
- (iv) procedures in the event of a vehicle or radio becoming unserviceable while on the manoeuvring area; and

SUBPART B – AERODROME OPERATIONAL SERVICES, EQUIPMENT AND
INSTALLATIONS (ADR.OPS.B)

(v) right of way of aircraft, towed aircraft, and rescue and fire fighting vehicles in an emergency.

(7) Emergency procedures

(i) actions to be taken in the event of a vehicle accident/incident;

(ii) actions to be taken in the event of an aircraft accident/incident;

(iii) actions to be taken if foreign object debris or other debris is found on runways and taxiways;

(iv) procedures to be used by vehicle drivers if lost or unsure of their position; and

(v) local emergency telephone numbers.

(8) Aircraft familiarisation

(i) knowledge of aircraft types and ability to identify all types normally operating at the aerodrome;

(ii) knowledge of airline call signs; and

(iii) knowledge of aircraft terminology relating to engines, fuselage, control surfaces, undercarriage, lights, vents, etc.

(9) Practical training (visual familiarisation)

(i) all runways (including access and exit routes), holding areas, taxiways and aprons;

(ii) all signs, surface markings and lighting associated with runways, holding positions, CAT I, II, and III operations;

(iii) all signs, surface markings and lighting associated with taxiways;

(iv) specific markings that demarcate the boundary between aprons and manoeuvring areas;

(v) navigation aids such as ILS, protected area, antenna, RVR equipment, and other meteorological equipment;

(vi) hazards of operating around aircraft landing, taking off or taxiing; and

(vii) any locally used naming convention for particular areas or routes.

RADIOTELEPHONY

All drivers of vehicles operating on the manoeuvring area should be expected to display a high degree of competence with respect to the use of RTF phraseology and ICAO language requirements for air ground radiotelephony communications. Emphasis should be placed on the following areas:

(a) Hierarchy of message priority

Message priorities, an understanding of distress, alerting, control and information messages.

(b) Phonetic alphabet

Correct pronunciation of letters, words, and numbers.

SUBPART B – AERODROME OPERATIONAL SERVICES, EQUIPMENT AND
INSTALLATIONS (ADR.OPS.B)

(c) Standard phraseology

- (1) emphasis on the need for drivers to use standard phraseology; and
- (2) the need for caution with certain phrases such as 'cleared' and 'go ahead'.

(d) Call signs for aircraft, ATC, and vehicles

- (1) an understanding of terminology and acronyms used by ATC and pilots;
- (2) knowledge of the airline call signs used at the aerodrome; and
- (3) knowledge of vehicle call signs, and that they should be appropriate to their function (e.g. 'Operations', 'Fire', 'Engineer') and numbered when more than one vehicle is used (e.g. 'Fire 2').

(e) Read back procedures

The need for vehicle drivers to use standard readback, in the same manner as pilots, for instructions such as 'enter/cross the runway', and if conditional clearances are used.

(f) Readability scale

Understanding and use of the readability scale from 1 to 5.

(g) Lost or uncertain of position

Understanding of local procedures for vehicle drivers lost or uncertain of their position on the manoeuvring area.

(h) Vehicle breakdown

- (1) local procedure for vehicle breakdown on runways and taxiways; and
- (2) procedure for notifying ATC of vehicle failure.

(i) Radio failure

- (1) understanding of the local procedure if radio failure occurs while on the runway or taxiway; and
- (2) understanding of the light signals that can be used by ATC to pass instructions to vehicles.

(j) Transmitting techniques and use of RTF

- (1) understanding the reasons for listening out prior to transmitting;
- (2) use of standard phraseology and ICAO air-ground radiotelephony communications procedures;
- (3) words and sounds to be avoided;
- (4) correct positioning of microphones to avoid voice distortion;
- (5) avoidance of 'clipped' transmissions;
- (6) awareness of regional accents and variations of speech; and
- (7) speed of delivery of RTF phraseology.

(k) Portable radios

- (1) correct use of radios;
- (2) effective range and battery life;

SUBPART B – AERODROME OPERATIONAL SERVICES, EQUIPMENT AND INSTALLATIONS (ADR.OPS.B)

(3) screening/shielding effects on the aerodrome; and

(4) use of correct call signs, either related to a vehicle or a person.

(l) Safety while using radios

(1) local instructions regarding the use of portable radios and hand-held microphones while driving a vehicle; and

(2) local instructions on the use of mobile telephones while operating airside.

GENERAL CONSIDERATIONS

(b) All three training programmes should consist of two main parts, the first being the theoretical part which should include the use of prepared presentations, maps, diagrams, videos, booklets and checklists as appropriate. The second part should involve practical training and visual familiarisation on the aerodrome with a suitably trained person. This practical tuition will take time depending upon the complexity of the aerodrome.

(c) Where the responsibility for vehicle driver training (apron and manoeuvring area) and RTF training is delegated to a third-party provider, the aerodrome management should institute a programme of audits, as part of its safety management system, to ensure that agreed standards are being maintained.

(b)(d) The framework for a vehicle driver training programme outlined above is intended only as a guide, and is based on current 'good practice'. It is incumbent on aerodrome operators to regularly review their vehicle driver training programmes against programmes and documentation available across the industry.

AMC1- ADR.OPS.B.030 – Surface Movement Guidance and Control System^{TRF}
^{REV}movement guidance and control system

GENERAL

(a) The aerodrome operator should develop a surface movement guidance and control system taking into account:

- (1) the density of air traffic;
- (2) the visibility conditions under which operations are intended;
- (3) the need for pilot orientation;
- (4) the complexity of the aerodrome layout; and
- (5) movements of vehicles.

~~(b) The aerodrome operator should ensure that:~~

~~(e)(b)~~ (b) The surface movement guidance and control system is ~~should~~ be designed to assist in the prevention of inadvertent incursions of aircraft and vehicles onto an active runway;

~~(d)(c)~~ (c) The system is ~~should~~ be designed to assist in the prevention of collisions between aircraft, and between aircraft and vehicles or objects, on any part of the movement area.

SUBPART B – AERODROME OPERATIONAL SERVICES, EQUIPMENT AND INSTALLATIONS (ADR.OPS.B)

~~(e)~~(d) ~~The aerodrome operator should ensure that where~~Where a surface movement guidance and control system is provided by selective switching of stop bars and taxiway centre line lights, the following requirements are met:

- (1) taxiway routes which are indicated by illuminated taxiway centre line lights should be capable of being terminated by an illuminated stop bar;
- (2) the control circuits ~~shall~~should be so arranged that when a stop bar located ahead of an aircraft is illuminated, the appropriate section of taxiway centre line lights beyond it is suppressed; and
- (3) the taxiway centre line lights are activated ahead of an aircraft when the stop bar is suppressed.

~~(f)~~(e) The aerodrome operator should develop the surface movement guidance and control system (SMGCS) procedures in cooperation with the aerodrome ~~Air Traffic Service Provider and the major aircraft operators at the aerodrome~~air traffic services provider.

~~GM-GM1~~ **ADR-OPS.B.030** — **Surface ~~Movement Guidance~~movement guidance and Control System**

The SMGC~~control~~ system ~~comprises~~

GENERAL

- (a) The SMGCS system should comprise an appropriate combination of visual aids, non-visual aids, procedures, control, regulation, management and information facilities. Systems range from the very simple at small aerodromes, with light traffic operating in good visibility conditions, to the complex systems necessary at large aerodromes with heavy traffic operating in low visibility conditions. The system selected for an aerodrome will be appropriate to the operational environment in which that aerodrome will operate.
- (b) Surface movement radar for the manoeuvring area ~~may~~could be provided at an aerodrome intended for use in runway visual range conditions less than a value of 350_m.
- (c) Surface movement radar for the manoeuvring area ~~may~~could be provided at an aerodrome other than that in (b) above when traffic density and operating conditions are such that regularity of traffic flow cannot be maintained by alternative procedures and facilities.

~~AMC-AMC1~~ **ADR-OPS.B.035** — **Operations in winter conditions** ^{ADD}

GENERAL

- (a) The aerodrome operator should prepare, in collaboration with ~~ANSP, major aircraft operators~~air traffic services provider and other relevant parties, procedures for winter maintenance (snow plan). The procedures should include requirements for inspections, criteria for snow-clearing, priorities for snow-clearing, criteria for preparation of operational surfaces, requirements for marking of snow-covered operational surfaces.

SUBPART B – AERODROME OPERATIONAL SERVICES, EQUIPMENT AND INSTALLATIONS (ADR.OPS.B)

and methods for assessing and reporting the surface conditions. The criteria specified in the winter maintenance procedures should be minimum criteria for maintaining safe aerodrome operations, ~~incl:including~~ criteria for suspension of runway operation~~;~~.

- (b) The aerodrome operator should ensure that snow, slush, ice, standing water~~,~~ and other contaminants are removed from the surface of a paved runway~~,~~ as rapidly and completely as possible~~,~~ to minimise accumulation~~;~~.
- (c) The aerodrome operator, whenever possible, should ~~not use~~avoid using chemicals which may have harmful effects on aircraft or pavements.

GM1-~~ADR-~~OPS.B.035 — Aerodrome Snow Plan Operations in winter conditionsAERODROME SNOW PLAN

- (a) The aerodrome snow plan ~~is~~should be published and made available to all concerned in snow clearance~~;~~.
- (b) Details of the equipment available at the aerodrome ~~are~~should be published in the Aeronautical Information Publication (AIP~~;~~).
- (c) The aerodrome snow plan ~~may~~should include the following:
 - (1) ~~The~~the Snow Committee members and the person in charge of the snow clearance operation, with a chain of command giving a breakdown in duties;
 - (2) ~~Methods~~methods of communication between aerodrome operations, air traffic control~~,~~ and the Meteorological Office;
 - (3) ~~The~~the equipment available for snow clearance. This should include equipment for ploughing, sweeping~~,~~ and blowing snow;
 - (4) ~~Priority~~priority of surfaces to be cleared~~,~~ and clearance limits for aircraft using the aerodrome;
 - (5) ~~Collection~~collection of information for SNOWTAM and dissemination of this information;
 - (6) ~~Designated~~designated snow dumping or melting areas to avoid confusion during the actual clearance operations;
 - (7) ~~An~~an alerting system in order that sufficient warning ~~to be~~is given to all bodies concerned;
 - (8) ~~The~~the manpower available, including staff for equipment maintenance arrangements for shifts, and call out procedures;
 - (9) ~~Deployment~~deployment of equipment and tactical approaches to be used;
 - (10) ~~general~~General principles to be followed in deciding when to close runways for snow clearance and designation of management personnel authorised to make the decision;
 - (11) ~~Methods~~methods of assessing and reporting the surface conditions; and

(12) Criteriacriteria for the suspension of runway operations.

~~AMC-AMC1~~ ~~ADR-OPS.B.040~~ — ~~Night Operations~~ ^{ADD}

GENERAL

The aerodrome operator for aerodromes operated at night should, in collaboration with air traffic services provider, ensure that visual aids are installed, operated, and maintained to permit aircraft operations to be performed safely.

~~AMC-~~

AMC1 ADR-OPS.B.045 — Low Visibility Operations ^{ADD}GENERAL

- (a) ~~The aerodrome operator should, in collaboration with ANSPs and major aircraft operators at air traffic services provider and the aerodrome provider of apron management services, if applicable, establish procedures for low visibility procedures (LVP) operations if movement of aircraft is permitted when the RVR is less than 550 metres;~~
- (b) ~~(a) Low visibility procedures (LVP) should be approved by the competent authority before implementation; m.~~
- (c) ~~(b) When low visibility procedures (LVP) are in effect, the aerodrome operator should make available to AIS aeronautical information services and/or ATIS air traffic services, as appropriate, information on the status of the aerodrome facilities; n.~~
- (d) ~~(c) The aerodrome operator should establish and implement procedures to ensure that, when low visibility procedures (LVP) are in effect, persons and vehicles operating on an apron are restricted to the essential minimum; o.~~
- (e) ~~(d) The procedures to be established by the aerodrome operator to ensure safe aerodrome operations during low visibility conditions should cover the following subjects:~~
- (1) physical characteristics of the runway environment, including pre-threshold, approach and departure areas;
 - (2) obstacle limitation surfaces;
 - (3) surveillance and maintenance of visual aids ~~compliant to AMC ADR OPS.B.040 (night operations); i~~;
 - (4) safeguarding of non-visual aids essential to low visibility procedures;
 - (5) secondary power supplies;
 - (6) movement area safety;
 - (7) RFFS.

AMC-AMC1 ADR-OPS.B.050 — Operations in adverse weather conditions ^{ADD}PROCEDURES

The aerodrome operator should, together with the ~~ANSPs and major aircraft operators at the aerodrome, air traffic services~~ and other relevant parties operating at the aerodrome, establish and implement procedures required to mitigate the risk of operation of the aerodrome under adverse weather conditions such as strong winds, heavy rain, and thunderstorms, including the suspension of operations on the runway(s) if deemed necessary.

AMC-AMC1 ADR-OPS.B.055 — Fuel ~~quality~~ ^{ADD} qualityGENERAL

SUBPART B – AERODROME OPERATIONAL SERVICES, EQUIPMENT AND INSTALLATIONS (ADR.OPS.B)

The aerodrome operator should ~~ensure~~verify, either by itself or through formal arrangements with third parties, that organisations involved in storing and dispensing of fuel to aircraft, implement procedures to:

- (a) ~~Maintain~~maintain the installations and equipment for storing and dispensing the fuel in such condition so as not to render unfit for use in aircraft;
- (b) ~~Mark~~mark such installations and equipment in a manner appropriate to the grade of the fuel;
- (c) ~~Take~~take fuel samples at appropriate stages during the storing and dispensing of fuel to aircraft, and maintain records of such samples; and
- (d) ~~Use~~use adequately qualified and trained staff in storing, dispensing, and otherwise handling fuel on the aerodrome.

~~GM~~GM1 ADR-OPS.B.055 – Fuel quality

COMPLIANCE

The aerodrome operator, in order to ensure compliance, ~~may~~could use:

- (a) audit reports to organisations involved in storing and dispensing of fuel to aircraft, or
- (b) relevant national procedures providing for the assurance of fuel quality.

~~AMC~~AMC1 ADR-OPS.B.060 – Access to the movement area ~~ADD~~

GENERAL

The aerodrome operator should:

- (a) Establish a system for issuing movement area access authorisations and the conditions of their renewal;
- (b) Define the training syllabus for persons operating at the apron, and on the movement area or other operational areas appropriate to the functions performed;

~~(1) Establish an access control system.~~

~~GM~~

GM1 ADR-OPS.B.060 – Access to the movement area

GENERAL

- (a) Access to the movement area may be granted to persons, provided that:
 - (1) ~~Their~~their duties require access to the movement area; and
 - (2) ~~They~~they have successfully completed a movement area safety training course.
- (b) Access authorisations to persons may be renewed provided that:
 - (1) ~~Their~~their duties require access to the movement area; and

SUBPART B – AERODROME OPERATIONAL SERVICES, EQUIPMENT AND INSTALLATIONS (ADR.OPS.B)

- (2) ~~They~~they have successfully completed a refresher movement area safety training course.
- (c) The movement area safety training ~~may~~should include the following:
 - (1) ~~Aerodrome~~aerodrome familiarisation;
 - (2) ~~Privileges~~privileges of the access authorisations;
 - (3) ~~Apron~~apron markings and signs;
 - (4) ~~Safety~~safety measures; ~~and~~
 - (5) ~~Emergency~~emergency procedures.
- (d) Access authorisations to persons may be suspended or revoked when:
 - (1) ~~Their~~their duties ~~doesn't~~do not require access to the movement area anymore; or
 - (2) ~~They~~they change employer; or
 - (3) ~~They~~they have repeatedly violated the privileges of the access authorisations; or
 - (4) ~~They~~they have repeatedly violated the safety rules on the movement area~~;~~.
- (e) Temporary movement area access authorisations may be granted to persons for a limited period of time provided that:
 - (1) ~~Their~~their duties require access to the movement area for a limited period of time; and
 - (2) ~~They~~they are escorted by persons holding movement area access authorisations~~;~~.

~~AMC-AMC1 ADR-OPS.B.065 – Visual Aids and Aerodrome Electrical Systems~~^{ADD}

GENERAL

- (a) The aerodrome operator should establish a monitoring system of aerodrome ground lights so as to automatically inform the ~~local Air Navigation Service Provider~~air traffic services provider when safe operation is no longer possible~~;~~.
- (b) The aerodrome operator should establish procedures ~~with the ANS provider~~for the ~~provision and~~operation of visual aids~~;~~.
- (c) The aerodrome operator should establish procedures ~~in coordination with the ANS provider~~for the provision and removal of temporary markings, lights and signs.

~~GM-ADR-OPS.B.065~~ — ~~Visual~~ — ~~aids~~

~~The term 'visual aids' includes also apron markings, lighting and visual docking systems.~~

AMC1-ADR-OPS.B.070 — Aerodrome works safety ^{ADD}

GENERAL

- (a) The procedures should be appropriate to the volume and nature of operations at the aerodrome₂.
- (b) Construction or maintenance work on the movement area, or work affecting aerodrome operations should be planned, established, implemented₂ or approved by the aerodrome operator₂.
- (c) The scope of work, physical extent₂ and time period should be notified to concerned relevant parties. If such work will render limitations to the use of a particular runway, additional measures should be implemented to ensure safety₂.
- (d) Roles and responsibilities for operations and tasks associated with the reduction of runway length available and the work in progress (WIP) are clearly understood and complied with₂.
- (e) The aerodrome operator should put in place appropriate measures to monitor the safety of the aerodrome and aircraft operations during aerodrome works such that timely corrective action is taken when necessary to assure continued safe operations₂.
- (f) The aerodrome operator should ensure the works site is returned to operational use in a safe and timely manner by ensuring:
 - (1) ~~The~~the works site is cleared of personnel, vehicles₂ and plant in a safe and timely manner;
 - (2) The works-affected area is inspected for operational serviceability in accordance with the hand-back procedures; and
 - (3) ~~Relevant~~relevant authorities or organisations are notified of the restoration of aerodrome serviceability in accordance with procedures, using suitable means of communication.

AMC2-ADR-OPS.B.070 — ~~Runway pavement overlays~~^{TXF} Aerodrome works safety

RUNWAY PAVEMENT OVERLAYS

The aerodrome operator should ensure that:

- (a) ~~When~~when a runway is to be returned temporarily to an operational status before resurfacing is complete, the longitudinal slope of the temporary ramp, measured with reference to the existing runway surface or previous overlay course, should ~~comply with the applicable CSs; be:~~
 - (1) 0.5 to 1.0 %for overlays up to and including 5 cm in thickness; and

SUBPART B – AERODROME OPERATIONAL SERVICES, EQUIPMENT AND INSTALLATIONS (ADR.OPS.B)

(2) not more than 0.5 % for overlays more than 5 cm in thickness.

- (b) Before a runway being overlaid is returned to a temporary operational status, a runway centre line marking, conforming to the applicable CS specifications included in the aerodrome certification basis of the aerodrome, should be provided.
- (c) The location of any temporary threshold should conform to the applicable CSs identified by a 3.6 m wide transverse stripe.

**AMC3-ADR-OPS.B.070 — Marking and lighting of Unserviceable areas ^{EXT-ADD}
Aerodrome works safety**

MARKING AND LIGHTING OF UNSERVICEABLE AREAS

- (a) The aerodrome operator should ensure that:
- (1) Unserviceability-unserviceability markers are displayed whenever any portion of a taxiway, apron, or holding bay is unfit got for the movement of aircraft but it is still possible for aircraft to bypass the area safely;
 - (2) On a movement area used at night, unserviceability lights should be used; and
 - (3) Unserviceability markers and lights are placed at intervals sufficiently close so as to delineate the unserviceable area.
- (b) Unserviceability markers shall should consist of conspicuous upstanding devices such as flags, cones, or marker boards.
- (c) Unserviceability markers and lights should meet the applicable CS specifications described in CS ADR.DSN.R.870.

GM1-ADR-OPS.B.070 — Routine Maintenance Aerodrome works safety

MAINTENANCE WORKS

- (a) Persons or sections entering the movement area to perform routine-maintenance need to should have a written approval by the aerodrome operator.
- (b) Entrance to the movement area is should be subject to clearance by the unit responsible for that area (ATC, apron management, aerodrome operator, etc.) using appropriate means (R/T, telephone, etc.).
- (c) For individuals Individuals carrying out routine-maintenance duties it is necessary to works should comply with local rules concerning the control and operation of vehicles in the movement area.

GM2-ADR-OPS.B.070 — Minor construction/maintenance work Aerodrome works safety

MINOR CONSTRUCTION/MAINTENANCE WORK

SUBPART B – AERODROME OPERATIONAL SERVICES, EQUIPMENT AND INSTALLATIONS (ADR.OPS.B)

- (a) A system of work permits ~~is necessary~~ should be established for minor works on the movement area~~;~~.
- ~~(b) The actual system employed at each aerodrome is jointly agreed between the aerodrome operator and air traffic control;~~
- ~~(c)~~ (b) The objectives of the work permits ~~are~~ should be such that:
- (1) no work is taking place on the movement area without the knowledge of aerodrome operator's staff and air traffic ~~control~~ services;
 - (2) permitted times of work are strictly followed; and
 - (3) all individuals taking part in the work are briefed in detail on the following:
 - (i) precise areas in which work may be done;
 - (ii) the routes to be followed to and from the working area;
 - (iii) ~~the~~ R/T procedures to be used;
 - (iv) ~~the~~ safety precautions to be observed, the maintenance of a listening watch and the use of look-outs; and
 - (v) the reporting procedure to be followed on completion of work.
- ~~(d)~~ (c) At the conclusion of work, aerodrome operator's staff, or other appropriate staff, ~~is necessary to~~ should inspect the working area to ensure that it has been left in a satisfactory condition.

GM3-ADR-OPS.B.070 —Major Aerodrome works safetyMAJOR CONSTRUCTION/MAINTENANCE WORK

- (a) Examples of major construction ~~/maintenance work~~ activities which may have an impact on safety, and require a prior approval by the Competent Authority, include, but are not limited to, the following:
- (1) development/alteration/extension of aerodrome terminals;
 - (2) development/alteration/extension of hangars;
 - (3) development of new aerodrome control tower;
 - (4) development of any other structure that may have an impact on safety;
 - (5) Etc.
- (b) Before the commencement of any substantial work on the movement area, a liaison group comprising representatives from the ~~Aerodrome Operator, Air Traffic Control~~ aerodrome operator, air traffic services, apron management services, if applicable, and subcontractors' agents ~~may~~ should be established~~;~~.
- (c) The group could meet~~,~~ as often as considered necessary~~,~~ to review progress~~,~~ and consider the need for any change in working practices to meet operational requirements~~;~~.

SUBPART B – AERODROME OPERATIONAL SERVICES, EQUIPMENT AND INSTALLATIONS (ADR.OPS.B)

- (d) As far as practicable, working areas ~~are~~should be blocked off from the active parts of the movement area by the erection of physical barriers~~;~~.
- (e) Consideration should be given to the marking and lighting of barriers~~;~~.
- (f) The lights of taxiways leading into working areas should be permanently 'off'~~;~~.
- (g) Before works commence, the following ~~needs to~~should be established:
 - (1) the hours of work;
 - (2) the authorised routes;
 - (3) the communications facilities to be used;
 - (4) the permitted heights of vehicles and equipment~~,~~. and the limitations to be placed on operating heights of cranes; and
 - (5) any limitation to be placed on use of electrical equipment which might cause interference with navigational facilities or aircraft communications.
- (h) Contractors ~~need to~~should be ~~informed~~briefed for possible hazards to personnel working on aerodromes, in particular the jet blast problem and noise~~;~~.
- (i) Where contractors work on or traverse aircraft pavement areas, these areas ~~needs to~~should be inspected thoroughly before they are opened again for aircraft use, with particular attention to the presence of debris and the general cleanliness of the surface~~;~~.
- (j) Where aircraft are constantly using areas open to contractors, inspections at frequent intervals are required to ensure ~~that the contractor has carried out any necessary cleaning;~~the continuing operational safety of the aerodrome.
- (k) Adequate marking arrangements ~~are~~should be provided for crane jibs when extra conspicuity is considered desirable~~;~~.
- (l) If work is of prolonged duration, a constant watch is required to ensure that the marking and lighting of obstacles and unserviceable areas does not degrade below acceptable limits~~;~~.
- (m) The effect of tall cranes on ILS and radar~~,~~. in conjunction with those responsible for electronic landing aids and steps taken to reduce limitations to the minimum, ~~needs to~~should be considered.

GM4-ADR.OPS.B.070 — Use of unserviceability lights Aerodromes works safety**USE OF UNSERVICEABILITY LIGHTS**

When lights are used to mark temporary unserviceable areas at night or during reduced visibility conditions, these lights mark the most potentially dangerous extremities of the area. A minimum of four such lights could be used, except where the area is triangular in shape where a minimum of three lights may be employed. The number of lights may be increased when the area is large or of unusual configuration. At least one light ~~is~~should be installed for each 7.5 m of peripheral distance of the area. If the lights are directional, they ~~are~~should be orientated so that~~,~~. as far as possible~~,~~. their beams~~,~~. are aligned in the direction from which

SUBPART B – AERODROME OPERATIONAL SERVICES, EQUIPMENT AND INSTALLATIONS (ADR.OPS.B)

aircraft or vehicles will approach. Where aircraft or vehicles will normally approach from several directions, consideration should be given to adding extra lights or using omnidirectional lights to show the area from these directions. Unserviceable area lights should be frangible. Their height should be sufficiently low to preserve clearance for propellers and for engine pods of jet aircraft.

GM5 ADR.OPS.B.070 Aerodrome works safetyWORKS REQUIRING PRIOR COMPETENT AUTHORITY APPROVAL

Examples of works which require an approval are: the construction of new buildings or the expansion of existing buildings at the aerodrome, the construction or relocation of a control tower, etc.

AMC1-~~ADR-~~OPS.B.075 — Safeguarding of aerodromes ^{ADD}GENERAL

- (a) The aerodrome operator should have procedures to monitor the changes in the obstacle environment, marking and lighting, and in human activities or land use on the aerodrome and ~~its surroundings~~ the areas around the aerodrome, as defined in coordination with the Competent Authority. The scope, limits, tasks and responsibilities for the monitoring should be defined in coordination with the relevant ~~ANSair traffic services~~ providers, and with the ~~competent authority~~ Competent Authority and other relevant authorities.
- (b) The limits of the aerodrome surroundings that should be monitored by the aerodrome operator are defined in coordination with the ~~competent authority~~ Competent Authority and should include the areas that can be visually monitored during the inspections of the manoeuvring area.
- (c) The aerodrome operator should have procedures to mitigate the risks associated with changes on the aerodrome and its surroundings identified with the monitoring procedures. The scope, limits, tasks, and responsibilities for the mitigation of risks associated to obstacles or hazards outside the perimeter fence of the aerodrome should be defined in coordination with the relevant ~~ANSair traffic services~~ providers, and with the ~~competent authority~~ Competent Authority and other relevant authorities.
- (d) The risks caused by human activities and land use which should be assessed and mitigated should include:
- (1) obstacles and the possibility of induced turbulence;
 - (2) the use of hazardous, confusing, and misleading lights;
 - (3) the dazzling caused by large and highly reflective surfaces;
 - (4) sources of non-visible radiation, or the presence of moving, or fixed objects which may interfere with, or adversely affect, the performance of aeronautical communications, navigation and surveillance systems; and

SUBPART B – AERODROME OPERATIONAL SERVICES, EQUIPMENT AND INSTALLATIONS (ADR.OPS.B)

- (5) non-aeronautical ground light near an aerodrome which may endanger the safety of aircraft and which should be extinguished, screened, or otherwise modified so as to eliminate the source of danger.

AMC2-GM1 ADR-OPS.B.075 — Obstacle restriction and removal ^{FXT REV}

The aerodrome operator should ensure that, within its area **(a) (1) Safeguarding of responsibility** as defined in AMC1 ADR-OPS.B.075 (b) and (c), obstacles are restricted and removed as follows: **aerodromes**

(1) Objects on runway strips

- (i) An object situated on a runway strip which may endanger aeroplanes should be regarded as an obstacle and should, as far as practicable, be removed;
- (ii) No fixed object, other than visual aids required for air navigation purposes and satisfying the relevant frangibility requirements as defined in the applicable CSs, should be permitted on a runway strip:
- (A) within 77.5 m of the runway centre line of a precision approach runway category I, II or III where the code number is 4 and the code letter is F; or
- (B) within 60 m of the runway centre line of a precision approach runway category I, II or III where the code number is 3 or 4; or
- (C) within 45 m of the runway centre line of a precision approach runway category I where the code number is 1 or 2.
- (iii) No mobile object shall be permitted on this part of the runway strip during the use of the runway for landing or take-off.

(2) Non-precision approach runways

- (i) New objects or extensions of existing objects should not be permitted above an approach surface within 3 000 m of the inner edge or above a transitional surface except when, in the opinion of the appropriate authority, the new object or extension would be shielded by an existing immovable object;
- (ii) New objects or extensions of existing objects should not be permitted above the approach surface beyond 3 000 m from the inner edge, the conical surface or inner horizontal surface except when, in the opinion of the competent authority, the object would be shielded by an existing immovable object, or after aeronautical study it is determined that the object would not adversely affect the safety or significantly affect the regularity of operations of aeroplanes;
- (iii) Existing objects above the conical surface, the inner horizontal surface, the approach surface and the transitional surfaces should as far as practicable be removed except when, in the opinion of the competent authority, the object is shielded by an existing immovable object, or after aeronautical study it is

SUBPART B – AERODROME OPERATIONAL SERVICES, EQUIPMENT AND INSTALLATIONS (ADR.OPS.B)

~~determined that the object would not adversely affect the safety or significantly affect the regularity of operations of aeroplanes.~~

~~(3) Precision approach runways~~

~~(i) Unless its function requires it to be there for air navigation purposes, no equipment or installation should be:~~

~~(A) on a runway strip, a runway end safety area, a taxiway strip or within the distances specified in Table 1, if it would endanger an aircraft; or~~

Code letter	Taxiway, other than aircraft stand taxilane, centre line to object (metres)
A	16.25
B	21.5
C	26
D	40.5
E	47.5
F	57.5

Table 1

~~(B) on a clearway if it would endanger an aircraft in the air.~~

~~(ii) Any equipment or installation required for air navigation purposes which must be located:~~

~~(A) on that portion of a runway strip within:~~

~~(a) 75 m of the runway centre line where the code number is 3 or 4; or~~

~~(b) 45 m of the runway centre line where the code number is 1 or 2; or~~

~~(B) on a runway end safety area, a taxiway strip or within the distances in Table 1; or~~

~~(C) on a clearway and which would endanger an aircraft in the air;~~

~~shall be frangible and mounted as low as possible.~~

~~(iii) Any equipment or installation required for air navigation purposes which must be located on the non-graded portion of a runway strip should be regarded as an obstacle and should be frangible and mounted as low as possible.~~

~~(iv) Unless its function requires it to be there for air navigation purposes, no equipment or installation should be located within 240 m from the end of the strip and within:~~

~~(A) 60 m of the extended centre line where the code number is 3 or 4; or~~

~~(B) 45 m of the extended centre line where the code number is 1 or 2;~~

SUBPART B – AERODROME OPERATIONAL SERVICES, EQUIPMENT AND
INSTALLATIONS (ADR.OPS.B)

~~of a precision approach runway category I, II or III.~~

~~(v) Any equipment or installation required for air navigation purposes which must be located on or near a strip of a precision approach runway category I, II or III and which:~~

~~(A) is situated on that portion of the strip within 77.5 m of the runway centre line where the code number is 4 and the code letter is F; or~~

~~(B) is situated within 240 m from the end of the strip and within:~~

~~(a) 60 m of the extended runway centre line where the code number is 3 or 4; or~~

~~(b) 45 m of the extended runway centre line where the code number is 1 or 2; or~~

~~(C) penetrates the inner approach surface, the inner transitional surface or the balked landing surface;~~

~~should be frangible and mounted as low as possible.~~

~~(vi) Fixed objects should not be permitted above the inner approach surface, the inner transitional surface or the balked landing surface, except for frangible objects which because of their function must be located on the strip. Mobile objects should not be permitted above these surfaces during the use of the runway for landing.~~

~~(vii) New objects or extensions of existing objects should not be permitted above an approach surface or a transitional surface except when, in the opinion of the competent authority, the new object or extension would be shielded by an existing immovable object.~~

~~(viii) New objects or extensions of existing objects should not be permitted above the conical surface and the inner horizontal surface except when, in the opinion of the competent authority, an object would be shielded by an existing immovable object, or after aeronautical study it is determined that the object would not adversely affect the safety or significantly affect the regularity of operations of aeroplanes.~~

~~(ix) Existing objects above an approach surface, a transitional surface, the conical surface and inner horizontal surface should as far as practicable be removed except when, in the opinion of the competent authority, an object is shielded by an existing immovable object, or after aeronautical study it is determined that the object would not adversely affect the safety or significantly affect the regularity of operations of aeroplanes.~~

~~(4) Runways meant for take-off~~

~~(i) New objects or extensions of existing objects should not be permitted above a take-off climb surface except when, in the opinion of the competent authority, the new object or extension would be shielded by an existing immovable object.~~

SUBPART B – AERODROME OPERATIONAL SERVICES, EQUIPMENT AND INSTALLATIONS (ADR.OPS.B)

~~(ii) If no object reaches the 2 % (1:50) take-off climb surface, new objects should be limited to preserve the existing obstacle free surface or a surface down to a slope of 1.6 % (1:62.5).~~

~~(iii) Existing objects that extend above a take-off climb surface should as far as practicable be removed except when, in the opinion of the competent authority, an object is shielded by an existing immovable object, or after aeronautical study it is determined that the object would not adversely affect the safety or significantly affect the regularity of operations of aeroplanes.~~

~~(5) Other objects~~

~~(i) Objects which do not project through the approach surface but which would nevertheless adversely affect the optimum siting or performance of visual or non-visual aids should, as far as practicable, be removed.~~

~~(ii) Anything which may, in the opinion of the competent authority after aeronautical study, endanger aeroplanes on the movement area or in the air within the limits of the inner horizontal and conical surfaces should be regarded as an obstacle and should be removed in so far as practicable.~~

AMC3-ADR-OPS.075 – Marking and lighting of obstacles ^{TXT-REV}

~~(a) The aerodrome operator should ensure that all obstacles penetrating the obstacle limitation surfaces of an aerodrome within its area of responsibility should be marked and/or lighted unless such marking or lighting can be omitted when an aeronautical study shows that marking and/or lighting is not required from a safety view point;~~

~~(b) The aerodrome operator should ensure that fixed objects that extend above an obstacle protection surface within its area of responsibility should be marked and, if the runway is used at night, lighted;~~

~~(c) The aerodrome operator should ensure that elevated aeronautical ground lights within the movement area should be marked so as to be conspicuous by day. Obstacle lights should not be installed on elevated ground lights or signs in the movement area;~~

~~(d) The aerodrome operator should ensure that obstacles within the distance specified in Table 1, from the centre line of a taxiway, an apron taxiway or aircraft stand taxilane should be marked and, if the taxiway, apron taxiway or aircraft stand taxilane is used at night, lighted.~~

Code letter	Taxiway other than aircraft stand taxilane, centre line to object (m)	Aircraft stand taxilane centre line to object (m)
A	16.25	12
B	21.5	16.5
C	26	24.5
D	40.5	36
E	47.5	42.5

F	57.5	50.5
---	------	------

Table 1

~~**AMC4 ADR OPS.B.075 — Obstacles that extends above a take-off climb surface**~~^{TXT-REV}

The aerodrome operator should ensure that fixed obstacles extending above a take-off climb surface within its area of responsibility, should be marked and, if the runway is used at night, lighted, except that:

- (a) such marking and lighting may be omitted when the obstacle is shielded by another fixed obstacle;
- (b) the marking may be omitted when the obstacle is lighted by medium intensity obstacle lights, Type A, by day and its height above the level of the surrounding ground does not exceed 150 m;
- (c) the marking may be omitted when the obstacle is lighted by high intensity obstacle lights by day; and
- (d) the lighting may be omitted where the obstacle is a lighthouse and an aeronautical study indicates the lighthouse light to be sufficient.

~~**AMC5 ADR OPS.B.075 — Objects, other than obstacles, adjacent to a take-off climb surface**~~^{TXT-REV}

The aerodrome operator should ensure that fixed objects, other than obstacles, adjacent to a take-off surface and within its area of responsibility should be marked and, if the runway is used at night, lighted, if such marking and lighting is considered necessary to ensure its avoidance, except that the marking may be omitted when:

- (a) the object is lighted by medium intensity obstacle lights, Type A, by day and its height above the level of the surrounding ground does not exceed 150 m; or
- (b) the object is lighted by high intensity obstacle lights by day.

~~**AMC6 ADR OPS.B.075 — Obstacles that extends above an approach or transitional surface**~~^{TXT-REV}

The aerodrome operator should ensure that fixed obstacles extending above an approach or transitional surface and within its area of responsibility is marked and, if the runway is used at night, lighted, except that:

- (a) such marking and lighting may be omitted when the obstacle is shielded by another fixed obstacle;
- (b) the marking may be omitted when the obstacle is lighted by medium intensity obstacle lights, Type A, by day and its height above the level of the surrounding ground does not exceed 150 m;

SUBPART B – AERODROME OPERATIONAL SERVICES, EQUIPMENT AND
INSTALLATIONS (ADR.OPS.B)

- ~~(c) the marking may be omitted when the obstacle is lighted by high intensity obstacle lights by day; and~~
- ~~(d) the lighting may be omitted where the obstacle is a lighthouse and an aeronautical study indicates the lighthouse light to be sufficient.~~

~~**AMC7 ADR OPS.B.075 — Fixed obstacles above a horizontal surface**~~^{TXT-REV}

~~The aerodrome operator should ensure that fixed obstacles above a horizontal surface and within its area of responsibility are marked and, if the aerodrome is used at night, lighted, except that:~~

- ~~(a) such marking and lighting may be omitted when:
 - ~~(1) the obstacle is shielded by another fixed obstacle; or~~
 - ~~(2) for a circuit extensively obstructed by immovable objects or terrain, procedures have been established to ensure safe vertical clearance below prescribed flight paths; or~~
 - ~~(3) an aeronautical study shows the obstacle not to be of operational significance.~~~~
- ~~(b) the marking may be omitted when the obstacle is lighted by medium intensity obstacle lights, Type A, by day and its height above the level of the surrounding ground does not exceed 150 m;~~
- ~~(c) the marking may be omitted when the obstacle is lighted by high intensity obstacle lights by day; and~~
- ~~(d) the lighting may be omitted where the obstacle is a lighthouse and an aeronautical study indicates the lighthouse light to be sufficient.~~

~~**AMC8 ADR OPS.B.075 — Marking of objects**~~^{TXT-REV}

- ~~(a) The aerodrome operator should ensure that an object within its area of responsibility should be coloured to show a chequered pattern if it has essentially unbroken surfaces and its projection on any vertical plane equals or exceeds 4.5 m in both dimensions; The pattern and the colours should be in accordance with the applicable CSs;~~
- ~~(b) The aerodrome operator should ensure that an object within its area of responsibility should be coloured to show alternating contrasting bands if:
 - ~~(1) it has essentially unbroken surfaces and has one dimension, horizontal or vertical, greater than 1.5 m, and the other dimension, horizontal or vertical, less than 4.5 m; or~~
 - ~~(2) it is of skeletal type with either a vertical or a horizontal dimension greater than 1.5 m.~~~~

~~The dimensions and colours of the bands should be~~OTHER SURFACES TO BE MONITORED

SUBPART B – AERODROME OPERATIONAL SERVICES, EQUIPMENT AND INSTALLATIONS (ADR.OPS.B)

Other surfaces associated with the aerodrome are surfaces that need to be monitored when operating in accordance with ICAO PANS-OPS Doc 8168, Volume II or its equivalent in the national law, when applicable.

GM2 ADR.OPS.B.075 (a) (1) Safeguarding of aerodromes

OTHER AREAS TO BE MONITORED AND PROTECTED

Aeronautical communications, navigation and surveillance systems should be established and protected in accordance with the applicable CSs requirements of ICAO Annex 10.

- ~~(c) The aerodrome operator should ensure that an object within its area of responsibility is coloured in a single conspicuous colour if its projection on any vertical plane has both dimensions less than 1.5 m. Orange or red should be used, except where such colours merge with the background;~~
- ~~(d) The aerodrome operator should ensure that markers displayed on or adjacent to objects within its area of responsibility are located in conspicuous positions so as to retain the general definition of the object and shall be recognizable in clear weather from a distance of at least 1 000 m for an object to be viewed from the air and 300 m for an object to be viewed from the ground in all directions in which an aircraft is likely to approach the object;~~
- ~~(e) Spacing, dimensions and colours of markers should be in accordance with the applicable CSs;~~
- ~~(f) The aerodrome operator should ensure that flags used to mark objects within its area of responsibility are displayed around, on top of, or around the highest edge of, the object. When flags are used to mark extensive objects or groups of closely spaced objects, they should be displayed at least every 15 m. Flags should not increase the hazard presented by the object they mark;~~
- ~~(g) The aerodrome operator should ensure that flags meet the applicable CSs.~~

~~AMC9 ADR OPS.B.075 — Location of obstacle lights~~^{TXF-REV}

~~The aerodrome operator should ensure that the location and characteristics of the obstacle lights within its area of responsibility are in accordance with the applicable CSs for obstacle lights.~~

~~AMC ADR~~

AMC1 ADR.OPS.B.080 — Marking and lighting of vehicles and other mobile objects
^{TXF-REV}

GENERAL

- (a) The aerodrome operator should ensure that all vehicles operating on the manoeuvring area are marked by colours or display flags.

SUBPART B – AERODROME OPERATIONAL SERVICES, EQUIPMENT AND INSTALLATIONS (ADR.OPS.B)

- (b) When mobile objects are marked by colour, a single conspicuous colour, preferably red or yellowish green for emergency vehicles, and yellow for service vehicles, should be used;
- (c) When flags are used to mark mobile objects, they should comply with the applicable CSs;
- (d) Low-intensity obstacle lights, Type C, should be displayed on vehicles and other mobile objects excluding aircraft;
- (e) Low-intensity obstacle lights, Type D, should be displayed on follow-me vehicles.

AMC-AMC1 ADR.OPS.B.085—Handling090 Use of hazardous materials-~~xxx~~**The aerodrome by higher code letter aircraft**ELEMENTS TO BE ASSESSED

When assessing the possibility of operation of aircraft whose code letter is higher than the code letter of the aerodrome reference code, the aerodrome operator should, amongst other issues, assess the impact of the characteristics of the aircraft on the aerodrome, its facilities, equipment and its operation, and vice versa.

Aircraft characteristics to be assessed include, but are not limited to:

~~(s)~~(n) fuselage length;

~~(t)~~(o) fuselage width;

~~(u)~~(p) fuselage height;

~~(v)~~(q) tail height;

~~(w)~~(r) wingspan;

~~(x)~~(s) wing tip vertical clearance;

~~(y)~~(t) cockpit view;

~~(z)~~(u) distance from the pilot's eye position to the nose landing gear and to the main landing gear;

~~(aa)~~(v) landing gear design;

~~(bb)~~(w) outer main gear wheel span;

~~(cc)~~(x) wheelbase;

~~(dd)~~(y) main gear steering system;

(z) landing gear geometry;

(aa) engine data;

(bb) flight performance; and

~~(ee)~~(cc) technology evolution.

~~(a) operator shall ensure that all agents involved in the handling and storing of any hazardous materials comply with the established procedures;~~

~~(b) The procedures shall include at least the following:~~

~~(1) Designated personnel to receive and handle hazardous substances and materials;~~

SUBPART B – AERODROME OPERATIONAL SERVICES, EQUIPMENT AND INSTALLATIONS (ADR.OPS.B)

- ~~(2) Assurance from the shipper that the cargo can be handled safely, including any special handling procedures required for safety;~~
- ~~(3) Special areas for storage of hazardous materials while on the airport.~~

~~GM OPS.B.085 Handling of hazardous materials~~

- ~~(a) The procedure should ensure the safe handling of hazardous materials or dangerous goods on the aerodrome, including:
 - ~~(1) Flammable liquids and solids;~~
 - ~~(2) Corrosive liquids;~~
 - ~~(3) Compressed gases;~~
 - ~~(4) Magnetised or radioactive materials;~~
 - ~~(5) Explosives;~~
 - ~~(6) Biological substances.~~~~
- ~~(b) The aerodrome operator should include the following information in the procedure for handling hazardous materials:
 - ~~(1) Responsibilities of the aerodrome operator and each organisation involved in the handling, storage and transport by air of hazardous materials;~~
 - ~~(2) Applicable regulations, standards and technical references;~~
 - ~~(3) Handling of hazardous materials incidents;~~
 - ~~(4) Handling procedures.~~~~

GM1 ADR.OPS.B.090 Use of the aerodrome by higher code letter aircraft

ELEMENTS TO BE ASSESSED

Further guidance on this issue is contained in ICAO Circular 305-AN/177 and ICAO Circular 301-AN/174.

In any case, the elements that have to be taken into account for the safety assessment are, without prejudice to other assessments that may have to be conducted, in accordance with other applicable requirements contained in Part ADR.OPS.

Such assessments should include, but are not limited to:

- (a) the aircraft mass, tire pressure and ACN values — with regard to overload operations; and
- (b) maximum passenger and fuel carrying capacity — with regard to level of RFFS protection to be provided and the aerodrome emergency planning.

SUBPART C – AERODROME MAINTENANCE**~~AMC-AMC1~~ ADR-OPS.C.005 — General ^{ADD}**MAINTENANCE PROGRAMME

The aerodrome operator should ensure that a maintenance programme is established and implemented, including preventive maintenance where appropriate, to maintain aerodrome facilities in a condition which does not impair the safety of aeronautical operations. The scope of the maintenance programme should include, but may not be limited to, the following items:

- (a) ~~Visual~~visual aids and other lighting systems required for the safety of aerodrome operations;
- (b) ~~Power~~power supply and other electrical systems;
- (c) ~~Pavements~~pavements, other ground surfaces, and drainage systems;
- (d) ~~Fencing~~fencing and other access control devices;
- (e) ~~Equipment~~equipment and vehicles which are necessary for the safety of aerodrome operations; and
- (f) ~~Buildings~~buildings which are necessary for the safety of aerodrome operations.

GM1 ADR.OPS.C.005 GeneralHUMAN FACTORS

The design and application of the maintenance programme should observe human factors principles.

~~AMC-ADR-GM2~~ ADR.OPS.C.005 GeneralMAJOR MAINTENANCE ACTIVITIES

Examples of major maintenance activities that require a prior approval by the Competent Authority include, but are not limited to, the following:

- (a) runway and taxiway resurfacing;
- (b) replacement of the aeronautical ground lighting systems; and
- (c) other maintenance activities that may require the temporary closure of a runway, or a taxiway, or otherwise may disrupt, or have significant effects on aerodrome operation.

AMC1 ADR.OPS.C.010 — Pavements, other ground surfaces, and drainage ^{ADD}GENERAL

- (a) The aerodrome operator should ~~remove mud~~maintain the surface of a paved runway in a condition so as to provide good friction characteristics and low rolling resistance. Mud, dust, sand, oil, rubber deposits, and other pollutants ~~from the surface of a paved runway~~

should be removed, as rapidly and completely as possible, to minimizeminimise accumulation, ~~and not to impair the surface friction characteristics of the runway.~~

- (b) Taxiways and aprons should be kept clear of pollutants to the extent necessary to enable aircraft to be taxied to and from an operational runway.
- (c) Drainage systems and storm water collection systems should be periodically checked and, if necessary cleaned or maintained, to ensure efficient water run-off.
- (d) The aerodrome operator should measure the runway surface friction characteristics for maintenance purpose with a continuous friction measuring device using self-wetting features. The frequency of these measurements should be sufficient to determine the trend of the surface friction characteristics of the runway.
- (e) The aerodrome operator should take corrective maintenance action to prevent the runway surface friction characteristics for either the entire runway, or a portion thereof from falling below the minimum friction level specified by the State.
- (f) When the friction of a significant portion of a runway is found to be below the minimum friction level value, the aerodrome operator should report such information in order to promulgate it in a NOTAM specifying which portion of the runway is below the minimum friction level and its location on the runway, and take immediate corrective action.

AMC-GM1 ADR.OPS.C.010(b)(3) Pavements, other ground surfaces and drainage

DETERMINATION OF FRICTION CHARACTERISTICS OF WET PAVED SURFACES

- (a) The friction of a wet paved runway should be measured to:
 - (1) verify the friction characteristics of new or resurfaced paved runways when wet;
 - (2) assess periodically the slipperiness of paved runways when wet;
 - (3) determine the effect on friction when drainage characteristics are poor; and
 - (4) determine the friction of paved runways that become slippery under unusual conditions.
- (b) Runways should be evaluated when first constructed or after resurfacing, to determine the wet runway surface friction characteristics. Although it is recognised that friction reduces with use, this value will represent the friction of the relatively long central portion of the runway that is uncontaminated by rubber deposits from aircraft operations, and is, therefore, of operational value. Evaluation tests should be made on clean surfaces. If it is not possible to clean a surface before testing, then for purposes of preparing an initial report, a test could be made on a portion of clean surface in the central part of the runway.
- (c) Friction tests of existing surface conditions should be taken periodically in order to identify runways with low friction when wet. When the friction of a runway is found to be below the minimum friction level, then such information should be promulgated by NOTAM. When the friction characteristics for either the entire runway or a portion thereof are below the minimum friction level, corrective maintenance action must be taken without delay. Friction measurements should be taken at intervals that will ensure

SUBPART C – AERODROME MAINTENANCE (ADR.OPS.C)

identification of runways in need of maintenance or special surface treatment before the condition becomes serious. The time interval between measurements will depend on factors such as: aircraft type and frequency of usage, climatic conditions, pavement type, and pavement service and maintenance requirements.

- (d) For uniformity and to permit comparison with other runways, friction tests of existing, new, or resurfaced runways should be made with a continuous friction measuring device provided with a smooth tread tire. The device should have a capability of using self-wetting features to enable measurements of the friction characteristics of the surface to be made at a water depth of, at least, 1 mm.
- (e) When it is suspected that the friction characteristics of a runway may be reduced because of poor drainage, owing to inadequate slopes or depressions, then an additional test should be made, but this time under natural conditions representative of a local rain. This test differs from the previous one in that water depths in the poorly cleared areas are normally greater in a local rain condition. The test results are, thus, more apt to identify problem areas having low friction values that could induce aquaplaning than the previous test. If circumstances do not permit tests to be conducted during natural conditions representative of a rain, then this condition may be simulated.
- (f) Even when the friction has been found to be above the minimum friction level defining a slippery runway, it may be known that under unusual conditions, such as after a long dry period, the runway may have become slippery. When such a condition is known to exist, then a friction measurement should be made as soon as it is suspected that the runway may have become slippery.
- (g) When the results of any of the measurements identified in (c) through (f) above indicate that only a particular portion of a runway surface is slippery, then action to promulgate this information and, if appropriate, take corrective action is equally important.
- (h) When conducting friction tests on wet runways, it is important to note that, unlike compacted snow and ice conditions, in which there is very limited variation of the friction coefficient with speed, a wet runway produces a drop in friction with an increase in speed. However, as the speed increases, the rate at which the friction is reduced becomes less. Among the factors affecting the friction coefficient between the tire and the runway surface, texture is particularly important. If the runway has a good macro-texture allowing the water to escape beneath the tire, then the friction value will be less affected by speed. Conversely, a low macro-texture surface will produce a larger drop in friction with increase in speed. Accordingly, when testing runways to determine their friction characteristics and whether maintenance action is necessary to improve it, a speed high enough to reveal these friction/speed variations should be used.
- (i) The design objective for new runway surfaces and maintenance planning, and minimum friction levels for runway surface in use, should be according to the following table:

Test equipment	Test tire		Test speed (km/h)	Test water depth (mm)	Design objective for new	Maintenance planning level	Minimum friction level
	Type	Pressure (kPa)					

SUBPART C – AERODROME MAINTENANCE (ADR.OPS.C)

					surface		
Mu-meter Trailer	A	70	65	1.0	0.72	0.52	0.42
	A	70	95	1.0	0.66	0.38	0.26
Skiddometer Trailer	B	210	65	1.0	0.82	0.60	0.50
	B	210	95	1.0	0.74	0.47	0.34
Surface Friction Tester Vehicle	B	210	65	1.0	0.82	0.60	0.50
	B	210	95	1.0	0.74	0.47	0.34
Runway Friction Tester Vehicle	B	210	65	1.0	0.82	0.60	0.50
	B	210	95	1.0	0.74	0.54	0.41
TATRA Friction Tester Vehicle	B	210	65	1.0	0.76	0.57	0.48
	B	210	95	1.0	0.67	0.52	0.42
Grip Tester Trailer	B	140	65	1.0	0.74	0.53	0.43
	B	140	95	1.0	0.64	0.36	0.24

Table 1

- (j) Other friction measuring devices can be used, provided they have been correlated with, at least, one test equipment mentioned in the table above.

GM2 ADR.OPS.C.010 (b) (1) Pavements, other ground surfaces, and drainage**OVERLOAD OPERATIONS**

- (a) Overloading of pavements can result either from loads too large, or from a substantially increased application rate, or both. Loads larger than the defined (design or evaluation) load shorten the design life, whilst smaller loads extend it. With the exception of massive overloading, pavements in their structural behaviour are not subject to a particular limiting load above which they suddenly or catastrophically fail. Behaviour is such that a pavement can sustain a definable load for an expected number of repetitions during its design life. As a result, occasional minor overloading is acceptable, when expedient, with only limited loss in pavement life expectancy, and relatively small acceleration of pavement deterioration. For those operations in which magnitude of overload and/or the frequency of use do not justify a detailed analysis, the following criteria are suggested:
- (1) for flexible pavements, occasional movements by aircraft with ACN not exceeding 10 % above the reported PCN should not adversely affect the pavement;
 - (2) for rigid or composite pavements, in which a rigid pavement layer provides a primary element of the structure, occasional movements by aircraft with ACN not exceeding 5 % above the reported PCN should not adversely affect the pavement;
 - (3) if the pavement structure is unknown, the 5 % limitation should apply; and
 - (4) the annual number of overload movements should not exceed approximately 5 % of the total annual aircraft movements.

(b) Such overload movements should not normally be permitted on pavements exhibiting signs of distress or failure. Furthermore, overloading should be avoided during any periods of thaw following frost penetration, or when the strength of the pavement or its subgrade could be weakened by water. Where overload operations are conducted, the aerodrome operator should review the relevant pavement condition regularly, and should also review the criteria for overload operations periodically since excessive repetition of overloads can cause severe shortening of pavement life, or require major rehabilitation of pavement.

GM3 ADR.OPS.C.010 (b) (2) Pavements, other ground surfaces, and drainage

RUNWAY SURFACE EVENNESS

(a) The operation of aircraft and differential settlement of surface foundations will eventually lead to increases in surface irregularities. Small deviations in the above tolerances will not seriously hamper aircraft operations. In general, isolated irregularities of the order of 2.5 cm to 3 cm over a 45 m-distance are tolerable. Although maximum acceptable deviations vary with the type and speed of an aircraft, the limits of acceptable surface irregularities can be estimated to a reasonable extent. The following table describes maximum and temporarily acceptable limits.

	<u>Minimum acceptable length of irregularity (m)</u>								
	<u>3</u>	<u>6</u>	<u>9</u>	<u>12</u>	<u>15</u>	<u>20</u>	<u>30</u>	<u>45</u>	<u>60</u>
<u>Surface Irregularity</u>									
<u>Maximum surface irregularity height (or depth) (cm)</u>	<u>3</u>	<u>3.5</u>	<u>4</u>	<u>5</u>	<u>5.5</u>	<u>6</u>	<u>6.5</u>	<u>8</u>	<u>10</u>
<u>Temporary acceptable surface irregularity height (or depth) (cm)</u>	<u>3.5</u>	<u>5.5</u>	<u>6.5</u>	<u>7.5</u>	<u>8</u>	<u>9</u>	<u>11</u>	<u>13</u>	<u>15</u>

Table 1

If the maximum limits are exceeded, corrective action should be undertaken, as soon as reasonably practicable, to improve the ride quality. If the temporarily acceptable limits are exceeded, the portions of the runway that exhibit such roughness should have corrective measures taken immediately if aircraft operations are to be continued.

- (b) The term ‘-surface irregularity’ is defined herein to mean isolated surface elevation deviations that do not lie along a uniform slope through any given section of a runway. For the purposes of this concern, a ‘section of a runway’ is defined herein to mean a segment of a runway throughout which a continuing general uphill, downhill, or flat slope is prevalent. The length of this section is generally between 30 and 60 m, and can be greater, depending on the longitudinal profile and the condition of the pavement.
- (c) Deformation of the runway with time may also increase the possibility of the formation of water pools. Pools as shallow as approximately 3 mm in depth, particularly if they are located where they are likely to be encountered at high speed by landing aeroplanes, can induce aquaplaning which can then be sustained on a wet runway by a much shallower depth of water. Improved guidance regarding the significant length and depth of pools relative to aquaplaning is the subject of further research. It is, of course, especially necessary to prevent pools from forming whenever there is a possibility that they might become frozen.
- (d) Macrotexture and microtexture are taken into consideration in order to provide the required surface friction characteristics. This normally requires some form of special surface treatment.

AMC1 ADR.OPS.C.015 — ~~Visual Aids~~ and ~~Electrical Systems~~^{ADD} electrical systems

GENERAL

- (a) The aerodrome operator should establish a system of corrective and preventive maintenance which ensures that a light is deemed unserviceable when the main beam average intensity is less than 50-% of the value specified in the applicable CSs. For light units where the designed main beam average intensity is above the specified in the applicable CSs, the 50-% value ~~shall~~should be related to that design value~~;~~.
- (b) The aerodrome operator should establish a system of preventive maintenance of visual aids to ensure lighting and marking system reliability and serviceability as required for the intended operations.