

Certification Specifications for European Technical Standard Orders (CS-ETSO)

Amendment 16

23 July 2020¹

¹ For the date of entry into force of this Amendment, please refer to Decision 2020/011/R at the [Official Publication](#) of EASA.

TABLE OF CONTENTS

Table of contents	2
Preamble 6	
SUBPART A – GENERAL.....	7
SUBPART B — LIST OF ETSOs	12
Index 1	22
ETSO-C10c	22
Pressure Altimeter System	22
Appendix 1 to ETSO-C10c – Minimum Performance Standard (MPS) for Pressure Altimeter Systems	24
ETSO-C13g	26
Life Preservers	26
Appendix 1 to ETSO-C13g – Functional and Environmental Qualification Requirements ..	28
Appendix 2 to ETSO-C13g – Tests Involving Subjects*	36
ETSO-C20a	38
Combustion Heaters and accessories.....	38
Appendix 1 to ETSO-C20a – MPS for Combustion Heater Based on SAE AS8040B	40
Appendix 2 to ETSO-C20a – Instructions for Continued Airworthiness of the Aircraft Combustion Heater and Accessories	43
ETSO-C27a	44
Twin Seaplane Floats	44
ETSO-C43d.....	46
Temperature Instruments	46
Appendix 1 to ETSO-C43d – Modifications to SAE AS8005A.....	48
ETSO-C113b.....	49
Airborne Multipurpose Electronic Displays.....	49
Appendix 1 to ETSO-C113b – Colour.....	51
ETSO-C117b.....	52
Airborne Wind shear Warning and Escape Guidance Systems (Reactive Type) for Transport Aeroplanes.....	52
Appendix 1 to ETSO-C117b – EASA Performance Standard for Airborne Wind Shear Warning and Escape Guidance Systems for Transport Aeroplanes	54
Appendix 2 to ETSO-C117b – Wind Field Models and Data.....	73
Appendix 3 to ETSO-C117b – Wind Field Model Coordinate System Transformation	85
Appendix 4 to ETSO-C117b – Dryden Turbulence and Discrete Gust Model.....	87
Appendix 5 to ETSO-C117b – Shear Intensity	89
Appendix 6 to ETSO-C117b – Wind Shear Simulation Model	90

ETSO-C126c	114
Locator Transmitter	114
ETSO-C142b	116
Non-Rechargeable Lithium Cells and Batteries	116
Appendix 1 to ETSO-C142b – Minimum Performance Standard for Lithium Batteries ...	118
ETSO-C145e A1	121
Airborne Navigation Sensors Using the Global Positioning System Augmented by the Satellite-Based Augmentation System	121
Appendix 1 to ETSO-C145e A1 – End-Use Equipment Manufacturer Tests for SBAS CCA Functional Position, Velocity, Time (PVT) Sensors Used for Navigation and Non-Navigation Applications	125
Appendix 2 to ETSO-C145e A1 – Addition to RTCA Document DO-229E Section 1	130
Appendix 3 to ETSO-C145e A1	132
Appendix 4 to ETSO-C145e A1	133
ETSO-C146e A1	134
Stand-Alone Airborne Navigation Equipment Using the Global Positioning System Augmented by the Satellite-Based Augmentation System	134
Appendix 1 to ETSO-C146e A1– End-Use Equipment Manufacturer Tests after Integration of Delta CCA Functional Sensors Used for Navigation Applications	138
Appendix 2 to ETSO-C146e A1 – Addition to RTCA Document DO-229E, Section 1	143
Appendix 3 to ETSO-C146e A1	148
Appendix 4 to ETSO-C146e A1	149
ETSO-C151d	150
Terrain Awareness and Warning System (TAWS)	150
ETSO-C153a	153
Integrated Modular Avionics (IMA) Platform and Modules	153
Appendix 1 to ETSO-C153a – Integrated Modular Avionics (IMA) Overview, Definition and Examples	157
Appendix 2 to ETSO-C153a – Integrated Modular Avionics (IMA) Module Minimum Performance Standard (MPS)	165
Appendix 2.1 to ETSO-C153a – Integrated Modular Avionics (IMA) Module Minimum Performance Standard (MPS)	167
Appendix 2.2 to ETSO-C153a – Integrated Modular Avionics (IMA) Platform and Module Minimum Performance Standard (MPS).....	180
Appendix 2.3 to ETSO-C153a – Integrated Modular Avionics (IMA) Platform and Module Minimum Performance Standard (MPS).....	192
Appendix 2.4 to ETSO-C153a – Integrated Modular Avionics (IMA) Module Minimum Performance Standard (MPS)	196
Appendix 2.5 to ETSO-C153a – Integrated Modular Avionics (IMA) Platform and Module Minimum Performance Standard (MPS).....	200
Appendix 2.6 to ETSO-C153a – Integrated Modular Avionics (IMA) Module Minimum Performance Standard (MPS)	203
Appendix 2.7 to ETSO-C153a – Integrated Modular Avionics (IMA) Platform and Module Minimum Performance Standard (MPS).....	207
Appendix 2.8 to ETSO-C153a – Integrated Modular Avionics (IMA) Platform and Module Minimum Performance Standard (MPS).....	211
Appendix 3 to ETSO-C153a – Integrated Modular Avionics (IMA) Module Data Requirements.....	215

Appendix 4 to ETSO-C153a – Integrated Modular Avionics (IMA) Module Environmental Qualification Requirements	219
ETSO-C159d	224
Next Generation Satellite Systems (NGSS) Equipment	224
ETSO-C165b	230
Electronic Map Systems for Graphical Depiction of Aircraft Position	230
ETSO-C168	233
Aviation Visual Distress Signals	233
ETSO-C179b	235
Rechargeable Lithium Cells, Batteries, and Battery Systems	235
ETSO-C196b	237
Airborne Supplemental Navigation Sensors for Global Positioning System Equipment Using Aircraft-Based Augmentation	237
Appendix 1 to ETSO-C196b – End-Use Equipment Manufacturer Tests for GNSS CCA functional PVT Sensors Used for Navigation and Non-Navigation Applications.....	240
ETSO-C199 A1	245
Traffic Awareness Beacon System (TABS)	245
Appendix 1 to ETSO-C199 A1 – Traffic Awareness Beacon System (TABS) Requirements.....	249
Appendix 2 to ETSO C-199 A1 – Test Requirements	263
Appendix 3 to ETSO-C199 A1 – Environmental Testing for Class B Equipment	276
ETSO-C207a	278
Aeronautical Mobile Airport Communication System (AeroMACS).....	278
ETSO-C209	280
Electronic Flight Instrument System (EFIS) Display	280
ETSO-C210	282
Airborne Head-Up Display	282
ETSO-C214 A1	284
Functional ETSO Equipment using AN ETSO-2C153a-Authorised IMA Platform or Module	284
Appendix 1 to ETSO-C214 A1 – ‘Open’ class IMA equipment.....	291
Index 2	293
ETSO-2C19c A1	293
Portable Water-solution Type Hand Fire Extinguishers	293
Appendix 1 to ETSO-2C19c A1 – MPS Portable Water Solution Type Hand Fire Extinguishers	295
ETSO-2C123c	296
Cockpit Voice Recorder Systems	296
Appendix 1 to ETSO-2C123c – MPS for Crash-Protected Airborne Recorder Systems	298
ETSO-2C124c	299
Flight Data Recorder Systems.....	299
Appendix 1 to ETSO-2C124c – MPS FOR CRASH-PROTECTED AIRBORNE RECORDER SYSTEMS	301
ETSO-2C176a	303

Aircraft Cockpit Image Recorder Systems	303
Appendix 1 to ETSO-C176a – MPS for Crash-Protected Airborne Recorder Systems	305
ETSO-2C177a	307
Data Link Recorder Equipment.....	307
Appendix 1 to ETSO-C2177a – MPS for Crash-Protected Airborne Recorder Systems.....	309
ETSO-2C197 A1	311
Information Collection and Monitoring Systems	311
ETSO-2C204a	313
Circuit Card Assembly (CCA) Functional Sensors Using Satellite-Based Augmentation Systems (SBASs) for Navigation and Non-Navigation Position/Velocity/Time (PVT) Output	313
Appendix 1 to ETSO-2C204a – Addition to RTCA Document DO-229E	320
Appendix 2 to ETSO-2C204a – Addition to RTCA Document DO-229E	322
Appendix 3 to ETSO-2C204a	323
ETSO-2C205a	324
Circuit Card Assembly (CCA) Functional Class Delta Equipment Using THE Satellite-Based Augmentation Systems (SBASs) for Navigation APPLICATIONS	324
Appendix 1 – Addition to RTCA DO-229E.....	331
Appendix 2	333
Appendix 3	334
ETSO-2C206	335
Circuit Card Assembly (CCA) Functional Sensors Using THE aircraft-Based Augmentation for Navigation and Non-Navigation Position/Velocity/Time (PVT) Output	335
ETSO-2C515 A1	341
Aircraft Halocarbon Clean Agent HandHeld Fire Extinguisher	341
Appendix 1 to ETSO-2C515 A1 – Halocarbon Clean Agent Handheld Fire Extinguisher ...	343
Appendix 2 to ETSO-2C515 A1 – Halocarbon Clean Agent Handheld Fire Extinguisher ...	344
ETSO-2C517	345
Automatic Deployable Flight Recorder (ADFR) Systems for Large Aeroplanes.....	345
Appendix 1 to ETSO-2C517 – Minimum Operational Performance Standard (MOPS) for Automatic Deployable Flight Recorder (ADFR) Systems.....	347
Appendix 2 to ETSO-2C517 – Distances Required for the Deceleration of the Automatic Deployable Package	360
ETSO-2C518	363
Runway Overrun Awareness and Alerting Systems	363
ETSO-2C519	364
Emergency Breathing Systems (EBSs)	364

PREAMBLE

*ED Decision 2020/011/R***Amendment 16**

The following is a list of paragraphs affected by this amendment:

Subpart A — Paragraphs 1, 2.1, 2.2, 2.3, 2.4, and 2.5	Amended
Subpart A — Paragraphs 2.7 and 2.8	Newly introduced
INDEX 1	
ETSO-C10c	Amended
ETSO-C13g	Amended
ETSO-C20a	Amended
ETSO-C27a	Amended
ETSO-C43d	Amended
ETSO-C113b	Amended
ETSO-C117b	Amended
ETSO-C126c	Amended
ETSO-C142b	Amended
ETSO-C145e A1	Amended
ETSO-C146e A1	Amended
ETSO-C151d	Amended
ETSO-C153a	Amended
ETSO-C159d	Amended
ETSO-C160a A1	Amended
ETSO-C165b	Amended
ETSO-C168	Newly introduced
ETSO-C179b	Amended
ETSO-C196b	Amended
ETSO-C199 A1	Amended
ETSO-C207a	Amended
ETSO-C214 A1	Amended
INDEX 2	
ETSO-2C19c A1	Amended
ETSO-2C123c	Amended
ETSO-2C124c	Amended
ETSO-2C176a	Amended
ETSO-2C177a	Amended
ETSO-2C197 A1	Amended
ETSO-2C204a	Amended
ETSO-2C205a	Amended
ETSO-2C206	Amended
ETSO-2C515 A1	Amended
ETSO-2C517	Newly introduced
ETSO-2C518	Newly introduced
ETSO-2C519	Newly introduced

SUBPART A – GENERAL

ED Decision 2020/011/R (applicable from 25.7.2020)

1. APPLICABILITY

- 1.1 Requirements for the issue of European Technical Standard Order (ETSO) authorisations are found in Part 21, Section A, Subpart O.
- 1.2 Marking requirements for the issue of European Technical Standard Order (ETSO) authorisations are found in Part 21, Section A, Subpart Q.

2. STANDARDS TO MEET TECHNICAL CONDITIONS

2.1 Environmental standards

Unless otherwise stated in paragraph 3.1.2 of the specific ETSO, the applicable environmental standards are contained in EUROCAE/RTCA document ED-14D, Change 3/DO-160D 'Environmental Conditions and Test Procedures for Airborne Equipment', Change 3, dated December 2002, ED-14E/DO-160E dated March 2005, ED-14F/DO-160F dated March 2008, ED-14G/DO-160G dated December 2010, or ED-14G Change 1/DO-160G Change 1 dated January 2015.

Compliance shall be demonstrated entirely with one of the above versions of the applicable environmental standards.

2.2 Software

If the ETSO article includes the software shall be developed with development assurance. The accepted means of compliance for the development assurance of airborne software is contained in the revision of AMC 20-115, entitled 'Airborne Software Development Assurance using EUROCAE ED-12 and RTCA document DO-178', that is current at the time of the application, or in any later revision. The use of any other means of compliance shall be subject to a deviation request.

The software level, also known as the 'item development assurance level (IDAL)', should be determined by using the guidance proposed in Section 2.4. The applicant must declare the software level(s) to which the software has been developed and verified.

2.3 Airborne electronic hardware (AEH)

If the ETSO article includes airborne electronic hardware, the airborne electronic hardware shall be developed with development assurance. The accepted means of compliance for the development of airborne electronic hardware is contained in the revision of AMC 20-152¹, entitled 'Development Assurance for Airborne Electronic Hardware' that is current at the time of the application, or in any later revision. The use of any other means of compliance shall be subject to a deviation request.

The hardware development assurance level (DAL), also known as the 'item development assurance level (IDAL)', should be determined by using the guidance proposed in Section 2.4. The applicant must declare the hardware DAL(s) to which it has been developed and verified.

2.4 Failure conditions classification and development assurance

During the development of an ETSO article, consideration should be given to failure conditions, and the ETSO article should then be developed in accordance with the

¹ Refer to ED Decision 2020/010/R (<https://www.easa.europa.eu/document-library/agency-decisions>).

possible effects of those failure conditions at the system and aircraft levels (see, for instance, AMC CS xx.1309 or AMC CS 23.2500/2510 for further guidance).

The ETSO article shall be developed according to at least the development assurance level that is appropriate to the failure condition classifications that are expected for the intended installation.

If the effects at the system or aircraft level are not known, due to the non-availability of aircraft or system design data, the applicant should make and declare an assumption for the failure classification. The assumed failure classification should be at least as high as the minimum hazard classification level required in the ETSO.

The classification of failure conditions at the level of the ETSO article may change as a result of particular aircraft installation architectures and characteristics.

EUROCAE/SAE document ED-79A/ARP 4754A, 'Guidelines for Development of Civil Aircraft and Systems', dated December 2010, should be used to assign the development assurance levels of the ETSO article, software and AEH. The document should also be used as guidance to ensure that a proper development, validation and verification process is followed for the ETSO article and its functional requirements.

2.5 ETSO article using an [ETSO-C153\(\)](#)-authorised IMA platform or module

If the ETSO article implements one (or several) [ETSO-C153\(\)](#)-authorised integrated modular avionics (IMA) platforms/modules and the applicant seeks compliance credit from this (these) ETSOA authorisation(s) to demonstrate compliance with one or several functional ETSO standard(s), the applicant shall apply for authorisation to the [ETSO-C214](#) standard, together with the intended functional ETSO standard(s).

Note: A functional ETSO standard is any ETSO standard of CS-ETSO that describes an 'aircraft' function, i.e. typically any ETSO standard, except [ETSO-C153\(\)](#) and [ETSO-C214](#).

2.6 Information security protection

An ETSO article may be designed with a security assurance level (SAL) that is appropriate for specified security measures, according to the procedure provided in AMC 20-42.

2.7 Open problem reports (OPRs)

Problem reports that are related to ETSO articles that contain software or airborne electronic hardware shall be identified and managed. The accepted means of compliance for the management of OPRs is contained in the revision of AMC 20-189¹ 'Management of Open Problem Reports' that is current at the time of application, or in any later revision. The use of any other means of compliance shall be subject to a deviation request.

2.8 Embedded batteries

If an ETSO article embeds a lithium battery whose energy is equal to or greater than 2 Wh, the battery shall be approved in accordance with the applicable battery ETSO. Additionally, when the battery ETSO covers the article embedding the battery, the article shall also be approved in accordance with the applicable battery ETSO.

For rechargeable lithium batteries whose energy is less than 2 Wh, the battery shall comply with the UN Recommendations on the Transport of Dangerous Goods - Model

¹ Refer to ED Decision 2020/010/R (<https://www.easa.europa.eu/document-library/agency-decisions>).

Regulations and shall be certified to UL 1642, UL 2054 or IEC 62133, unless it is shown to meet the requirements of RTCA document DO-311A Energy Category 2.

For non-rechargeable lithium batteries whose energy is less than 2 Wh, the battery shall be certified to UL 1642 and shall comply with the UN Recommendations on the Transport of Dangerous Goods - Model Regulations.

If there is no ETSO that is applicable to a particular battery that an applicant intends to use in an ETSO article, the applicant should contact EASA.

3. ADDITIONAL INFORMATION

3.1 In some ETSOs, reference is made to an associated FAA standard. In these cases, the corresponding FAA technical standard order (TSO) can be consulted on http://rgl.faa.gov/Regulatory_and_Guidance_Library/rgTSO.nsf/Frameset?OpenPage.

3.2 Standards documents referred to in this CS-ETSO may be purchased or obtained from the following organisations:

— ASD-STAN documents:

AeroSpace and Defence Industries Association of Europe – Standardization
Rue Montoyer 10 - 1000 Brussels
(Email: sales@asd-stan.org, website: www.asd-stan.org)

— ASTM documents:

American Society for Testing and Materials, ASTM International,
100 Barr Harbor Drive, PO Box C700, West Conshohocken, Pennsylvania
19428-2959, USA
(Website: www.astm.org)

— ETSI European Telecommunications Standards Institute

650, Route des Lucioles
06560 Valbonne - Sophia Antipolis
FRANCE
Telephone: +33 4 92 94 42 00
([https://www.etsi.org/standards#Pre-defined Collections](https://www.etsi.org/standards#Pre-defined_Collections))

— EUROCAE documents:

European Organisation for Civil Aviation Equipment
9-23 rue Paul Lafargue, “Le Triangle” building, 93200 Saint-Denis, France
Telephone: +33 1 49 46 19 65
(Email: eurocae@eurocae.net, website: www.eurocae.net)

— EUROCONTROL Surveillance Document Library:

<https://www.eurocontrol.int/articles/surveillance-library>

— FAA standards:

Superintendent of Documents, Government Printing Office

732N Capitol Street NW, Washington DC 20401, USA

(Website: www.gpoaccess.gov)

— FCC Documents:

<http://www.fcc.gov>

— Global System, Inc., documents:

Global Systems, Inc., 2144 Michelson Drive, Irvine, California 92715, USA

Telephone: (714) 851-0119

— International Electrotechnical Commission

<https://webstore.iec.ch>

— MIL specifications:

DODSSP, Standardization Documents Order Desk

Building 4D, 700 Robbins Avenue, PHILADELPHIA, PA 19111-5094, USA

or from the ASSIST Customer Service Desk, telephone (215) 697-6396

(Website: <http://quicksearch.dla.mil/>)

— NAS specifications:

Aerospace Industries Association (AIA)

1327 Jones Drive, Ann Arbor, MI 48105, USA

(Website: www.techstreet.com)

— RTCA documents:

Radio Technical Commission for Aeronautics, Inc.

1828 L Street NW, Suite 805, Washington DC 20036, USA

(Website: www.rtca.org)

— SAE documents:

Society of Automotive Engineers, Inc.

400 Commonwealth Drive, WARRENDALE, PA 15096-001, USA

(Website: www.sae.org)

— UN United Nations Economic Commission for Europe transport regulations:

United Nations Bookshop

GA-1B-103

New York, NY 10017

USA

Tel: +1-212-963-7680

Email: bookshop@un.org

(Website:

https://www.unece.org/trans/danger/publi/unrec/rev13/13nature_e.html)

— UL Underwriters Laboratory standards:

([website: https://standardscatalog.ul.com](https://standardscatalog.ul.com))

[Amdt ETSO/3]

[Amdt ETSO/6]

[Amdt ETSO/7]

[Amdt ETSO/8]

[Amdt ETSO/12]

[Amdt ETSO/14]

[Amdt ETSO/15]

[Amdt ETSO/16]

SUBPART B — LIST OF ETSOs

ED Decision 2020/011/R (applicable from 25.7.2020)

This Subpart contains two Indexes:

1 INDEX 1

- 1.1 Index 1 lists all those ETSOs which are technically similar to FAA-TSOs.
- 1.2 When an article has been approved by the Agency to an ETSO listed in Index 1 the article is to be permanently marked with the appropriate ETSO number. Also, all documentation associated with Certification and Release for installation on an aeroplane must record this ETSO number. The 'E' Symbol signifies that the article has been certified to the relevant ETSO by the Agency.
- 1.3 Index 1 lists all those ETSOs whose functional requirements are equivalent to those of the corresponding FAA TSOs that have the same identification numbers.
- 1.4 Reserved
- 1.5 The ETSO numbering system is explained as follows:
 - ETSO-C5e means: European TSO-Number and revision letter, and so
 - ETSO-C95 with no revision letter means initial issue.

NOTE: Copies of ETSOs are listed in Index 1.

2 INDEX 2

- 2.1 Index 2 lists all those ETSOs which are not technically similar to the FAA-TSOs. Index 2 ETSOs are identified by '2C' prefixes, and numbered as follows:
 - (a) An ETSO with significant differences in the MOPS in comparison with the corresponding FAA TSO is identified by the same number as the corresponding FAA TSO (related to the same type of equipment) with a number in the range from ETSO-2C1 to ETSO-2C499; or
 - (b) An ETSO for which there is no corresponding FAA TSO (related to the same type of equipment) is identified by a number in sequence from ETSO-2C500 upwards.

Index 1

EASA ETSO ref.	Title	Last amended by
ETSO-C1e	Cargo Compartment Fire Detection Instruments	CS-ETSO/13
ETSO-C2d	Airspeed Instruments	CS-ETSO/Initial Issue
ETSO-C3e	Turn and Slip Instruments	CS-ETSO/11
ETSO-C4c	Bank and Pitch Instruments	CS-ETSO/Initial Issue
ETSO-C5f	Direction Instrument, Non-Magnetic (Gyroscopically Stabilized)	CS-ETSO/11
ETSO-C6e	Direction Instrument, Magnetic (Gyroscopically Stabilized)	CS-ETSO/6
ETSO-C7d	Direction Instrument, Magnetic Non-Stabilized Type (Magnetic Compass)	CS-ETSO/Initial Issue
ETSO-C8e	Vertical Velocity Instrument (Rate-of-Climb)	CS-ETSO/6
ETSO-C10c	Pressure Altimeter System	CS-ETSO/16
ETSO-C13g	Life preservers	CS-ETSO/16
ETSO-C14b	Aircraft Fabric, Intermediate Grade; External Covering Material	CS-ETSO/Initial Issue
ETSO-C15d	Aircraft Fabric, Grade A; External Covering Material	CS-ETSO/Initial Issue
ETSO-C16b	Electrically Heated Pitot and Pitot-Static Tubes	CS-ETSO/13
ETSO-C20a	Combustion Heaters and Accessories	CS-ETSO/16
ETSO-C21b	Aircraft Turnbuckle Assemblies and/or Turnbuckle Safetying Devices	CS-ETSO/Initial Issue
ETSO-C22g	Safety Belts	CS-ETSO/Initial Issue
ETSO-C23f	Personal Parachute Assemblies and Components	CS-ETSO/13
ETSO-C25a	Aircraft Seats and Berths (Type I Transport 6g Forward Load)	CS-ETSO/Initial Issue
ETSO-C26d	Aircraft Wheels and Wheel-Brake Assemblies (CS-23, 27 and 29 aircraft)	CS-ETSO/12
ETSO-C27a	Twin Seaplane Floats	CS-ETSO/16
ETSO-C28	Aircraft Skis	CS-ETSO/Initial Issue
ETSO-C30d	Aircraft Position Lights	CS-ETSO/13
ETSO-C39c	Aircraft Seats and Berths Certified by Static Testing only	CS-ETSO/6

EASA ETSO ref.	Title	Last amended by
ETSO-C42	Propeller Feathering Hose Assemblies	CS-ETSO/Initial Issue
ETSO-C43d	Temperature Instruments	CS-ETSO/16
ETSO-C44c A1	Fuel Flowmeters	CS-ETSO/8
ETSO-C45b A1	Manifold Pressure Instruments	CS-ETSO/8
ETSO-C46a	Maximum Allowable Airspeed Indicator System	CS-ETSO/Initial Issue
ETSO-C47a A1	Pressure Instruments — Fuel, Oil, and Hydraulic (Reciprocating Engine-Powered Aircraft)	CS-ETSO/8
ETSO-C49b	Electric Tachometer: Magnetic Drag (Indicator and Generator)	CS-ETSO/Initial Issue
ETSO-C53a	Fuel and Engine Oil System Hose Assemblies	CS-ETSO/Initial Issue
ETSO-C54	Stall Warning Instruments	CS-ETSO/Initial Issue
ETSO-C55a	Fuel and Oil Quantity Instruments	CS-ETSO/7
ETSO-C56b A1	Engine-Driven Direct Current Generators/Starter Generators	CS-ETSO/8
ETSO-C59b	Airborne Selective Calling Equipment	CS-ETSO/13
ETSO-C62e	Aircraft Tyres	CS-ETSO/7
ETSO-C63e	Airborne Weather Radar Equipment	CS-ETSO/13
ETSO-C64b	Oxygen Mask Assembly, Continuous Flow, Passenger	CS-ETSO/12
ETSO-C69c	Emergency Evacuation Slides, Ramps and Slide/Rafts Combinations	CS-ETSO/Initial Issue
ETSO-C70b	Life Rafts	CS-ETSO/11
ETSO-C71	Airborne Static ('DC to DC') Electrical Power Converter (for Air Carrier Aircraft)	CS-ETSO/Initial Issue
ETSO-C72c	Individual Flotation Devices	CS-ETSO/Initial Issue
ETSO-C73	Static Electrical Power Inverter	CS-ETSO/Initial Issue
ETSO-C76b	Fuel Drain Valves	CS-ETSO/11
ETSO-C78a	Crewmember Demand Oxygen Mask	CS-ETSO/13
ETSO-C79	Fire Detectors (Radiation Sensing Types)	CS-ETSO/Initial Issue
ETSO-C80	Flexible Fuel and Oil Cell Material	CS-ETSO/Initial Issue

EASA ETSO ref.	Title	Last amended by
ETSO-C85b	Survivor Locator Lights	CS-ETSO/12
ETSO-C87a	Airborne Low-Range Radio Altimeter	CS-ETSO/8
ETSO-C88b	Automatic Pressure Altitude Reporting Code Generating Equipment	CS-ETSO/11
ETSO-C89a	Crew Member Oxygen Regulators, Demand	CS-ETSO/11
ETSO-C90d A1	Cargo Pallets, Nets and Containers	CS-ETSO/11
ETSO-C92c	Ground Proximity Warning, Glide Slope Deviation Alerting Equipment	CS-ETSO/Initial Issue
ETSO-C95a	Mach Meters	CS-ETSO/7
ETSO-C96b	Anticollision Light Systems	CS-ETSO/13
ETSO-C99a	Flight Deck (Sedentary) Crew Member Protective Breathing Equipment	CS-ETSO/11
ETSO-C100c	Aviation Child Safety Device (ACDS)	CS-ETSO/11
ETSO-C101	Overspeed Warning Instruments	CS-ETSO/Initial Issue
ETSO-C102	Airborne Radar Approach and Beacon Systems for Helicopters	CS-ETSO/Initial Issue
ETSO-C103	Continuous Flow Oxygen Mask Assembly (for Non-Transport Category Aircraft)	CS-ETSO/Initial Issue
ETSO-C105	Optional Display Equipment for Weather and Ground Mapping Radar Indicators	CS-ETSO/Initial Issue
ETSO-C106 A1	Air Data Computer	CS-ETSO/8
ETSO-C109	Airborne Navigation Data Storage System	CS-ETSO/Initial Issue
ETSO-C110a	Airborne Passive Thunderstorm Detection Systems	CS-ETSO/Initial Issue
ETSO-C112e	Secondary Surveillance Radar Mode S Transponder	CS-ETSO/11
ETSO-C113b	Airborne Multipurpose Electronic Displays	CS-ETSO/16
ETSO-C114 A1	Torso Restraint Systems	CS-ETSO/8
ETSO-C115d	Required Navigation Performance (RNP) Equipment using Multi-Sensor Inputs	CS-ETSO/13
ETSO-C116a	Crew Member Portable Protective Breathing Equipment	CS-ETSO/11

EASA ETSO ref.	Title	Last amended by
ETSO-C117b	Airborne Wind Shear Warning and Escape Guidance Systems (Reactive Type) for Transport Aeroplanes	CS-ETSO/16
ETSO-C118a	Traffic Alert and Collision Avoidance System I (TCAS I)	CS-ETSO/13
ETSO-C119d	Airborne Collision Avoidance System II (ACAS II) Version 7.1 with Hybrid Surveillance	CS-ETSO/11
ETSO-C121b	Underwater Locating Device	CS-ETSO/8
ETSO-C126c	Emergency Locator Transmitter	CS-ETSO/16
ETSO-C127b	Rotorcraft, Transport Aeroplane, and Small Aeroplane Seating Systems	CS-ETSO/11
ETSO-C132a	Geosynchronous Orbit Aeronautical Mobile Satellite Services Aircraft Earth Station Equipment	CS-ETSO/12
ETSO-C135a	Large Aeroplane Wheels, and Wheels and Brake Assemblies	CS-ETSO/6
ETSO-C139a	Aircraft Audio Systems and Equipment	CS-ETSO/11
ETSO-C141	Aircraft Fluorescent Lighting Ballast/Fixture Equipment	CS-ETSO/Initial Issue
ETSO-C142b	Non-Rechargeable Lithium Cells and Batteries	CS-ETSO/16
ETSO-C144a	Passive Airborne Global Navigation Satellite System (GNSS) Antenna	CS-ETSO/6
ETSO-C145e A1	Airborne Navigation Sensors Using the Global Positioning System Augmented by the Satellite-Based Augmentation System	CS-ETSO/16
ETSO-C146e A1	Stand-Alone Airborne Navigation Equipment Using the Global Positioning System Augmented by the Satellite-Based Augmentation System	CS-ETSO/16
ETSO-C147a	Traffic Advisory System (TAS) Airborne Equipment	CS-ETSO/12
ETSO-C151d	Terrain Awareness and Warning System (TAWS)	CS-ETSO/16
ETSO-C153a	Integrated Modular Avionics (IMA) Platform and Modules	CS-ETSO/16
ETSO-C154c	Universal Access Transceiver (UAT) Automatic Dependent Surveillance-Broadcast (ADS-B) Equipment	CS-ETSO/7
ETSO-C155b	Recorder Independent Power Supply	CS-ETSO/13
ETSO-C157b	Flight Information Services-Broadcast (FIS-B) Equipment	CS-ETSO/12

EASA ETSO ref.	Title	Last amended by
ETSO-C158	Aeronautical Mobile High Frequency Data Link (HFDL) Equipment	CS-ETSO/7
ETSO-C159d	Next Generation Satellite Systems (NGSS) Equipment	CS-ETSO/16
ETSO-C160a A1	VDL Mode 2 Communications Equipment	CS-ETSO/16
ETSO-C161a	Ground-Based Augmentation System Positioning and Navigation Equipment	CS-ETSO/7
ETSO-C162a	Ground-Based Augmentation System Very High Frequency Data Broadcast Equipment	CS-ETSO/7
ETSO-C165b	Electronic Map Systems for Graphical Depiction of Aircraft Position	CS-ETSO/16
ETSO-C166b A3	Extended Squitter Automatic Dependent Surveillance-Broadcast (ADS-B) and Traffic Information Service-Broadcast (TIS-B) Equipment Operating on the Radio Frequency of 1090 Megahertz (MHz)	CS-ETSO/13
ETSO-C168	Aviation Visual Distress Signals	CS-ETSO/16
ETSO-C170	High-Frequency (HF) Radio Communication Transceiver Equipment Operating Within the Radio Frequency 1.5 to 30 Megahertz	CS-ETSO/7
ETSO-C172a	Cargo Restraint Strap Assemblies	CS-ETSO/12
ETSO-C173a	Nickel-Cadmium, Nickel Metal-Hydride, and Lead-Acid Batteries	CS-ETSO/11
ETSO-C174 A1	Battery-Based Emergency Power Unit (BEPU)	CS-ETSO/8
ETSO-C175	Galley Cart, Containers and Associated Components	CS-ETSO/3
ETSO-C178	Single Phase 115 VAC, 400 Hz Arc Fault Circuit Breakers	CS-ETSO/8
ETSO-C179b	Rechargeable Lithium Cells, Batteries, and Battery Systems	CS-ETSO/16
ETSO-C184	Galley Equipment	CS-ETSO/7
ETSO-C190	Active Airborne Global Navigation Satellite System (GNSS) Antenna	CS-ETSO/6
ETSO-C194	Helicopter Terrain Awareness and Warning System (HTAWS)	CS-ETSO/7
ETSO-C195b	Avionics Supporting Automatic Dependent Surveillance-Broadcast (ADS-B) Aircraft Surveillance	CS-ETSO/12
ETSO-C196b	Airborne Supplemental Navigation Sensors for Global Positioning System Equipment Using Aircraft-Based Augmentation	CS-ETSO/16
ETSO-C198	Automatic Flight Guidance and Control System (AFGCS) Equipment	CS-ETSO/8

EASA ETSO ref.	Title	Last amended by
ETSO-C199 A1	Traffic Awareness Beacon System (TABS)	CS-ETSO/16
ETSO-C200a	Low-Frequency Underwater Locating Device (ULD)	CS-ETSO/12
ETSO-C201	Attitude and Heading Reference Systems (AHRS)	CS-ETSO/11
ETSO-C202	Cargo Stopper Devices	CS-ETSO/11
ETSO-C203 A1	Fire containment covers (FCC)	CS-ETSO/13
ETSO-C207a	Aeronautical Mobile Airport Communication System (AeroMACS)	CS-ETSO/16
ETSO-C209	Electronic Flight Instrument System (EFIS) Display	CS-ETSO/13
ETSO-C210	Airborne Head-Up Display	CS-ETSO/13
ETSO-C214 A1	Functional ETSO equipment using an ETSO-C153a-authorized IMA platform or module	CS-ETSO/16

Index 2

EASA ETSO ref.	Title	Last amended by
ETSO-2C11e	Power Plant Fire Detection Instruments (Thermal and Flame Contact Types)	CS-ETSO/Initial Issue
ETSO-2C19c A1	Portable Water-Solution Type Hand Fire Extinguishers	CS-ETSO/16
ETSO-2C34f	ILS Glide Slope Receiving Equipment Operating within the Radio Frequency Range of 328.6–335.4 Megahertz (MHz)	CS-ETSO/Initial Issue
ETSO-2C35d	Radar Marker Receiving Equipment	CS-ETSO/Initial Issue
ETSO-2C36f	Airborne ILS Localizer Receiving Equipment Operating within the Radio Frequency Range 108–112 Megahertz	CS-ETSO/Initial Issue
ETSO-2C40c	VOR Receiving Equipment Operating within the Radio Frequency Range of 108–117.95 Megahertz	CS-ETSO/Initial Issue
ETSO-2C41d	Airborne Automatic Direction Finding (ADF) Equipment	CS-ETSO/Initial Issue
ETSO-2C48a	Carbon Monoxide Detector Instruments	CS-ETSO/6
ETSO-2C66b	Distance Measuring Equipment (DME) Operating within the Radio Frequency Range 960–1215 Megahertz	CS-ETSO/Initial Issue
ETSO-2C75	Hydraulic Hose Assembly	CS-ETSO/Initial Issue
ETSO-2C93b	Airborne Interim Standard Microwave Landing System Converter Equipment	CS-ETSO/Initial Issue
ETSO-2C104a	Microwave Landing System (MLS) Airborne Receiving Equipment	CS-ETSO/Initial Issue
ETSO-2C122	Devices That Prevent Blocked Channels Used in Two-Way Radio Communications Due to Simultaneous Transmissions	CS-ETSO/Initial Issue
ETSO-2C123c	Cockpit Voice Recorder Systems	CS-ETSO/16
ETSO-2C124c	Flight Data Recorder Systems	CS-ETSO/16
ETSO-2C128	Devices That Prevent Blocked Channels Used in Two-Way Radio Communications Due to Unintentional Transmissions	CS-ETSO/Initial Issue
ETSO-2C169a	VHF Radio Communications Transceiver Equipment Operating within the Radio Frequency Range 117.975 to 137 Megahertz	CS-ETSO/6
ETSO-2C176a	Aircraft Cockpit Image Recorder Systems	CS-ETSO/16
ETSO-2C177a	Data Link Recorder Equipment	CS-ETSO/16
ETSO-2C197 A1	Information Collection and Monitoring Systems	CS-ETSO/16

EASA ETSO ref.	Title	Last amended by
ETSO-2C204a	Circuit Card Assembly (CCA) Functional Sensors Using the Satellite-Based Augmentation System (SBAS) for Navigation and Non-Navigation Position/Velocity/Time (PVT) Output	CS-ETSO/16
ETSO-2C205a	Circuit Card Assembly (CCA) Functional Class Delta Equipment Using the Satellite-Based Augmentation System (SBAS) for Navigation Applications	CS-ETSO/16
ETSO-2C206	Circuit Card Assembly (CCA) Functional Sensors Using Aircraft-Based Augmentation for Navigation and Non-Navigation Position/Velocity/Time (PVT) Output	CS-ETSO/16
ETSO-2C500a	Combined ILS/MLS Airborne Receiving Equipment	CS-ETSO/Initial Issue
ETSO-2C501	Mode S Aircraft Data Link Processor	CS-ETSO/Initial Issue
ETSO-2C502	Helicopter Crew and Passenger Integrated Immersion Suits	CS-ETSO/1
ETSO-2C503	Helicopter Crew and Passenger Immersion Suits for Operations to or from Helidecks Located in a Hostile Sea Area	CS-ETSO/1
ETSO-2C504	Helicopter Constant-Wear Life Jackets for Operations to or from Helidecks Located in a Hostile Sea Area	CS-ETSO/1
ETSO-2C505	Helicopter Life Rafts for Operations to or from Helidecks Located in a Hostile Sea Area	CS-ETSO/1
ETSO-2C509	Light Aviation Secondary Surveillance Transponders (LAST)	CS-ETSO/2
ETSO-2C512	Portable Gaseous Oxygen Supply (PGOS)	CS-ETSO/3
ETSO-2C513	Tow Release	CS-ETSO/3
ETSO-2C514a	Airborne Systems for Non-Required Telecommunication Services (in Non-Aeronautical Frequency Bands) (ASNRT)	CS-ETSO/13
ETSO-2C515 A1	Aircraft Halocarbon Clean Agent Hand-Held Fire Extinguishers	CS-ETSO/16
ETSO-2C516	Reserved	N/A
ETSO-2C517	Automatic Deployable Flight Recorder (ADFR) Systems for Large Aeroplanes	CS-ETSO/16
ETSO-2C518	Runway Overrun Awareness and Alerting Systems	CS-ETSO/16
ETSO-2C519	Emergency Breathing Systems (EBSs)	CS-ETSO/16

- [Amdt ETSO/1]
- [Amdt ETSO/2]
- [Amdt ETSO/3]
- [Amdt ETSO/4]
- [Amdt ETSO/5]
- [Amdt ETSO/6]

[Amdt ETSO/7]
[Amdt ETSO/8]
[Amdt ETSO/9]
[Amdt ETSO/10]
[Amdt ETSO/11]
[Amdt ETSO/12]
[Amdt ETSO/13]
[Amdt ETSO/14]
[Amdt ETSO/16]

INDEX 1

ETSO-C10c

ED Decision 2020/011/R (applicable from 25.7.2020)

PRESSURE ALTIMETER SYSTEM

1 Applicability

This ETSO provides the requirements which pressure altimeter systems that are designed and manufactured on or after the date of this ETSO must meet in order to be identified with the applicable ETSO marking.

2 Procedures

2.1 General

The applicable procedures are detailed in CS-ETSO, [Subpart A](#).

2.2 Specific

None.

3 Technical Conditions

3.1 Basic

3.1.1 Minimum Performance Standard

The applicable standards are those provided in SAE International's Aerospace Standard AS8009C, Pressure Altimeter Systems, dated 24 May 2016, as amended by Appendix 1 to this ETSO.

3.1.2 Environmental Standard

See CS-ETSO, Subpart A, paragraph 2.1.

3.1.3 Software

See CS-ETSO, Subpart A, paragraph 2.2.

3.1.4 Airborne Electronic Hardware

See CS-ETSO, Subpart A, paragraph 2.3.

3.2 Specific

The declaration of design and performance (DDP) and the installation manual shall state the maximum calibrated altitude.

3.2.1 Failure Condition Classification

See CS-ETSO, Subpart A, paragraph 2.4.

4 Marking

4.1 General

See CS-ETSO, [Subpart A](#), Paragraph 1.2.

4.2 Specific

None.

5 Availability of Referenced Documents

See CS-ETSO, [Subpart A](#), paragraph 3.

[Amdt ETSO/16]

Appendix 1 to ETSO-C10c – Minimum Performance Standard (MPS) for Pressure Altimeter Systems

ED Decision 2020/011/R

This Appendix defines the modifications and additions to the MPS for pressure altimeter equipment specified in SAE AS8009C, Pressure Altimeter Systems, dated 24 May 2016.

SAE AS8009C Section(s)	Change
3.4	<p>Add a note following the paragraph to read:</p> <p>Note: Markings for the altitude range may be omitted for instruments that use a tape-type display.</p>
3.10	<p>Delete current Section 3.10 and Table 9. Replace with the following:</p> <p>3.10 Temperature Corrections</p> <p>Altimeters covered by this standard shall not incorporate automatic temperature corrections.</p>
3.11	<p>Add a new third paragraph to read:</p> <p>Instruments that use a tape-type display or present altitude with a digital readout are permitted to use tic marks every 100 feet with a more prominent mark every 500 feet in agreement with SAE ARP4102/7, Appendix A, Symbols 39 and/or 40.</p>
3.12	<p>Change the third sentence to read:</p> <p>The word ALTITUDE or ALT may be marked on the dial in capital letters and may be in the same finish as the numerals.</p>
3.12	<p>Add a note following the paragraph to read:</p> <p>Note: Markings for the altitude range may be omitted for instruments that use a tape-type display.</p>
5.	<p>Add a new paragraph:</p> <p>Some of these tests may be performed only once provided that it is demonstrated that this test will demonstrate performance for each article.</p>
5.10	<p>Add a new paragraph:</p> <p>For altimeters with an electronic display, this test may be replaced by showing compliance with SAE AS8034C, Section 3.8, Malfunctions/Failure Indications and Section 4.6, Operating Time.</p>
5.11	<p>Add a requirement for performance testing of Electronic Display Altimeters:</p> <p>Electronic displays shall demonstrate their compliance with the SAE AS8034C requirements specified in Table 10 using the test procedures specified in SAE AS8034C, Section 6, as applicable.</p>
6.29	<p>Add a requirement for environmental testing of Electronic Display Altimeters:</p>

	Electronic displays shall demonstrate the compliance of their equipment with the requirements of SAE AS8034B specified in Table 10 using the environmental performance requirements specified in SAE AS8034B, Section 5.
--	--

[Amdt ETSO/16]

ETSO-C13g

ED Decision 2020/011/R (applicable from 25.7.2020)

LIFE PRESERVERS**1 Applicability**

This ETSO provides the requirements which life preservers that are designed and manufactured on or after the date of this ETSO, must meet in order to be identified with the applicable ETSO marking.

2 Procedures

2.1 General

The applicable procedures are detailed in CS-ETSO, [Subpart A](#).

2.2 Specific

None.

3 Technical Conditions

3.1 Basic

The standards of this ETSO apply to items of equipment that are intended to function as life preservers.

3.1.1 Minimum Performance Standard

The applicable standards are those provided in SAE International's Aerospace Standard AS1354, Individual Inflatable Life Preserver, dated 24 February 2016, as amended by [Appendix 1](#).

3.1.1.1 Functional Qualification

The required functional performance under the test conditions specified in AS1354, Individual Inflatable Life Preserver, dated 24 February 2016, as amended by Appendix 1 and Appendix 2, shall be demonstrated.

3.1.2 Environmental Standard

The required performance under the test conditions specified in AS1354, Individual Inflatable Life Preserver, dated 24 February 2016, as amended by Appendix 1, shall be demonstrated.

3.1.3 Software

See CS-ETSO, Subpart A, paragraph 2.2.

3.1.4 Airborne Electronic Hardware

See CS-ETSO, Subpart A, paragraph 2.3.

3.2 Specific

3.2.1 Failure Condition Classification

Not applicable.

4 Marking

4.1 General

See CS-ETSO, [Subpart A](#), paragraph 1.2.

4.2 Specific

See [Appendix 1](#).

5 Availability of Referenced Documents

See CS-ETSO, [Subpart A](#), paragraph 3.

[Amdt ETSO/16]

Appendix 1 to ETSO-C13g – Functional and Environmental Qualification Requirements

ED Decision 2020/011/R

Appendix 1 modifies the text in SAE International’s Aerospace Standard AS1354, Individual Inflatable Life Preserver, dated 24 February 2016. Compliance with the modified text is required in order to comply with the requirements of this ETSO.

When reading AS1354	Do the following:
Section 1	Disregard
Section 2	Apply all the subsections unless they are disregarded or modified below:
	<p>Page 4, replace Subsection 2.1 with the following text:</p> <p>2.1 Applicable Documents</p> <p>The following publications form a part of this document to the extent specified herein. The applicable issue of cited publications shall be the issue that was in effect on the date of the publication of this document, unless otherwise specified. In the event of conflict between the text of this document and the references cited herein, the text of this document takes precedence. Nothing in this document, however, supersedes the applicable laws and regulations unless a specific exemption has been obtained.</p>
	<p>Page 6, Subsection 2.3 applies as written, except replace the definitions of the following terms with the ones below:</p> <p>APPROVED: The status of equipment that meets EASA standards.</p> <p>CHILLED HANDS TEST METHOD: A technique to simulate the reduced dexterity of chilled, wet hands that may occur during an emergency in a cold and wet environment. A naïve test subject simultaneously submerges their left and right forearms and hands in 50 °F (10 °C) water for 2 minutes and immediately upon removal attempts to open/operate the designated packaging/equipment. The test subject <i>shall</i> be healthy and wear a loose-fitting, sleeveless upper garment that will not inhibit blood flow to the arms and hands. (Alternate: GLOVED HANDS TEST METHOD)</p> <p>SEAT PITCH: The distance from any point on one seat to exactly the same point on the seat in front or behind it.</p> <p>TEST SUBJECTS: Individuals who participate in life preserver tests (e.g. donning, retention, flotation). All such individuals shall be naïve, i.e. they shall have had no experience in using a life preserver or the specific equipment to be tested, and they shall not have viewed or talked with other persons performing the same or similar activities. Note that individuals who have experience in using marine or boating life preservers are considered to be acceptable test subjects.</p>

Section 3	Apply all the subsections unless they are disregarded or modified below:
	<p>Page 7, Section 3, replace the introductory text with the following:</p> <p>3. DESIGN AND PERFORMANCE REQUIREMENTS</p> <p>Tests and measurements performed to demonstrate compliance with this standard shall be conducted with equipment that is calibrated according to the original equipment manufacturer (OEM) specifications, using standards and references that are traceable to a recognised national authority (e.g. the National Institute of Standards and Technology (NIST)). The description of the test results shall include the accuracy and precision of the measurement(s), e.g. measured in 5-pound increments with an accuracy of ± 0.10 pounds.</p> <p>All tests that require timing shall use time-encoded video. In addition, tests that require human subjects or a child test dummy shall use time-encoded video.</p> <p>Demonstration life preservers are not addressed by this ETSO. They are not intended to be functional and should be marked accordingly.</p>
	<p>Page 10, replace Subsection 3.9 with the following text:</p> <p>3.9 Donning</p> <p>Donning tests shall be performed to show compliance with the design requirements and the comprehensibility of markings. The procedure for donning the life preserver shall be simple and obvious such that it can be rapidly donned by an untrained person without any assistance. This shall be demonstrated in accordance with the test criteria and procedures in Subsection 5.3.</p> <p>For the adult and adult-child category, it shall be demonstrated that at least 75 % of the total number of test subjects, and at least 60 % of the test subjects in each age group specified in Subsection 5.3.1, can don the life preserver within 25 seconds, unassisted, starting with the packaged life preserver on the test participant's lap. It must also be demonstrated that an unassisted adult can install an appropriate life preserver on another adult or child within 30 seconds.</p> <p>For the child and infant-small child category, it shall be demonstrated that at least 60 % of five adult test subjects of both sexes between the ages of 20 and 40, unassisted, can install a child life preserver on a child who weighs between 35 and 90 pounds (15.88 and 40.82 kg) and an infant-small child life preserver on a child dummy within 90 seconds, unassisted, starting with the packaged life preserver.</p> <p>The donning-time test does not apply to constant wear life preservers that are intended to be fully donned by the wearer while on board the aircraft. The donning-time test does apply to constant wear life preservers that are intended to be partially donned by the wearer while on board the aircraft and require an additional donning procedure prior to inflating the life preserver or entering the water. For these partially donned life preserver designs, the test shall begin with the life preserver in the partially donned condition.</p>
	<p>Page 10, replace Subsection 3.10 with the following text:</p> <p>3.10 Retention</p> <p>The means of retaining the life preserver on the wearer for an adult, adult-child, and child life preserver shall require the wearer to secure no more than one attachment</p>

	<p>and make only one adjustment for fit. This requirement does not apply to constant wear life preservers. The retention means shall not make use of knots. The means of retaining the life preserver shall not require any action to secure it other than fastening and fit adjustment (e.g. removal of rubber bands, unfastening of attachment points). Partially donned life preservers shall not require the wearer to secure more than one attachment or make more than one adjustment for fit after the life preserver is partially donned.</p> <p>The means of retaining the life preserver shall be shown to be operable within 5 seconds with chilled or gloved hands (e.g. fastening/unfastening buckles, snapping/unsnapping, etc.). This will be demonstrated in accordance with the Chilled Hands or Gloved Hands Test Methods in Subsection 5.4.2. This requirement does not apply to constant wear life preservers that are intended to be fully donned by the wearer while on board the aircraft.</p> <p>The adult, adult-child, and child category life preserver shall remain inflated, secured, and not cause injury to a wearer when it is tested in accordance with 5.4. There shall be no damage to the life preserver as a result of the jump. Chafing of the wearer’s skin shall not be considered to be an injury.</p> <p>The infant-small child category life preserver shall remain inflated and undamaged, and the infant-small child dummy, specified in 5.3.2, shall remain properly secured in the donned life preserver, while being held by an adult and tested in accordance with 5.4.3.</p>
	<p>Page 11, replace Subsection 3.11.2 with the following text:</p> <p>3.11.2 Infant-Small Child</p> <p>The life preserver <i>shall</i> provide insulation for the wearer’s head and upper torso (i.e. from the waist up) with a minimum R-value of 0.25 (equivalent to approximately 2 mm of wetsuit fabric). There shall be a means, other than knots, to restrict the position of the life preserver relative to the wearer, so as to provide proper function and prevent the wearer from releasing the means of restriction. Means shall be provided to prevent the introduction and/or entrapment of water. This shall be demonstrated in accordance with the Flotation Attitude Test procedure in 5.5.2.</p>
	<p>Page 11, replace Subsection 3.13 with the following text:</p> <p>3.13 Tether, Infant-Small Child Category</p> <p>A tether of PIA-C-5040, Type 3 cord or equivalent, at least 72 inches (182.88 mm) long, shall be attached to the infant-small child life preserver. The attachment shall be located such that the flotation attitude specified in 3.11.2 is maintained when the line is held taut in the water. The attachment shall be shown to withstand a 70-pound (31.75 kg) pull for at least 3 seconds without a failure of the line or the attachment.</p> <p>A positive-buoyancy attachment means shall be provided at the free end of the tether. The attachment means shall be shown to be operable with cold, wet hands, using either the Chilled Hands or Gloved Hands Test Method. <i>This must be demonstrated in accordance with Subsection 5.9.</i> There shall be a provision for stowing or securing the tether during use so that it remains readily accessible and does not dangle loosely.</p>

	<p>Page 11, replace Subsection 3.14 with the following text:</p> <p>3.14 Survivor Locator Light</p> <p>The life preserver shall be equipped with a survivor locator light that meets the requirements of ETSO-C85b or TSO-C85b, Survivor Locator Lights. The light shall automatically activate upon initial immersion in the water or by other means that do not require additional action by the wearer once the life preserver is fully donned. The light shall be located so to enhance visibility from a surface vessel or from an aircraft.</p>
	<p>Page 12, replace Subsection 3.17.2 with the following text:</p> <p>3.17.2 Package Opening</p> <p>Opening of the package shall be demonstrated in accordance with the Package Opening test procedures in 5.7.</p>
	<p>Page 12, replace Subsection 3.18.1 with the following text:</p> <p>3.18.1 Instructions</p> <p>The proper donning procedure and other operational instructions shall be simple, obvious, and <i>shall</i> be presented pictorially with a minimum use of words. Instructions that pertain to operations normally accomplished after the life preserver has been donned shall be oriented so that the wearer, or the person assisting a child or an infant-small child wearer, can see them while in the water. Instructions shall be sized, positioned and contrasted with the background to make them easily readable and comprehensible at a viewing distance of 24 inches (60.96 cm) with illumination no greater than 0.05 ft-c (0.54 lux) by a person who has 20/20 vision. Written instructions shall use bold lettering at least 0.22 inches (5.6 mm) high with a stroke width of at least 0.047 inches (1.2 mm). Comprehensibility shall be demonstrated in accordance with the Comprehensibility test procedure in Subsection 5.8.</p>
Section 4	Apply all the subsections unless they are disregarded or modified below:
	<p>Page 13, replace Subsection 4.2.1 with the following text:</p> <p>4.2.1 Permeability</p> <p>The materials used in the construction of the air holding cell shall have a maximum permeability to helium of 5 L/m² in 24 hours at 77 °F (25 °C) when tested in accordance with 5.6.3.</p>
Section 5	Apply all the subsections unless they are disregarded or modified below:
	<p>Page 15, replace Subsection 5.1.2 with the following text:</p> <p>5.1.2 Overpressure</p> <p>The life preserver shall meet the minimum buoyancy requirements defined in 3.4 when it is subjected to overpressure. Inflate each flotation chamber via the oral inflation tube to 1 psig (6.89 kPa), then manually actuate the discharge of the gas reservoir for each chamber. Submerge the life preserver in fresh water at a temperature of 70 °F ± 5 °F (21.1 °C ± 2.8 °C), so that no part of it is less than 24 inches (60.96 cm) below the surface of the water. Measure the buoyancy to show compliance with the applicable requirement in Table 1. Keep the life preserver submerged for at least 8 hours, after which time it shall be shown to meet or exceed the requirement in Table 1.</p>

	<p>Alternatively, the test may be discontinued in less than 8 hours if buoyancy measurements taken at 4 successive 30-minute intervals show that the buoyant force of the life preserver has stabilised at or above the value specified in Table 1.</p>
	<p>Pages 15-16, replace Subsection 5.3.1 with the following text:</p> <p>5.3.1 Test Subjects</p> <p>At least 25 test subjects shall be employed in tests of an adult or adult-child preserver. At least 5 of those test subjects shall be from each of the following age groups: 20 to 29 years; 30 to 39 years; 40 to 49 years; 50 to 59 years; and 60 to 69 years. No more than 60 % of the test subjects in any age group may be of the same sex. The number of test subjects in any age group may not exceed 30 % of the total number of test subjects.</p> <p>Child-donning tests shall be performed by a minimum of 5 adult test subjects of both sexes between the ages of 20 and 40. Tests shall be performed using a child that weighs between 35 and 90 pounds (15.88 and 40.91 kg).</p> <p>Infant-small child donning tests shall be performed by a minimum of 5 adult test subjects of both sexes between the ages of 20 and 40. Tests shall be performed using an articulating infant-small child dummy per Subsection 5.3.2.</p> <p>Adult test subjects shall have no experience with inflatable life preservers or donning tests. Test subjects shall not be familiar with the manufacture, production, or maintenance of inflatable life preservers.</p> <p>Test subjects shall receive no donning instructions other than the general introduction briefing and preflight video briefing on the use of the life preserver per Appendix D — Donning Test Briefings. Instructions for the child and infant-small child category life preserver shall be the typical briefing given by a flight attendant to a parent/guardian that accompanies a child or infant on a flight. Test subjects may be informed (during the pre-test introduction briefing) that this is a timed test, and that their task is to don the life preserver within the applicable time frame specified in Subsection 3.9.</p> <p>Furthermore, the installation, operating and maintenance instructions shall also reflect the requirements of this section. The operating instructions must report the detailed content of the simulated preflight briefing and any special instructions for the unique aspects of operating the design of the life preserver that should be considered for its operational use and continued performance.</p>
	<p>Page 16, replace Subsection 5.3.3 with the following text:</p> <p>5.3.3 Arrangement</p> <p>Subjects in tests of an adult, adult-child, or child life preserver shall be seated in previously approved air carrier coach class seating, with a seat row in front of the test subjects, creating a seat pitch not exceeding 31 inches (78.74 cm). Subjects shall be seated one per row. All subjects shall have their seat belts fastened.</p> <p>Infant-small child life preserver donning tests shall be performed with the adult test subject holding the infant on their lap, seated between two other adult subjects who shall not assist or hamper the test subject who performs the donning test. The adult test subject shall be wearing their own life preserver.</p>

	<p>Page 16, replace Subsection 5.3.4 with the following text:</p> <p>5.3.4 Procedure</p> <p>The donning test shall start on signal with the packaged life preserver held on the test subject's lap, or for a constant wear life preserver, the test shall start in the partially donned configuration. The timing of the test shall end when the life preserver is properly donned, secured, and adjusted for fit (the means of adjustment shall be adjusted for a snug fit on the test subject). Donning tests shall be captured on video; the timing for each individual subject shall be recorded separately.</p>
	<p>Page 16, add two new subsections to 5.4 as follows:</p> <p>5.4.2 Retention Mechanism Test</p> <p>Demonstrate the operability of the life preserver retention mechanism using either the Chilled Hands or Gloved Hands Test Method (see 2.3 Definitions). At least 4 out of 5 test subjects shall secure the life preserver retention mechanism (e.g. fasten and then unfasten it) within 5 seconds. In cases for which additional participants are required, 75 % of the total number of test participants for each demonstration must complete the retention mechanism task within the allowed time.</p> <p>5.4.3 Infant-Small Child Life Preserver</p> <p>The infant-small child category life preserver shall remain inflated and undamaged, and the infant-small child dummy, specified in 5.3.2, shall remain properly secured in the donned life preserver, while being held by an adult who jumps into the water from a height of 5 feet (1.52 m) above the water. The adult shall wear an inflated life preserver for this test.</p>
	<p>Page 17, replace Subsection 5.6.2 with the following text:</p> <p>5.6.2 Flammability</p> <p>The life preserver and package shall be constructed of material that meets the requirements of the latest amendment of CS-25, Appendix F, Part I. The definition and use of parts that are considered to be small parts (e.g. oral inflation tubes, clips, etc.) that would not contribute significantly to the propagation of a fire must be coordinated in advance with EASA.</p>
	<p>Page 17, replace Subsection 5.6.3 with the following text:</p> <p>5.6.3 Permeability</p> <p>The permeability shall be tested in accordance with the permeability test procedure in FTMS 191, Method 5460; or alternatively, ASTM D1434-82, Procedure V may be used. The permeameter shall be calibrated for the gas that is used.</p>
	<p>Page 18, replace Subsection 5.7.1 with the following text:</p> <p>5.7.1 Pull Force</p> <p>The pull force necessary to operate the opening mechanism shall be mechanically demonstrated not to exceed 9 pounds (40 N), or the opening of the mechanism shall be demonstrated in less than 7 seconds by at least 8 of 10 females over the age of 60, without any preview of the instructions. The timing shall start when the test participant has both hands on the package and is ready to open it, and shall end when the package is fully opened (e.g. the pull tab/strip is completely removed). A nick or cut shall not be introduced in the edge of the material at the tear line unless it is</p>

	<p>normally a part of the package design. In cases for which additional participants are required, 75 % of the total number of test participants for each demonstration must complete the opening of the package within the allowed time.</p>
	<p>Page 18, replace Subsection 5.7.2 with the following text:</p> <p>5.7.2 Operation of the Opening Mechanism</p> <p>Operation of the opening mechanism shall be demonstrated within 10 seconds by 8 of 10 females with reduced dexterity simulated by the Chilled Hands or Gloved Hands Test Method, and without a preview of the instructions. The timing shall start when the test participant has both hands on the package and is ready to open it, and end when the life preserver is fully removed from the package. In cases for which additional participants are required, 75 % of the total number of test participants for each demonstration must complete the opening of the package within the allowed time.</p>
	<p>Page 18, replace Subsection 5.8 with the following text:</p> <p>5.8 Comprehensibility</p> <p>Comprehensibility shall be demonstrated by 5 out of 6 test subjects, tested independently, using an open-ended answer format (see examples in ANSI Z535 or ISO 9186:2001) and/or a successful empirical demonstration of the equipment or feature.</p>
	<p>Page 18, add new Subsection 5.9 as follows:</p> <p>5.9 Tether Attachment Test</p> <p>Demonstrate that the means of attachment, on the tether of the infant-small child life preserver, is operable using either the Chilled Hands or Gloved Hands Test Method (see 2.3 Definitions). At least 4 out of 5 test subjects shall secure the means of attachment of the life preserver. In cases for which additional participants are required, 75 % of the total number of test participants for each demonstration must complete the attachment task. This test may be performed on dry land.</p> <p>NOTE: The attachment should be demonstrated in the manner in which it is designed to be used; it should be attached to something as designed.</p>
Appendix A	No change
Appendix B	No change
Appendix C	<p>Page 24, replace Appendix C with Appendix 2 Tests Involving Subjects.</p> <p>See Appendix 2 on the final page.</p>
	<p>Page 25, add a new Appendix D as follows:</p> <p>Appendix D — Donning Test Briefings</p> <p>You must use the following scripts for the donning-test briefing. For the assisted donning tests, substitute the appropriate donning time requirement as specified in Subsection 3.9. The scripts may be modified as applicable for constant wear life preservers that are designed to be partially donned during flight.</p>

General introduction briefing script:

You are participating in a passenger safety study to determine how long it takes to put on an aircraft life preserver. You are seated in a seat that is similar to those found on passenger aeroplanes; please fasten your seatbelt [pause until all seatbelts are fastened].

The test will simulate an actual airline emergency; your goal is to put on the life preserver as quickly as possible within 25 seconds or less. Video cameras will record your actions.

To start the test, your instructor will say: '3, 2, 1, go!' This is your signal to open the package and put on the life preserver.

Following this introduction, a video of a simulated passenger information briefing will be presented. After the video, you will be handed your life preserver package.

[Optional: Before the video, please review the safety information card for additional instructions on putting on the life preserver.]

Preflight video briefing script:

This test will simulate an actual airline emergency; your goal is to put on the life preserver as quickly as possible within 25 seconds or less. To start the test, your instructor will say: '3, 2, 1, go!' This is your signal to open the package and put on the life preserver.

To put on your life preserver:

- Pull the tab and tear open the package.
- Remove the life preserver from the package.
- Pull the life preserver over your head.
- Grab the waist strap and wrap it around your waist.
- Insert the clip into the buckle and pull the end of the waist strap to tighten the belt.
- Raise your arms when you have finished.

[Amdt ETSO/16]

Appendix 2 to ETSO-C13g – Tests Involving Subjects*

ED Decision 2020/011/R

*NOTE: Tests that require human subjects or a child test dummy shall use time-encoded video.

Test name	Paragraph	Number of subjects
Donning Test	5.3	
<ul style="list-style-type: none"> • Adult or Adult-Child 	5.3.1	— 25 adults minimum — Age groups: 20-29, 30-39, 40-49, 50-59, 60-69 yrs (see 5.3.1 for more details)
<ul style="list-style-type: none"> • Child 	5.3.1	— 5 adults: ages: 20-40 years, male and female — 5 children: each child: 35-90 lbs (15.88-40.91 kg)
<ul style="list-style-type: none"> • Infant-Small Child 	5.3.1 5.3.2	— 5 adults: ages: 20-40 years, male and female — 1 anthropometric, infant-small child test dummy or child
Retention Test	5.4	
<ul style="list-style-type: none"> • Adult, Adult-Child, and Child 	5.4.1	— 3 adults minimum, including at least one 5th percentile female and one 95th percentile male (measured by weight and head circumference)
<ul style="list-style-type: none"> • Chilled Hands or Gloved Hands Test Method 	5.4.2	— 5 adults minimum (see 2.3)
<ul style="list-style-type: none"> • Infant-Small Child 	5.4.3	— 1 adult holding child test dummy or child (see 5.3.2)
Flotation Attitude Test	5.5	
<ul style="list-style-type: none"> • Adult, Adult-Child, or Child 	5.5.1	— 3 minimum, including at least one 5th percentile female and one 95th percentile male (measured by weight and head circumference)
Packaging Opening	5.7	
<ul style="list-style-type: none"> • Pull Force (2 methods) 	5.7.1	— Mechanical: not to exceed 9 lbs (40 N) OR — 10 minimum, female, older than 60 yrs

Test name	Paragraph	Number of subjects
<ul style="list-style-type: none">• Operation of the Opening Mechanism	5.7.2	—10 minimum, female with reduced dexterity simulated by chilled or gloved hands (see 2.3)
Comprehensibility	5.8	— 6 adults
Tether Attachment	5.9	— 5 adults minimum

[Amdt ETSO/1]

[Amdt ETSO/16]

ETSO-C20a

ED Decision 2020/011/R (applicable from 25.7.2020)

COMBUSTION HEATERS AND ACCESSORIES

1 Applicability

This ETSO provides the requirements which combustion heaters and accessories that are designed and manufactured on or after the date of this ETSO, must meet in order to be identified with the applicable ETSO marking.

2 Procedures

2.1 General

The applicable procedures are detailed in CS-ETSO [Subpart A](#).

2.2 Specific

None.

3 Technical Conditions

3.1 Basic

3.1.1 Minimum Performance Standard

The applicable standards are those provided in SAE International's Aerospace Standard AS8040B, Heater, Aircraft, Internal Combustion Heat Exchanger Type, dated 14 February 2013, as amended by Appendices 1 and 2 to this ETSO.

3.1.1.1 Functionality

This standard in this ETSO applies to equipment that is intended to provide heated air for civil aircraft.

Note: For combustion heaters and accessories, the maintenance and inspection items contained in the instructions for continued airworthiness play an important role in preventing failures that result in combustion by-products entering the cabin/flight deck.

3.1.2 Environmental Standard

The required performance under the test procedures in SAE AS8040B, Heater, Aircraft, Internal Combustion Heat Exchanger Type, dated 14 February 2013, as amended by Appendix 1 to this ETSO, using standard environmental conditions and test procedures that are appropriate for airborne equipment, shall be demonstrated.

3.1.3 Software

See CS-ETSO, Subpart A, paragraph 2.2.

3.1.4 Airborne Electronic Hardware

See CS-ETSO, Subpart A, paragraph 2.3.

3.2 Specific

3.2.1 Failure Condition Classification

(1) A failure of the function defined in paragraph 3.1.1.1 of this ETSO is a

major failure condition.

- (2) A loss of the function defined in paragraph 3.1.1.1 of this ETSO is a *minor* failure condition.
- (3) Design the system to at least fulfil these failure conditions above.

4 Marking

4.1 General

See CS-ETSO, [Subpart A](#), paragraph 1.2.

4.2 Specific

If the article includes software and/or airborne electronic hardware, then the part numbering scheme for the article must identify the configuration of both the software and the airborne electronic hardware. The part numbering scheme can use separate, unique part numbers for the software, the hardware, and the airborne electronic hardware.

If the combustion heater includes a deviation from this ETSO, the marking must include a means to indicate that a deviation was granted.

5 Availability of Referenced Document

See CS-ETSO, [Subpart A](#), paragraph 3.

[Amdt ETSO/16]

Appendix 1 to ETSO-C20a – MPS for Combustion Heater Based on SAE AS8040B

ED Decision 2020/011/R

This Appendix prescribes the MPS for combustion heaters. The applicable standard is SAE International's Aerospace Standard AS8040B, Heater, Aircraft, Internal Combustion Heat Exchanger Type, dated 14 February 2013. EASA has modified it as follows:

Section: 3. Accessories

3.2.a. Includes the fuel/air ratio controller, fuel lines and preheater.

3.2.b. Rewritten to read 'Ignition System: The ignition system uses an aircraft-supplied energy source to enable the proper functioning of the igniter. Examples of accessory devices that may be utilised in a heater ignition system include but are not limited to:'

3.2.b.2. Replaces the term 'spark plug' with 'igniter'.

3.2.b.3. Removes the statement 'Heaters with output ratings of 11,700 W (40,000 Btu/hour) or less may use an electrically heated resistance wire as an ignition source.'

3.2.c. Includes the requirement 'Any component whose failure could lead to an unsafe condition, such as ducting, that is in a fire zone, must be fireproof.'

3.2.c. Includes ducting/tubing, the combustion air blower, combustion air flow sensor, ventilation air flow sensor, and air flow/pressure regulator.

3.2.d.1. Revised to read 'Cabin temperature controls'.

3.2.e. Includes a device to sense differential pressure across the combustion chamber, a device to sense combustion, a device that senses excessive combustion by-products in the ventilation air, a device to shut off the fuel flow when required, and a device to alert the crew that a safety system has engaged.

3.3.2. Includes the phrase 'having the capacity to withstand at least as well as .015-inch-thick stainless steel, the heat produced when there is a severe fire of extended duration.'

3.5. Includes the service ceiling.

3.6. Includes the statement 'It is best practice to set inspection, maintenance and/or replacement intervals based on individual component performance during design qualification testing (such as endurance testing).'

Section: 4. Detailed Requirements

4.3.1. Replaces 'gasoline or aviation grade kerosene, or both' with 'fuel'.

4.3.4. Adds 'fittings and controls' after 'All fuel lines'.

4.3.5. Replaces 'no lead or low lead type gasoline and kerosene' with the word 'applicable'. Adds 'Low starting temperature limits for other types of fuels need to be addressed on a case-by-case basis.' to the end of this paragraph.

4.5. Replaces '649 °C (1 200 °F)' with 'material capabilities in this section of the heater'. Adds the sentences 'Best practice is to ensure that the temperature at the point of discharge does not exceed

649 °C (1 200 °F). Consideration should also be given to the impact of heat impingement on the region of the aircraft that surrounds the combustion heater.’ at the end of the paragraph.

4.6.3. Adds at the end of the paragraph the following: ‘or heated solid surface, though it is not considered to be a best practice to use resistance wires as ignition sources for power levels above 11 700 W.’

4.6.8. Adds the statement ‘Other types of fuels need to be addressed on a case-by-case basis.’ at the end of the paragraph.

4.6.9. Adds the statement ‘Other types of fuels need to be addressed on a case-by-case basis.’ at the end of the paragraph.

4.7.d. replaced with this paragraph: ‘These safety controls shall be independent of the controls that are normally used to control the operation of the heater. The shut-off of ignition and fuel shall occur at a point that is remote from the heater itself. The combustion heater shall have a means to warn the crew when any heater whose heat output is essential for safe operation has been shut off by the automatic means. The requirement to shut off ignition and fuel at a point that is remote from the heater until restarted by the crew, may require a safety interlock relay and an additional fuel shut-off device to be supplied in addition to the valve that is usually supplied with the heater as an accessory. The relay and valve are the responsibility of the installer. See 5.2.10.6 for the tests to be conducted on safety controls.’

4.9. Adds at the end of the first paragraph: ‘Use electrical load analysis to show that the heater is safe to operate in the worst-case situation.’

4.12. Adds a new paragraph:

Radio Interference

4.12.1 If the manufacturer elects to demonstrate compliance with the standard radio interference requirements, it is considered to be a best practice to test the combustion heat exchanger per:

- (a) EUROCAE/RTCA, ‘Environmental conditions and test procedures for airborne equipment’, ED-14D/DO-160D Change 3 (or later revisions), Section 21, Category M, for operation in the passenger compartment and the flight crew compartment; and
- (b) EUROCAE ED-14D/RTCA document DO-160D Change 3 (or later revisions), Section 21, Category H, for operation in areas not accessible during the flight, and report the result in the aircraft flight manual supplement.

4.12.2 If the manufacturer elects not to demonstrate compliance with the radio interference requirements, the manufacturer shall include the following statement in the aircraft flight manual supplement for the combustion heat exchanger:

‘This combustion heat exchanger assembly does not include protection against radio and/or avionics interference, and has not been tested against it.’

Section: 5 Required Testing

The initial paragraph includes the statement ‘Test plans and reports shall be generated and retained for the life of the design.’

5.2.2.2. Revised to include ‘A suitable instrument with a resolution of 5 ppm or better, calibrated against a known standard, will be used to determine CO concentration.’

5.2.2.3. Adds the statement ‘A pressure decay test may alternatively be used, provided that the decay rate can be determined to be equivalent to the requirements listed above.’ at the end of the paragraph.

5.2.3. Replaces:

‘The service ceiling determined by this test shall meet the requirement specified by the purchaser.’

with:

‘It is typical for the service ceiling of a combustion heater to be at least 6 100 m (20 000 ft), and in order to ensure that there is an adequate margin with this test being performed on only one heater, a safety margin of 5 % shall be applied. Therefore, in order to set a service ceiling of 6 100 m (20 000 ft), the peak of the ignition characteristics curve shall be no lower than 6 405 m (21 000 ft).’

5.2.4. The text is replaced by the following:

‘Install the test unit into the test set-up used in 5.2.2.1 and cold soak the combustion heater assembly to - 54 °C (- 65 °F) for gasoline type heaters, and - 29 °C (- 20 °F) for kerosene type heaters (for other fuel types, the applicable temperature will be determined on a case-by-case basis). The valve leakage in the closed position with either the rated fuel pressure or the minimum practical fuel pressure shall not exceed 0.068 fluid ounces (2 mL) of fuel in 10 minutes. Supply combustion air and ventilating air to the heater at sea-level pressure and a temperature of - 54 °C (- 65 °F). The temperature of the fuel supplied to the heater shall be - 54 °C (- 65 °F) for gasoline-type heaters and - 29 °C (- 20 °F) for kerosene-type heaters. The combustion and ventilating air pressure levels and the mass flow rates shall be the same as in 5.2.2.1. Glow plug ignited heaters shall ignite within 200 seconds. Spark ignited heaters shall ignite within 15 seconds when burning gasoline-type fuels, and within 60 seconds when burning kerosene-type fuels. Measure and record the parameters specified in 5.2.2.1.’

5.2.10.6.2.1. This includes the following statement after the first sentence in the second paragraph: ‘Leakage through the fuel valve shall then be measured, and shall not exceed 0.068 fluid ounces (2 mL) in 10 minutes.’

Section: 6 Desirable Features

6.1.2 This includes the statement ‘Other types of fuels need to be addressed on a case-by-case basis.’

[Amdt ETSO/16]

Appendix 2 to ETSO-C20a – Instructions for Continued Airworthiness of the Aircraft Combustion Heater and Accessories

ED Decision 2020/011/R

- 1.0 The following information contained in this Appendix must be included in the manual to ensure that the combustion heater and its accessories continue to comply with the ETSO once it is installed in a product:
 - 1.1 Scheduling information for each part of the combustion heater, stating the inspection criteria and service limits. Necessary cross-references to the Airworthiness Limitations section must also be included.
 - 1.2 Troubleshooting information that describes the probable malfunctions, and how to recognise and resolve those malfunctions.
 - 1.3 Information that describes the order and method for removing and replacing parts, the order and method for disassembly and assembly, with any necessary precautions to be taken.
 - 1.4 Cleaning and inspection instructions that cover the material and apparatus to be used and the methods and precautions to be taken. Methods of inspection must also be included.
 - 1.5 Details of repair methods for worn or otherwise substandard parts and components, along with the information necessary to determine when a replacement is necessary.
 - 1.6 Instructions for testing, including the use of the test equipment and instrumentation.
 - 1.7 A list of the tools and equipment that are necessary for maintenance, and guidance for their use.
 - 1.8 Instructions on how to ensure that the combustion heater assembly is fit to return to service after maintenance and prior to installation (for example, procedures for a pressure decay test).

[Amdt ETSO/16]

ETSO-C27a

ED Decision 2020/011/R (applicable from 25.7.2020)

TWIN SEAPLANE FLOATS**1 Applicability**

This ETSO provides the requirements which twin seaplanes floats that are designed and manufactured on or after the date of this ETSO must meet in order to be identified with the applicable ETSO marking.

2 Procedures**2.1 General**

The applicable procedures are detailed in CS-ETSO, [Subpart A](#).

2.2 Specific

None.

3 Technical conditions**3.1 Basic****3.1.1 Minimum Performance Standard**

The applicable standards are those provided in Aerospace Industries of America, Inc., National Aerospace Standard (NAS) 807, Revision 2, Twin Seaplane Floats, dated 30 June 2017.

3.1.2 Environmental Standard

See CS-ETSO, Subpart A, paragraph 2.1.

3.1.3 Software

See CS-ETSO, Subpart A, paragraph 2.2.

3.1.4 Airborne Electronic Hardware

See CS-ETSO, Subpart A, paragraph 2.3.

3.2 Specific**3.2.1 Functionality**

The standards of this ETSO apply to twin seaplane floats that are suitable for use on aeroplanes.

3.2.2 Failure Condition Classification

A failure condition classification is not required.

3.2.3 Functional Qualification

The materials and workmanship must conform to the requirements specified in Section 3 of NAS 807, Revision 2. The functional performance must be demonstrated under the test conditions specified in Section 4 of NAS 807, Revision 2. The applicant must define the design parameters to which the article is qualified (e.g. maximum aeroplane weight, V_{so} , etc.).

4 Marking

4.1 General

See CS-ETSO, [Subpart A](#), paragraph 1.2.

4.2 Specific

None.

5 Availability of Referenced Documents

See CS-ETSO, [Subpart A](#), paragraph 3.

[Amdt ETSO/16]

ETSO-C43d

ED Decision 2020/011/R (applicable from 25.7.2020)

TEMPERATURE INSTRUMENTS**1 Applicability**

This ETSO provides the requirements which new models of temperature instruments that are designed and manufactured on or after the date of this ETSO must meet in order to be identified with the applicable ETSO marking.

2 Procedures

2.1 General

The applicable procedures are detailed in CS-ETSO, [Subpart A](#).

2.2 Specific

None.

3 Technical Conditions

3.1 Basic

3.1.1 Minimum Performance Standard

The applicable standards are those provided in SAE International's Aerospace Standard AS8005 'Minimum Performance Standard for Temperature Instruments' Revision A, September 1996, as amended by Appendix 1.

Exceptions:

- (i) In the friction error test SAE AS8005A, paragraph 4.8, the vibration (to minimise friction) provisions of paragraph 4.3 do not apply.
- (ii) For clarification, the vibration test of SAE AS8005A, paragraph 5.8, shall be conducted in accordance with the test procedure required by paragraph 3.1.2 below.

3.1.2 Environmental Standard

See CS-ETSO, [Subpart A](#), paragraph 2.1.

3.1.3 Software

See CS-ETSO, [Subpart A](#), paragraph 2.2.

3.1.4 Airborne Electronic Hardware

See CS-ETSO, [Subpart A](#), paragraph 2.3.

3.2 Specific

3.2.1 Failure Condition Classification

See CS-ETSO, [Subpart A](#), paragraph 2.4.

4 Marking

4.1 General

See CS-ETSO, [Subpart A](#), paragraph 1.2.

4.2 Specific

None.

5 Availability of Referenced Documents

See CS-ETSO, [Subpart A](#), paragraph 3.

[Amdt ETSO/16]

Appendix 1 to ETSO-C43d – Modifications to SAE AS8005A

ED Decision 2020/011/R

- Change Section 4.1 of SAE AS8005A to read:
'Unless otherwise specified herein, all the tests required shall be made at the atmospheric conditions specified in Section 3.5 of the document required by Section 3.1.2 of ETSO-C43d.'
- Remove Section 4.3 of SAE AS8005A, as vibration as a means to reduce friction is no longer acceptable.
- In Section 5 of SAE AS8005A, remove the sentence 'The order of tests shall be in accordance with paragraph 3.2, page 5, DO-138.'
- In Section 5 of SAE AS8005A, the text 'RTCA Document Number DO-138 entitled "Environmental Conditions and Test Proc. for Airborne Electronic/Electrical Equipment and Instruments", dated 27 June 1968' shall be replaced with the document required by Section 3.1.2 of ETSO-C43d.'
- In Section 5 of SAE AS8005A, any reference to 'DO-138' shall be replaced by a reference to the document required by Section 3.1.2 of ETSO-C43d'.

[Amdt ETSO/16]

ETSO-C113b

ED Decision 2020/011/R (applicable from 25.7.2020)

AIRBORNE MULTIPURPOSE ELECTRONIC DISPLAYS**1 Applicability**

This ETSO provides the requirements which Airborne Multipurpose Electronic Displays that are designed and manufactured on or after the date of this ETSO must meet in order to be identified with the applicable ETSO marking.

2 Procedures

2.1 General

The applicable procedures are detailed in CS-ETSO, [Subpart A](#).

2.2 Specific

None.

3 Technical Conditions

3.1 Basic

3.1.1 Minimum Performance Standard

The applicable standards are those provided in SAE AS8034C, Minimum Performance Standards for Airborne Multipurpose Electronic Displays, dated 30 July 2018, as modified by paragraph 3.1.1.1 of this ETSO. Additional requirements on colour can be found in [Appendix 1](#) to this document.

To be eligible to this ETSO standard, the equipment shall at least contain a display unit that provides the visualisation function.

It should be noted that this ETSO standard does not provide minimum performance standards for head-up displays or head-worn displays. ETSO-C210 provides requirements for head-up displays.

3.1.1.1 Modifications to AS8034C Section 5

SAE AS8034C, Section 5, second bullet, page 22, is modified as follows:

‘During the specified testing, ~~(5.5, 5.20)~~ it is up to the applicant to prove that the touchscreen functions as intended during the test and that no false positive touches are received. ~~Touch screen compliance may be demonstrated by testing during DO-160G, outside of the DO-160G testing, analysis or some combination thereof.~~ Software simulation cannot be used in lieu of physical activation.’

SAE AS8034C, Section 5.1, is amended as follows:

- Modify the text of Section 5.1 to replace ‘The following performance requirements (5.1.1 through 5.1.6)’ with ‘The following performance requirements (5.1.1 through 5.1.7)’.

- An additional section is added:

‘5.1.7 Touchscreen

The display system shall meet the touchscreen display

characteristics of the following paragraphs:

a. 4.7.1 Latency

b. 4.7.3 Touchscreen Selection Accuracy'

For SAE AS8034C, Section 5.4.4.3, Overpressure Test, the last sentence is amended as follows:

'When the equipment is subjected to the overpressure test, the requirements of 5.1 (excluding 5.1.7) shall be met.'

3.1.2 Environmental Standard

See CS-ETSO, [Subpart A](#), paragraph 2.1.

3.1.3 Software

See CS-ETSO, [Subpart A](#), paragraph 2.2.

3.1.4 Airborne Electronic Hardware

See CS-ETSO, [Subpart A](#), paragraph 2.3.

3.2 Specific

3.2.1 Failure Condition Classification

See CS-ETSO, [Subpart A](#), paragraph 2.4.

4 Marking

4.1 General

Marking as detailed in CS-ETSO, [Subpart A](#), paragraph 1.2.

4.2 Specific

None.

5 Availability of Referenced Documents

See CS-ETSO, [Subpart A](#), paragraph 3.

[Amdt ETSO/11]

[Amdt ETSO/16]

Appendix 1 to ETSO-C113b – Colour

ED Decision 2020/011/R

SAE AS8034C, Section 4.3.4, lays down colour-coding requirements. This Appendix provides additional guidance on colours.

1. Display features, precipitation, and turbulence areas should be colour-coded as depicted in Table A1 and Table A2 respectively, unless otherwise specified by the ETSO application being displayed.

Table A1

Display Feature	Colour
Warnings	Red
Flight envelope and system limits, non-normal sources	Red/Amber/Yellow/White as appropriate
Cautions	Amber/Yellow
Scales and associated figures	White ^{Note}
Earth	Tan/Brown
Sky	Cyan/Blue
Engaged Modes/normal conditions/safe operation	Green

Note: Use of the colour green for tape elements (for example, airspeed and altitude) has also been found to be acceptable if the colour green does not adversely affect flight crew alerting.

Table A2

Precipitation and Turbulence	Colour
Precipitation up to 4 millimetres per hour (mm/hour)	Green
Precipitation 4–12 mm/hour	Amber/Yellow
Precipitation 12–50 mm/hour	Red
Precipitation Above 50 mm/hour	Magenta
Turbulence	White or Magenta

2. Background colour (grey or other shade) may be used to enhance the display presentation. However, the colour selected should not impair the use of the overlaid information elements. Labels, display-based controls, menus, symbols, and graphics should all remain identifiable and distinguishable.
3. Colours should track the brightness so that the chrominance and the relative chrominance separation are maintained as much as possible during day-night operations.

[Amdt ETSO/11]

[Amdt ETSO/16]

ETSO-C117b*ED Decision 2020/011/R (applicable from 25.7.2020)***AIRBORNE WIND SHEAR WARNING AND ESCAPE GUIDANCE SYSTEMS (REACTIVE TYPE)
FOR TRANSPORT AEROPLANES****1 Applicability**

This ETSO provides the requirements that airborne wind shear warning and escape guidance systems (reactive type) for transport aeroplanes that are designed and manufactured on or after the date of this ETSO, must meet in order to be identified with the applicable ETSO marking. It is not applicable to systems that look ahead to sense wind shear conditions before the phenomenon is encountered, nor to systems that use atmospheric and/or other data to predict the likelihood of a wind shear alert.

Appendix 1 to this ETSO describes the MPS for the airborne wind shear warning and escape guidance systems for transport category aeroplanes.

Appendix 2 to this ETSO describes the wind field models used to evaluate the performance of a wind shear warning and escape guidance system.

Appendix 3 to this ETSO describes the conversion of the velocity equations in Appendix 2 to rectangular coordinates.

Appendix 4 to this ETSO contains data that defines the Dryden turbulence model and the discrete gust model used in conducting the required wind shear alert tests.

Appendix 5 to this ETSO describes shear intensity.

Appendix 6 to this ETSO provides a sample computer listing for a simplified aeroplane simulation model for evaluating the effectiveness of various guidance schemes.

2 Procedures**2.1 General**

The applicable procedures are detailed in CS-ETSO, [Subpart A](#).

2.2 Specific

None.

3 Technical Conditions**3.1- General****3.1.1 Minimum Performance Standard**

The applicable standards are provided in the attached Appendix 1.

3.1.2 Environmental Standard

See CS-ETSO, [Subpart A](#), paragraph 2.1

3.1.3 Computer Software

See CS-ETSO, [Subpart A](#), paragraph 2.2.

3.1.4 Airborne Electronic Hardware

See CS-ETSO, [Subpart A](#), paragraph 2.3.

3.2 Specific

3.2.1 Failure Condition Classification

See CS-ETSO, [Subpart A](#), paragraph 2.4.

A failure of the function defined in 3.1.1 above that results in an unannounced malfunction or a missed wind shear detection is a major failure condition.

A loss of the function defined in 3.1.1 above is a minor failure condition.

4 Marking

4.1 General

See CS-ETSO, [Subpart A](#), paragraph 1.2.

4.2 Specific

None.

5 Availability of Referenced Documents

See CS-ETSO, [Subpart A](#), paragraph 3.

[Amdt ETSO/16]

Appendix 1 to ETSO-C117b – EASA Performance Standard for Airborne Wind Shear Warning and Escape Guidance Systems for Transport Aeroplanes

ED Decision 2020/011/R

1. PURPOSE

This Appendix establishes the minimum performance standard (MPS) for airborne wind shear warning and escape guidance systems for transport category aeroplanes.

2. SCOPE

The scope of this Appendix is to provide MPS for airborne wind shear warning and escape guidance systems for transport category aeroplanes. All the paragraph references cited herein are in reference to this Appendix only.

This performance standard applies only to wind shear warning systems which identify wind shear phenomena by sensing an encounter with conditions that exceed the threshold values contained in this performance standard. In addition to wind shear warning criteria, this performance standard provides criteria that are applicable to systems that provide optional wind shear caution alert capabilities. Wind shear escape guidance is provided to assist the pilot in obtaining the desired flight path during such an encounter.

3. DEFINITION OF TERMS

a. Airborne wind shear warning system

A device or system which uses various sensor inputs to identify the presence of wind shear once the phenomenon is encountered, and provides the pilot with a timely warning. The system may include both wind shear warning and wind shear caution alerts. A warning device of this type does not provide escape guidance information to the pilot to satisfy the criteria for warning and flight guidance systems.

b. Airborne wind shear warning and escape guidance system

A device or system which uses various sensor inputs to identify the presence of wind shear once the phenomenon is encountered, and provides the pilot with a timely warning and adequate flight guidance to improve the probability of recovery from the wind shear encounter. This system may include both wind shear warning and wind shear caution alerts.

c. Airborne wind shear auto recovery system

A device or system which integrates or couples autopilot and/or autothrottle systems of the aeroplanes with an airborne wind shear flight guidance system.

d. Airborne wind shear escape guidance system

A system which provides the crew with flight guidance information to improve the probability of recovery once a wind shear phenomenon is encountered.

e. Failure

The inability of a system, subsystem, unit, or part to perform within the previously specified limits.

- f. False warning or caution
A warning or caution which occurs when the wind shear warning or caution threshold of the system is not exceeded.
- g. Nuisance warning or caution
A warning or caution which occurs when a phenomenon is encountered, such as turbulence, which does not, in fact, endanger the aeroplane because of the duration of the subsequent change in the magnitude of the wind shear.
- h. Recovery procedure
A vertical flight path control technique that is used to maximise the potential for a recovery from an inadvertent encounter with wind shear.
- i. Severe wind shear
A wind shear of sufficient intensity and duration that it exceeds the performance capability of a particular aeroplane type. This would be likely to cause an inadvertent loss of control or ground contact if the pilot did not have information available from an airborne wind shear warning and escape guidance system which meets the criteria of this ETSO.
- j. Wind shear caution alert
An alert that is triggered by increasing performance conditions, which is set at a wind shear level that requires immediate crew awareness and probably subsequent corrective action by the pilot.
- k. Wind shear warning alert
An alert that is triggered by decreasing performance conditions, which is set at a wind shear level that requires immediate corrective action by the pilot.

4. GENERAL REQUIREMENTS

In addition to the performance requirements provided in the main text of this Performance Standard and in the Appendices to ETSO-C117b, the following general requirements and equipment characteristics are defined below:

- a. General standards
The following general requirements shall be met by all wind shear warning and escape guidance systems:
 - (1) Airworthiness
The design and manufacture of the airborne equipment shall provide for installation so as not to impair the airworthiness of the aeroplane. The material shall be of a quality which experience and/or tests have demonstrated to be suitable and dependable for use in aeroplane systems. The workmanship shall be consistent with high-quality aeroplane electromechanical and electronic component manufacturing practices.
 - (2) General performance
The equipment shall perform its intended function, as defined by the manufacturer.

- (3) Fire resistance

Except for small parts (such as knobs, fasteners, seals, grommets and small electrical parts) that would not significantly contribute to the propagation of fire, all the materials that are used shall be self-extinguishing. One means to show compliance with this requirement is contained in Part 25, Appendix F.
- (4) Operation of controls

Controls that are intended for use during flight shall be designed to minimise errors, and when operated in any possible combinations and sequences, shall not result in a condition whose presence or continuation would be detrimental to the continued performance of the equipment.
- (5) Accessibility of controls

Controls that are not normally adjusted in flight shall not be readily accessible to the operator.
- (6) Interfaces

The interfaces with other aeroplane equipment shall be designed such that the normal or abnormal operation of the wind shear warning and escape guidance equipment does not adversely affect the operation of other equipment.
- (7) Compatibility of components

If a system component is individually acceptable but requires calibration adjustments or matching to other components in the aeroplane for its proper operation, it shall be identified in a manner that will ensure its performance to the requirements specified in this ETSO.
- (8) Interchangeability

System components which are identified with the same manufactured part number shall be completely interchangeable.
- (9) Control/display capability

A suitable interface shall be provided to allow data input, data output, and control of the operation of the equipment. The control/display shall be operable by one person with the use of only one hand.
- (10) Control/display readability

The equipment shall be designed so that all the displays and controls are readable under all cockpit ambient light conditions, ranging from total darkness to reflected sunlight, and are arranged to facilitate the use of the equipment. If limitations are necessary on equipment installations to ensure that the displays are readable, they shall be included in the installation instructions.
- (11) Effects of test procedures

The design of the equipment shall be such that the application of the specified test procedures does not produce a condition that is detrimental to the performance of the equipment, except as specifically allowed.
- (12) Equipment computational response time

The equipment shall employ suitable update rates for the computation and display of detection and guidance information.

(13) Supplemental heating or cooling

If supplemental heating or cooling is required by system components to ensure that the requirements of this ETSO are met, they shall be specified by the equipment manufacturer in the installation instructions.

(14) Self-test capability

The equipment shall employ a self-test capability to verify the proper operation of the system.

(i) Any manually initiated self-test mode of operation shall automatically return the system to the normal operating mode upon completion of a successful test.

(ii) Any automatically activated self-test feature shall annunciate this mode of operation to the pilot if this feature activates annunciation lights, aural messages, or displaces the guidance commands in any way.

(iii) Use of the system self-test feature shall not adversely affect the performance of operation of other aeroplane systems.

(iv) A failure of the system to successfully pass the self-test shall be annunciated.

(15) Independence of warning and escape guidance functions

Irrespective of whether the warning and escape guidance functions are in a combined system or are separate systems, they should be sufficiently independent such that a failure of either system does not necessarily preclude or inhibit the presentation of information from the other. A warning system failure shall not result in any ambiguous or erroneous guidance system mode annunciations.

(16) System reliability

(i) The probability of a false warning being generated within the wind shear warning system or the wind shear warning and escape guidance system shall be $1E-4$ or less per flight hour.

(ii) The probability of an unannunciated failure of the wind shear warning system or the wind shear warning and escape guidance system shall be $1E-5$ or less per flight hour (reserved).

b. Equipment functional requirements — standard conditions

The equipment shall meet the following functional requirements:

(1) Mode annunciation

The mode of operation of the wind shear escape guidance display shall be annunciated to the pilot upon activation of the escape guidance during a wind shear encounter, and upon reversion to a different flight guidance mode.

(2) Malfunction/failure indications

The equipment shall indicate:

(i) any inadequacy or absence of primary power;

(ii) equipment failures;

(iii) inadequate or invalid warning or guidance displays or output signals; and

(iv) inadequate or invalid sensor signals or sources.

These malfunction/failure indications shall occur independently of any operator actions. The lack of adequate warning displays, escape guidance information, or sensor signals or sources shall be annunciated when compliance with the requirements of this ETSO cannot be assured.

(3) Wind shear caution alert

If the equipment includes a wind shear caution:

- (i) it shall provide an annunciation of increasing performance shear (updraft, increasing headwind, or decreasing tailwind) in accordance with the shear intensity curve shown in Figure 1;
- (ii) this caution alert shall display or provide an appropriate output for display of an amber caution annunciation dedicated for this purpose. An aural alert may be provided as an option. The caution display (or output) should remain until the threshold wind shear condition no longer exists (not less than 3 seconds) or a wind shear warning alert occurs; and
- (iii) gust conditions shall not cause a nuisance caution alert. Turbulence shall not cause more than one nuisance caution alert per 250 hours (or 3 000 flight cycles based on 1 hour/flight cycle) of system operation.

(4) Wind shear warning alert

- (i) A wind shear warning alert shall provide an annunciation of decreasing performance shear (downdraft, decreasing headwind, or increasing tailwind) with a magnitude that is greater than or equal to that shown in the shear intensity curve shown in Figure 1.
- (ii) This warning alert shall display or provide an appropriate output for display of a red warning annunciation labelled 'wind shear' dedicated for this purpose. The visual alert should remain at least until the threshold wind shear condition no longer exists, or for a minimum of 3 seconds, whichever is greater. An aural alert shall be provided that annunciates 'wind shear' for 3 aural cycles. The aural alert need not be repeated for subsequent wind shear warning alerts within the same mode of operation.
- (iii) Gust conditions shall not cause a nuisance warning alert. Turbulence shall not cause more than 1 nuisance warning alert per 250 hours (or 3 000 flight cycles based on 1 hour/flight) of system operation.

(5) Wind shear alert with increased approach sensitivity and reduced take-off sensitivity modes

- (i) Increased approach sensitivity mode. If the system separates the approach and take-off scenarios, the crew may reduce the shear intensity level in the approach mode to increase the probability of providing timely wind shear alerts. They may lower the floor of the shear intensity curve 'must alert' curve in Figure 1 from 0.105 to 0.090. If they lower the floor, they may also modify the turbulence rejection tests in paragraph 4(d)(7)(ii) such that an alert in this region is not a failure of the turbulence rejection test.
- (ii) Reduced take-off sensitivity mode. If the system separates the approach and take-off scenarios, the crew may desensitise the take-off mode to reduce the probability of unwanted alerts. They may raise the floor of the shear intensity 'must alert' curve in Figure 1 from 0.105 to 0.120.

- (iii) Additional reduced take-off sensitivity mode. Some high-performance jet aeroplanes receive unwanted wind shear alerts after take-off when climbing at high rates through atmospheric wind gradients. If these unwanted alerts risk desensitising pilots to wind shear alerting, the crew may tailor the floor of the shear intensity 'must alert' curve in Figure 1 to reduce these unwanted alerts under the following conditions:
- (a) The airborne wind shear warning and escape guidance system can determine that the aeroplane is in the take-off versus approach phase.
 - (b) The aeroplane is climbing at a high rate of climb, the aeroplane continues to climb at a high rate, and the rate of climb is known to create unwanted wind shear alerts.
 - (c) The aeroplane power setting is at or near a level that is representative of the maximum for the segment of the take-off; for example, maximum take-off thrust.
 - (d) The Figure 1 shear intensity 'must alert' curve shall be complied with after take-off.
- (6) Alerting prioritisation
- If alerting is prioritised in the presentation for a wind shear warning and escape guidance system (reactive wind shear), forward-looking wind shear system, terrain awareness and warning system, ground proximity warning system, traffic collision avoidance system, or when a simultaneous aural annunciation could occur, sequencing shall be implemented that ensures that reactive wind shear warning alerts are presented or annunciated first. Reactive wind shear alerts that are cautions have a lower priority than all terrain awareness and warning or ground proximity warning system alerts.
- (7) The reactive wind shear systems caution alert should be disabled if a forward-looking wind shear system is in operation. It is acceptable to issue reactive wind shear caution alerts if the forward-looking wind shear system is inoperative.
- (8) Operating altitude range
- The system shall be designed to function from at least 50 feet above ground level (AGL) to at least 1 000 feet AGL.
- (9) Wind shear escape guidance
- Flight guidance algorithms shall incorporate the following design considerations:
- (i) At the point of the system warning threshold, the available energy of the aeroplane shall be properly managed through a representative number of wind field conditions. These conditions shall take into account significant shear components in both the horizontal and vertical axes, individually and in combination.
 - (ii) The flight path guidance commands shall be suitable for the dynamic response of aeroplane of the type on which the system is intended for installation. The applicant shall demonstrate that the flight guidance commands during a dynamic wind shear encounter can be followed without resulting in pilot-induced oscillations.

- (iii) If the magnitude of the shear components is such as to overcome the performance capability of the aeroplane, guidance commands shall be such that a ground impact will occur in the absence of the ability to produce additional lift, an absence of excessive kinetic energy, and without putting the aeroplane into a stalled condition.
- (iv) Flight guidance command information shall be provided for presentation on the primary flight display/attitude direction indicator (PFD/ADI) and any available head-up display (HUD).
- (v) Flight guidance displays which command the flight path and pitch attitude should be limited to an angle of attack that is equivalent to the onset of a stall warning or a maximum pitch command of 27°, whichever is less.
- (vi) Flight guidance commands and any auto recovery mode (if included) may be automatically activated concurrently with or after the wind shear warning alert occurs, or may be manually selected. If manual selection is utilised, it shall only be via the take-off/go-around (TOGA) switch or equivalent means (i.e. a function of the throttle position, other engine parameters, etc.).
- (vii) Manual deselection of wind shear flight guidance and any auto recovery mode (if included) shall be possible by means other than the TOGA switches.
- (viii) Systems that incorporate the automatic reversion of flight guidance commands from wind shear escape guidance to another flight guidance mode should provide a smooth transition between the modes. Flight guidance commands shall not be removed from the flight guidance display until either they are manually deselected or until the aeroplane, following the end of the warning conditions, has maintained a positive rate of climb and speed above 1.3 Vs1 for at least 30 seconds.

FIGURE 1 — SHEAR INTENSITY CURVE

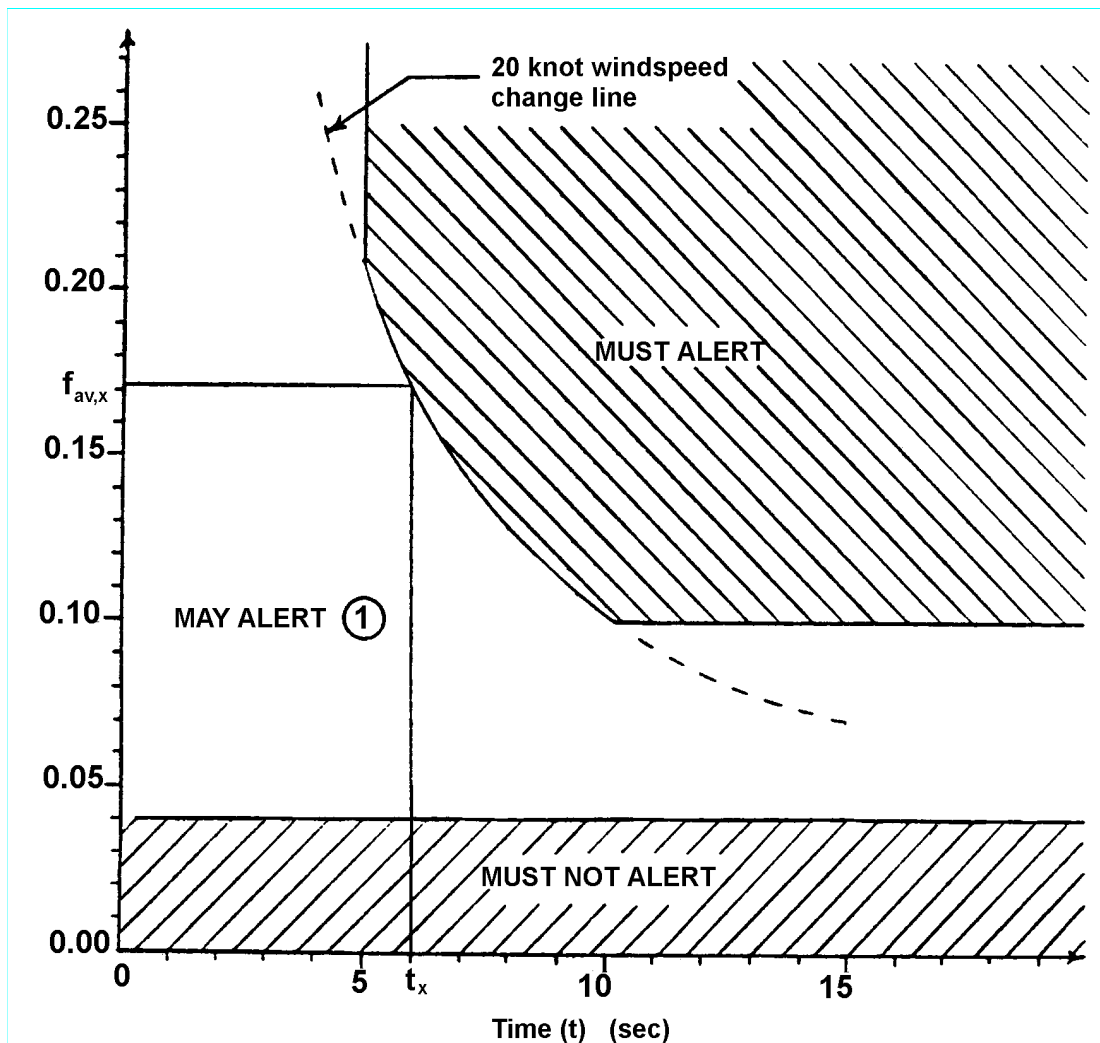

$f_{av,x}$ = average shear intensity to cause a warning at time t_x (resulting in a 20-knot wind speed change, bounded as shown; applies to horizontal, vertical, and combination shear intensities),

$$= \frac{\int_0^{t_x} f(t) dt}{t_x},$$

whereby $f(t)$ = instantaneous shear intensity at time t .

- ① A nuisance warning test that utilises the Dryden turbulence model and discrete gust model is conducted independently from the alert threshold tests to verify the acceptability of potential nuisance warnings due to turbulence or gusts.

- c. Equipment performance — environmental conditions
- (1) The environmental tests and performance requirements described in this subsection are intended to provide a laboratory means to determine the overall performance characteristics of the equipment under conditions that are representative of those that may be encountered in actual operations. Table 1 defines the environmental tests that are required for the equipment. It shows the section numbers in ED-14G that describe the individual environmental tests. Some of the environmental tests contained in this subsection do not need to be performed unless the manufacturer wishes to qualify the equipment for that particular environmental condition. These tests are identified by the phrase ‘When required’ in Table 1. If the manufacturer wishes to qualify the equipment to these additional environmental conditions, then these ‘When required’ tests shall be performed.
 - (2) Environmental requirements. The following subset of performance requirements shall be met under the environmental conditions required by paragraph 3.1.2 of this ETSO. Additionally, all the system controls, displays, inputs and outputs shall perform their intended functions when subjected to the ED-14G environmental conditions.
 - (i) Section 4.b(1) — Mode Annunciation
 - (ii) Section 4.b(2) — Malfunction/Failure Indications
 - (iii) Section 4.b(3) — Wind Shear Caution Alert, except paragraph 4.b(3)(iii)
 - (iv) Section 4.b(4) — Wind Shear Warning Alert, except paragraph 4.b(4)(iii)
 - (v) Section 4.b(5) — Wind Shear Alert with Increased Approach Sensitivity and Reduced Take-off Sensitivity Modes
 - (vi) Section 4.b(9) — Wind Shear Escape Guidance
 - (3) The applicant shall conduct environmental qualification tests for the following shear intensity ($f_{av,x}$) and exposure time (s) in Figure 1: 0.1050, 10; 0.1748, 6; and 0.2100, 5; and ensure that the system generates and displays alerts when required. A single representative wind shear waveform may be used for all the environmental tests if the system design is such that different waveforms will not affect the performance under environmental conditions. Gust and turbulence rejection tests are not required under environmental conditions.

Table 1 — Required EUROCAE ED-14G Testing by Category

Environmental Test	ED-14G Section	Required Test
Temperature and Altitude	4	
Ground Survival Low Temperature and Short-Time Operating Low Temperature		√
Low Operating Temperature		√

Ground Survival High Temperature and Short-Time Operating High Temperature		√
High Operating Temperature		√
In-Flight Loss of Cooling		When required
Altitude		√
Decompression		When required
Overpressure		When required
Temperature Variation	5	√
Humidity	6	√
Operational Shocks and Crash Safety	7	
Operational Shocks		√
Crash Safety		√
Vibration	8	√
Explosion Proofness	9	When required
Waterproofness	10	
Condensing Water Proof		When required
Drip Proof		When required
Spray Proof		When required
Continuous Stream Proof		When required
Fluids Susceptibility	11	
Spray		When required
Immersion		When required
Sand and Dust	12	When required
Fungus Resistance	13	When required
Salt Spray	14	When required
Magnetic Effect	15	√
Power Input	16	
Normal Operating Conditions (AC/DC)		√
Abnormal Operating Conditions (AC/DC)		√
Load Equipment Influence on Aeroplane Electrical Power System (AC/DC)		When required
Voltage spike	17	
Category A Requirements (If applicable)		√
Category B Requirements (If applicable)		√
Audio frequency conducted susceptibility	18	√

Induced Signal Susceptibility	19	√
RF Susceptibility	20	√
Emission of RF Energy	21	√
Lightning-induced Transient Susceptibility	22	√
Lightning Direct Effects	23	When required
Icing	24	When required
Electrostatic Discharge	25	When required
Fire, Flammability	26	√

d. Equipment test procedures

(1) Definitions of terms and conditions of tests. The following definitions of terms and conditions of tests are applicable to the equipment tests specified herein:

- (i) Power input voltage. Unless otherwise specified, all the tests shall be conducted with the power input voltage adjusted to the design voltage ± 2 per cent. The input voltage shall be measured at the input terminals of the equipment under test.
- (ii) Power input frequency
 - (a) In the case of equipment that is designed for operation from an AC power source of essentially constant frequency (e.g. 400 Hz), the input frequency shall be adjusted to the design frequency ± 2 per cent.
 - (b) In the case of equipment designed for operation from an AC power source of variable frequency (e.g. 300 to 1 000 Hz), unless otherwise specified, the test shall be conducted with the input frequency adjusted to within 5 % of a selected frequency and within the range for which the equipment is designed.
- (iii) Wind field models. Unless otherwise specified, the wind field models used for the tests shall be those specified in Appendix 2 to ETSO-C117b.
- (iv) Adjustment of equipment. The circuits of the equipment under test shall be aligned and adjusted in accordance with the manufacturer's recommended practices prior to the application of the specified tests.
- (v) Test instrument precautions. Due precautions shall be taken during the execution of the tests to prevent the introduction of errors that result from the connection of voltmeters, oscilloscopes, and other test instruments across the input and output impedances of the equipment under test.
- (vi) Ambient conditions. Unless otherwise specified, all the tests shall be made within the following ambient conditions:
 - Temperature: + 15 to + 35 °C (+ 59 to + 95 °F)
 - Relative humidity: Not greater than 85 %
 - Ambient pressure: 84–107 kPa (equivalent to + 5 000 to – 1 500 ft) (+ 1 525 to – 460 m)

- (vii) Warm-up period. Unless otherwise specified, all the tests shall be conducted after the manufacturer's specified warm-up period.
 - (viii) Connected loads. Unless otherwise specified, all the tests shall be performed with the equipment connected to loads which have the impedance values for which it is designed.
- (2) Test procedures. The equipment shall be tested in all the modes of operation that allow different combinations of sensor inputs to show that it meets both the functional and accuracy criteria.

Dynamic testing provides quantitative data regarding the performance of wind shear warning and escape guidance equipment using a simplified simulation of flight conditions. This testing, when properly performed and documented, may serve to minimise the flight test requirements.

It shall be the responsibility of the equipment manufacturer to determine that the sensor inputs, when presented to the wind shear warning and escape guidance equipment, will produce performance that is commensurate with the requirements of this standard. Additional sensor inputs may be optionally provided to enhance the capability and/or performance of the equipment.

The equipment required to perform these tests shall be defined by the equipment manufacturer as a function of the specific sensor configuration of the equipment. Since these tests may be accomplished in more than one way, alternative test equipment set-ups may be used where equivalent test functions can be accomplished. Combinations of tests may be used wherever appropriate.

The signal sources of the test equipment shall provide the appropriate signal formats for input to the specific system under test without contributing to the error values that are being measured. Tests need only be performed once, unless it is otherwise indicated.

The scenarios that are established for testing wind shear warning and escape guidance systems represent realistic operating environments to properly evaluate such systems. The wind field models contained in Appendix 2 to ETSO C117b should be used to evaluate the performance of the wind shear warning and escape guidance systems. The manufacturer may propose different wind field models provided that it is shown that they represent conditions that are at least as severe as those contained in this ETSO.

- Note: The test waveform parameters provided in this ETSO are sufficiently broad to cover the wind field parameters that were observed in the known accident cases. However, the manufacturer is encouraged to verify that the detection systems will actually detect these wind shears by subjecting them to the wind field conditions specified for use in evaluating guidance commands.
- (3) Test set-up. Simulator tests shall be used to demonstrate the performance capability of the wind shear warning and escape guidance equipment. A suitable equipment interface shall be provided for recording the relevant parameters that are necessary to evaluate the particular system under test. The aeroplane simulator shall be capable of appropriate dynamic modelling of a representative aeroplane and of the wind field and turbulence conditions contained in Appendices 2 and 3 to this ETSO, or other wind field/turbulence models that are found to be acceptable by the administrator.

Note: This section requires testing in a single representative aeroplane simulator. Approval of the installation will require system testing in an aeroplane simulator that is representative of the aeroplane. Thus, we recommend you to accomplish the paragraph 4(d)(3) simulator testing in as many representative simulators as are necessary to cover all the intended installations.

- (4) Functional performance (paragraphs 4(b)(1) through 4(b)(5), 4(b)(8) and 4(b)(9)). Each of the functional capabilities identified in paragraphs 4(b)(1) through 4(b)(5), 4(b)(7) and 4(b)(8) shall be demonstrated with the wind shear warning and escape guidance equipment powered. These capabilities shall be evaluated either by inspection or in conjunction with the tests described in paragraphs 4(d)(5) through 4(d)(10).
- (5) Mode annunciation (paragraph 4(b)(1)). With the equipment operating, verify that the wind shear escape guidance display mode of operation is annunciated to the pilot upon activation of the escape guidance and upon reversion to a different flight guidance mode.
- (6) Malfunction/failure indications (paragraph 4(b)(2)). Configure the equipment for simulation tests as defined in paragraph 4(d)(3).
 - (i) With the system active (within the operating altitude range) and inactive (outside the operating altitude range), remove one at a time each required electrical power input to the equipment. There shall be a failure indication by the equipment of each simulated failure condition.
 - (ii) With the system active (within the operating altitude range) and inactive (outside the operating altitude range), cause each sensor or other signal input to become inadequate or invalid. There shall be a failure indication by the equipment of each simulated failure condition.
- (7) Wind shear caution alert (paragraphs 4(b)(3) and 4(b)(5)(i)). For equipment that incorporates a wind shear caution alert function, accomplish the following tests:
 - (i) Configure the equipment for a simulation test as defined in paragraph 4(d)(3). Subject the equipment to acceleration waveform values that meet the following conditions (reference Figure 2). The system shall generate an appropriate caution alert (or no alert) within the time intervals specified when subjected to the following average shear intensity ($f_{av,x}$) values:

$f_{av,x}$ (1)	Time of Exposure (t) (s)	Alert within (s) (3)
0.0200	20	no alert
0.0400	20	no alert
0.1050	10	10
0.1166	9	9
0.1311	8	8
0.1499	7	7
0.1748	6	6.2
0.2100	5	5.7
0.2700 (2)	5	5

Notes:

- (1) The average shear intensity which shall result in a caution alert after a time t_x or less meets the definition of $f_{av,x}$ in Figure 1. The maximum instantaneous shear intensity of the test waveform is restricted to 0.075 or 100 % of $f_{av,x}$ above the average shear value $f_{av,x}$, whichever is less. The minimum instantaneous shear intensity of the test waveform is zero. The test waveform rise and fall rates shall be limited to a maximum of 0.1 per second. The shear intensity before time 0 is zero for a sufficiently long time to allow the system to settle to stable conditions.
- (2) In order to achieve the test condition with the shear intensity $f_{av,x}$ equal to or greater than 0.270, it is necessary to have an initial rise of sufficient rate to achieve a shear intensity f value that will allow subsequent rise and fall rates that are limited to 0.1 per second to achieve the required $f_{av,x}$ value.
- (3) Account for latency due to the alert calculation and alert annunciation display functionality when measuring the alert time

The test conditions specified above shall be repeated 5 times for each axis (horizontal and vertical). A total of 90 runs are required for verification of the detection (9 conditions \times 5 for each axis) for both performance increasing and performance decreasing wind shears. A different waveform for $f_{av,x}$ will be utilised for each of the 5 runs. An appropriate alert (or no alert) shall be generated for each test condition.

Verify that the system displays or provides an appropriate output for display of an amber caution annunciation that is dedicated for this purpose. Verify that the visual caution display (or output) remains at least until the threshold wind shear condition no longer exists, or a minimum of 3 seconds (whichever is greater), or until a wind shear warning occurs.

- (ii) Subject the equipment to wind speeds that are defined by the Dryden

turbulence model contained in Appendix 4 to ETSO C117b. The system shall be exposed to these conditions for a minimum of 50 hours (or 600 flight cycles) at each altitude specified in Appendix 4 to ETSO C117b for a minimum total test duration of 250 hours (or 3 000 flight cycles based on 1 hour/flight cycle).

No more than 1 nuisance caution shall be generated during this test.

An alternative test equipment set-up may be used to accomplish the equivalent test function for the turbulence testing. A combination of analysis, simulation and testing may be used to demonstrate the performance of the equipment.

- (iii) Subject the equipment to the wind speeds that are defined by the discrete gust rejection model contained in Appendix 4 to ETSO C-117b. No alert shall be generated as a result of this test.
- (8) Wind shear warning alert (paragraphs 4(b)(4) and 4(b)(5)(ii)).
- (i) Configure the equipment for simulation tests as defined in paragraph 4(d)(3). Subject the equipment to acceleration waveform values that meet the following conditions (reference Figure 2). The system shall generate an appropriate warning alert (or no alert) within the time intervals that are specified when it is subjected to the following average shear intensity ($f_{av,x}$) values:

$f_{av,x}$ (1)	Time of Exposure (t) (s)	Alert within (s) (3)
0.0200	20	no alert
0.0400	20	no alert
0.1050	10	10
0.1166	9	9
0.1311	8	8
0.1499	7	7
0.1748	6	6.6
0.2100	5	6.2
0.2700 (2)	5	5.7

Notes:

- (1) The average shear intensity which shall result in a warning alert after a time t_x or less meets the definition of $f_{av,x}$ in Figure 1. The maximum instantaneous shear intensity of the test waveform is restricted to 0.075 or 100 % of $f_{av,x}$ above the average shear value $f_{av,x}$, whichever is less. The minimum instantaneous shear intensity of the test waveform is zero. The test waveform rise and fall rates shall be limited to a maximum of 0.1 per second. The shear intensity before time 0 is

zero for a sufficiently long time to allow the system to settle to stable conditions.

- (2) In order to achieve the test condition with the shear intensity $f_{av,x}$ equal to or greater than 0.270, it is necessary to have an initial rise of a sufficient rate to achieve a shear intensity f value that will allow the subsequent rise and fall rates that are limited to 0.1 per second to achieve the required $f_{av,x}$ value.
- (3) Account for any latency due to the alert calculation and alert annunciation display functionality when measuring the alert time.

The test conditions specified above shall be repeated 5 times for each axis (horizontal and vertical). A total of 90 runs are required for verification of the detection (9 conditions \times 5 for each axis) for both performance increasing and performance decreasing wind shears. A different waveform for $f_{av,x}$ will be utilised for each of the 5 runs. An appropriate alert (or no alert) shall be generated for each test condition.

Verify that the system displays or provides an appropriate output for display of a red warning annunciation labelled 'wind shear' that is dedicated for this purpose. Verify that the visual warning display (or output) remains until the threshold wind shear condition no longer exists, or a minimum of 3 seconds, whichever is greater. Verify that an aural alert is provided that annunciates 'wind shear' for 3 aural cycles.

- (ii) Subject the equipment to the wind speeds that are defined by the Dryden turbulence model contained in Appendix 4 to ETSO C117b. The system shall be exposed to these conditions for a minimum of 50 hours (or 600 flight cycles) at each altitude specified in Appendix 4 to ETSO C117b for a minimum total test duration of 250 hours (or 3 000 flight cycles based on 1 hour/flight cycle). No more than 1 nuisance warning shall be generated during this test.

An alternative test equipment set-up may be used to accomplish the equivalent test function for the turbulence testing. A combination of analysis, simulation, and testing may be used to demonstrate the performance of the equipment specified in this paragraph 4(d)(8)(ii).

- (iii) Subject the equipment to the wind speeds that are defined by the discrete gust rejection model contained in Appendix 4 to ETSO-C117b. No alerts shall be generated as a result of this test.

FIGURE 2 — WIND SHEAR ALERT TEST

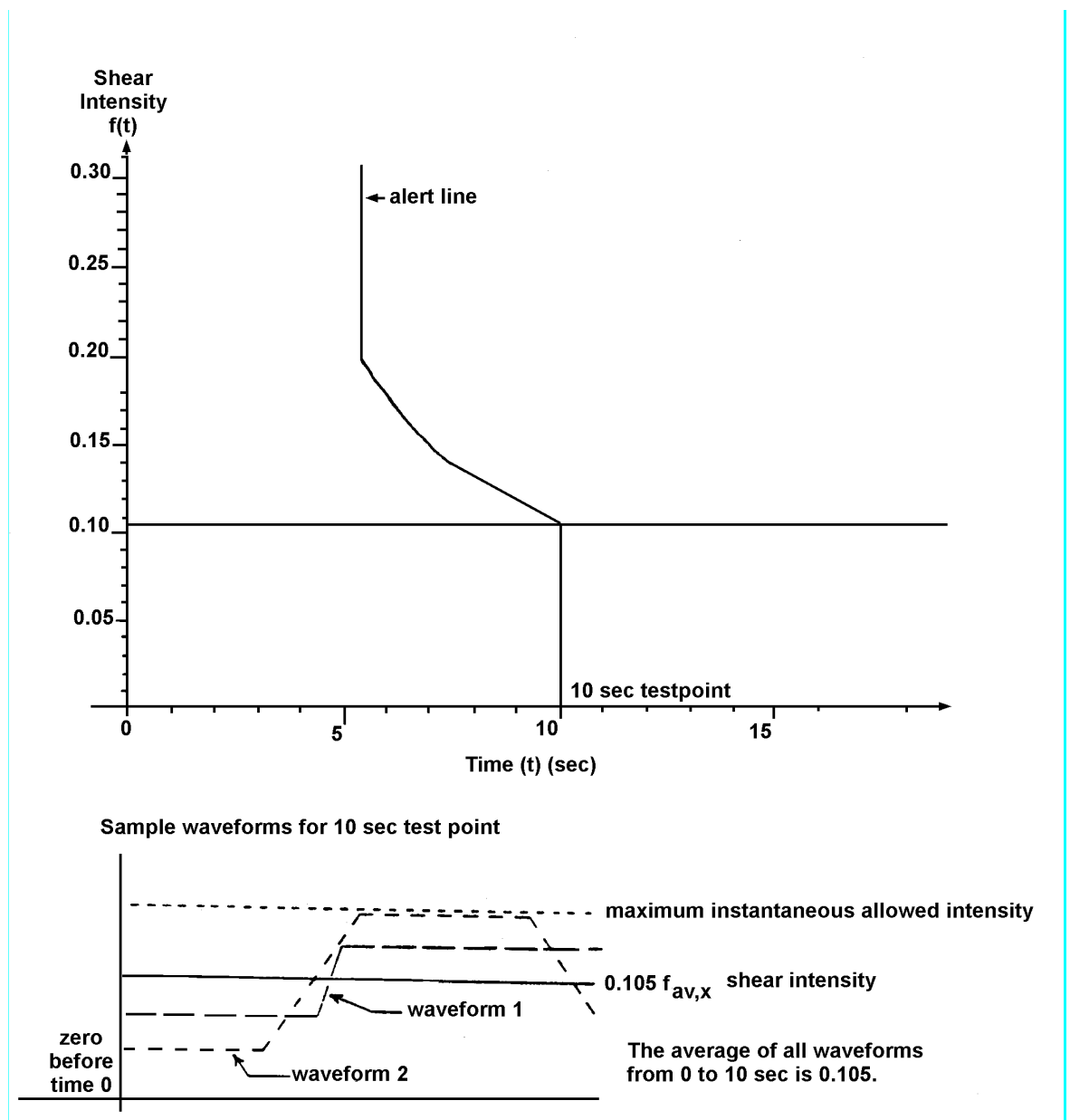

- (9) Operating altitude range (paragraph 4.b(8)). Configure the equipment for the simulation tests as defined in paragraph 4(d)(3). Simulate a take-off to an altitude of at least 1 500 feet AGL. Verify the wind shear warning and escape guidance system is operational from at least 50 feet AGL to at least 1 000 feet AGL. Simulate an approach to landing from 1 500 feet AGL to touchdown. Verify the wind shear warning and escape guidance system is operational from at least 1 000 feet AGL to at least 50 feet AGL.
- (10) Wind shear escape guidance (paragraph 4.b(9)). Configure the equipment for simulation tests as defined in paragraph 4(d)(3). Subject the equipment to each of the wind field conditions contained in Appendix 2 to ETSO C117b for each operating mode (take-off, approach, landing, etc.) that is available. Each test condition shall be repeated 5 times. Recovery actions for the fixed pitch method comparison shall be initiated immediately upon entering the shear condition.

Notes:

- (1) Evaluate wind shear escape guidance commands using a simulation that incorporates the necessary dynamic modelling of the representative aeroplane (more than 1 representative aeroplane model may be necessary) in which installation of the equipment is intended. Dynamic modelling of the representative aeroplane should include consideration of all the relevant effects, including but not limited to pitch and roll rates, control authority, delays between control inputs and aeroplane responses, display system leads and lags, etc.
- (2) The simulator should provide for a pilot in the loop evaluation of guidance flyability during simulated wind shear encounters. The guidance command gains should be consistent with those incorporated in the flight guidance system. While ‘fine-tuning’ of the guidance commands to obtain the optimum performance for a specific aeroplane may be accomplished, the use of unique tailoring for a specific aeroplane may not be necessary. Evaluation through means of a suitable engineering simulation may be acceptable to demonstrate the suitability of the guidance commands for a representative aeroplane. However, the equipment manufacturer should demonstrate that the flight guidance commands during a dynamic wind shear encounter can be followed without resulting in pilot-induced oscillations.
 - (i) Verify that the flight path guidance commands manage the available energy of the aeroplane to achieve the desired trajectory through the shear encounter. These tests shall be performed with vertical only, horizontal only, and a combination of vertical and horizontal shear conditions. You may reduce the number of times you repeat each of these tests conditions to less than 5. To reduce the number of repetitions to less than 5, you shall have gathered sufficient data to demonstrate that the flight path guidance commands meet these requirements. You should also include aeroplane weight and centre of gravity variations if applicable.
 - a. For the take-off case, verify that the flight guidance commands produce a trajectory that provides a resultant flight path that is at least as good (when considered over the entire spectrum of test cases) as that obtained by establishing a 15° pitch attitude (at an approximate rate of 1.5° per second) until the onset of a stall warning, and then reducing the pitch attitude to remain at the onset of a stall warning until the shear condition is exited. Evidence of a significant decrement (considered over the entire spectrum of test cases) below the flight path that is provided by the fixed pitch method that results from the use of the guidance commands provided by the system shall be adequately substantiated.
 - b. For the approach/landing case, verify that the flight guidance commands produce a trajectory that provides a resultant flight path that is at least as good (when considered over the entire spectrum of test cases) as that obtained by establishing the maximum available thrust and a 15° pitch attitude (at an approximate rate of 1.5° per

second) until the onset of stall warning, and then reducing the pitch attitude to remain at the onset of stall warning until the shear condition is exited. Evidence of a significant decrement (considered over the entire spectrum of test cases) below the flight path that is provided by the fixed pitch method that results from the use of the guidance commands that are provided by the system shall be adequately substantiated.

- c. For shear conditions that exceed the available performance capability of the aeroplane, verify that the flight guidance commands result in a ground impact in the absence of the ability to produce additional lift, an absence of excessive kinetic energy, and without putting the aeroplane into a stalled condition.

Note: There is no requirement to perform the tests described in paragraphs 4(d)(10)(ii) through (vii) with horizontal only, vertical only, and a combination of vertical and horizontal shear conditions. You may perform the tests described in paragraphs 4(d)(10)(ii) through (vii) with only the combination vertical and horizontal shear conditions.

- (ii) Verify that the flight guidance command outputs are capable of display on the associated flight displays. The interface specifications shall be verified and determined to be appropriate for the systems that are identified in the equipment installation instructions.
- (iii) Verify that the pitch attitude commands do not result in an angle of attack that exceeds the onset of a stall warning or a maximum pitch command of 27°, whichever is less.
- (iv) For systems that incorporate manual activation of recovery flight guidance commands, verify that the system is activated only by the TOGA switches (or equivalent means). For systems that provide automatic activation of recovery guidance, verify that the system is activated concurrently with the wind shear warning alert.
- (v) Verify that the wind shear recovery guidance commands and any automatic recovery mode can be deselected by a means other than the TOGA switches.
- (vi) For systems that incorporate automatic reversion of flight guidance commands from wind shear escape guidance to another flight guidance mode, verify that the transition between the flight guidance modes provides smooth guidance information.

Verify that flight guidance commands are not removed from the flight guidance display until either they are manually deselected or until the aeroplane, following the exit of the warning conditions, has maintained a positive rate of climb and speed above 1.3 Vs1 for at least 30 seconds.

[Amdt ETSO/16]

Appendix 2 to ETSO-C117b – Wind Field Models and Data

ED Decision 2020/011/R

This Appendix contains data that defines the wind field models to be used in conducting the tests specified in paragraph 4(d)(10) of this ETSO. This material was developed by the National Aeronautics And Space Administration (NASA), reference NASA Technical Memorandum 100632 [ref. 1].

The downburst model parameters below provide the variables to be used to obtain the representative test conditions: (1) and (2)

Radius of Downdraft (ft)	Maximum Outflow (ft/s)	Altitude of Max. Outflow (ft)	Distance from Starting Point (3) (ft)
920	37	98	20000 (-9000)
1180	47.6	98	15000 (-14000)
2070	58.4	131	25000 (-4000)
4430	68.9	164	30000 (1000)
9010	72.2	262	30000 (1000)
3450	88.2	197	25000 (-4000)
3180	53.1	262	30000 (1000)
1640	46	164	25000 (-4000)
5250	81.3	197	30000 (1000)
1250	67.6	100	25000 (-4000)

- (1) From analytic microburst model documented in NASA TM-100632. These parameters are based on data from Proctor’s Terminal Area Simulation System (TASS) model.
- (2) For the takeoff case, the downburst centre is positioned at the point the aeroplane lifts off the runway for all test cases.
- (3) For the approach/landing case, the downburst centre is positioned as stated. The test is begun with the aeroplane at an initial altitude of 1 500 feet on a 3° glideslope (touchdown point approximately 29 000 feet away). The distance from the starting point indicates where the centre of the downburst shaft is located relative to the starting point. The number in parentheses next to it indicates the relative distance of the microburst centre from the touchdown point (not the end of the runway). A negative number indicates that the microburst centre is located before the touchdown point, positive indicates it is past the touchdown point.

SUMMARY

A simple downburst model has been developed for use in batch and real-time piloted simulation studies of guidance strategies for terminal area transport aeroplane operations in wind shear conditions. The model represents an axisymmetric stagnation point flow, based on velocity profiles from the Terminal Area Simulation System (TASS) model developed by Proctor [ref. 3,4] and satisfies the mass continuity equation in cylindrical coordinates. Altitude dependence, including boundary layer effects near the ground, closely matches real-world measurements, as do the increase, peak, and decay of outflow and downflow with increasing distance from the downburst centre. Equations for horizontal and vertical winds were derived, and found to be infinitely differentiable, with no singular points existent in the flow field. In addition, a simple relationship exists among the ratio of maximum horizontal to vertical velocities, the downdraft radius, depth of outflow, and altitude of maximum outflow. In use, a microburst can be modelled by specifying four characteristic parameters. Velocity components in the x, y, and z directions, and the corresponding nine partial derivatives are obtained easily from the velocity equations.

INTRODUCTION

Terminal area operation of transport aircraft in a wind shear environment has been recognised as a serious problem. Studies of aeroplanes trajectories through downbursts show that specific guidance strategies are needed for aeroplanes to survive inadvertent downburst encounters. In order for guidance strategies to perform in simulations as in actual encounters, a realistic set of conditions must be present during development of the strategies. Thus, aeroplane and wind models that closely simulate real-world conditions are essential in obtaining useful information from the studies.

Wind models for use on personal computers, or for simulators with limited memory space availability, have been difficult to obtain because variability of downburst characteristics makes analytical models unrealistic, and large memory requirements make the use of numerical models impossible on any except very large capacity computers.

Bray [ref. 2] developed a method for analytic modelling of wind shear conditions in flight simulators, and applied his method in modelling a multiple downburst scenario from Joint Airport Weather Studies (JAWS) data. However, the altitude dependence of his model is not consistent with observed data and, although flexibility in sizing the downbursts is built into the model, it does not maintain the physical relationships which are seen in real-world data among the sizing parameters. In particular, boundary layer effects should cause the radial velocity to decay vertically to zero at the ground, as does the vertical velocity.

In a study conducted at NASA Langley Research Center, three different guidance strategies for a Boeing 737-100 aeroplane encountering a microburst on take-off were developed [ref. 3-4]. These strategies were first developed using a personal computer, and then implemented in a pilot-in-the-loop simulation using a very simple wind model in both efforts. The wind velocities used are depicted in Figure 1. This model consisted of a constant outflow outside of the downburst radius and a constant slope headwind to tailwind shear across the diameter of the downburst.

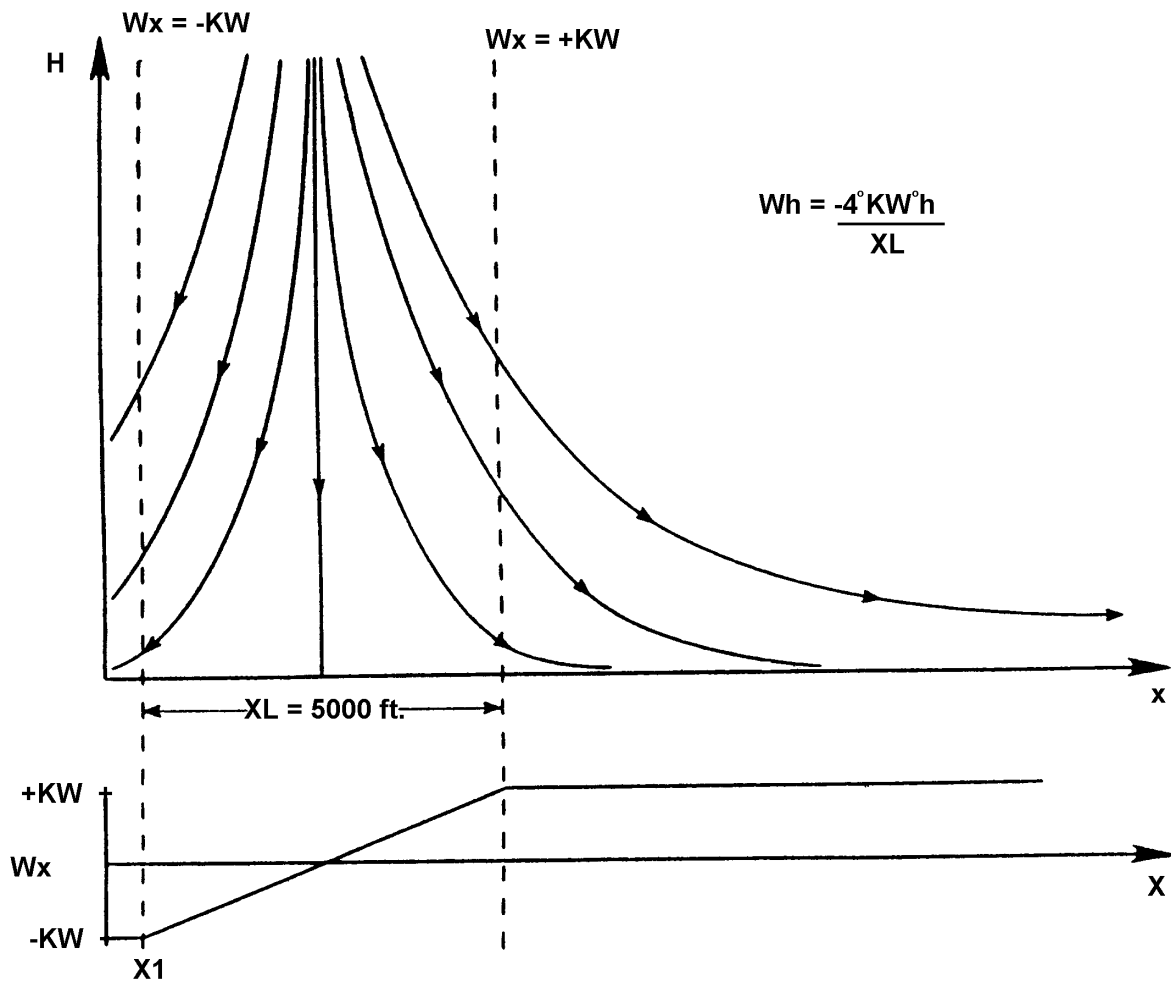

Figure 1 — Wind Model Used in Guidance Studies

It was recognised that a more realistic wind model could significantly alter the outcome of the trajectory. For the subsequent part of this study, which involves altering the aeroplane model to simulate approach to landing and escape manoeuvres and additional take-off cases, a more realistic wind model was preferred. The simple analytical model outlined in this report was developed for this purpose.

SYMBOLS

JAWS	Joint Airport Weather Studies
NIMROD	Northern Illinois Meteorological Research on Downbursts
R	radius of downburst shaft (ft)
r	radial coordinate (distance from downburst centre) (ft)

TASS	Terminal Area Simulation System
u	velocity in r-direction (or x-direction) (knots)
v	velocity in y-direction (knots)
w	velocity in z-direction (knots)
w _{max}	magnitude of maximum vertical velocity (knots)
u _{max}	magnitude of maximum horizontal velocity (knots)
x	horizontal (runway) distance, aeroplane to downburst centre (ft)
y	horizontal (side) distance, aeroplane to downburst centre (ft)
z	aeroplane altitude above ground level (ft)
z _h	depth of outflow (ft)
z _m	height of maximum U-velocity (ft)
z _{m2}	height of half-maximum U-velocity (ft)
z*	characteristic height, out of boundary layer (ft)
e	characteristic height, in boundary layer (ft)
λ	scaling factor (s-1)

DEVELOPMENT OF VELOCITY EQUATIONS

Beginning with the full set of Euler and mass continuity equations, some simplifying assumptions about the downburst flow conditions were made. Effects of viscosity were parameterised explicitly, and the flow was assumed to be invariant with time. The downburst is axisymmetric in cylindrical coordinates, and characterized by a stagnation point at the ground along the axis of the downflow column. The flow is incompressible, with no external forces or moments acting on it.

The resulting mass conservation equation is

$$\nabla \cdot v = 0. \quad (1)$$

Written out in full, equation 2 is

$$\frac{\partial u}{\partial r} + \frac{\partial w}{\partial z} + \frac{u}{r} = 0. \quad (2)$$

This equation is satisfied by solutions of the form

$$w = g(r^2)q(z) \quad (3a)$$

$$u = \frac{f(r^2)}{r}p(z) \quad (3b)$$

provided that

$$f'(r^2) = \frac{\lambda}{2}g(r^2) \quad (4a)$$

$$q'(z) = \lambda p(z). \quad (4b)$$

Note that $f'(r^2) = \frac{\partial f(r^2)}{\partial r^2}$. To solve this system of equations, solutions were assumed for two of the functions and the other two were obtained from equations 4a and 4b.

It was desired that the velocity profiles of this analytic model exhibit the altitude and radial dependence shown in the large-scale numerical TASS (Terminal Area Simulation System) weather model [ref. 6-9]. The TASS model is based on data from the Joint Airport Weather Studies (JAWS) [ref. 10], and provides a three-dimensional velocity field, frozen in time, for given locations of an aeroplane within the shear [ref. 11-12].

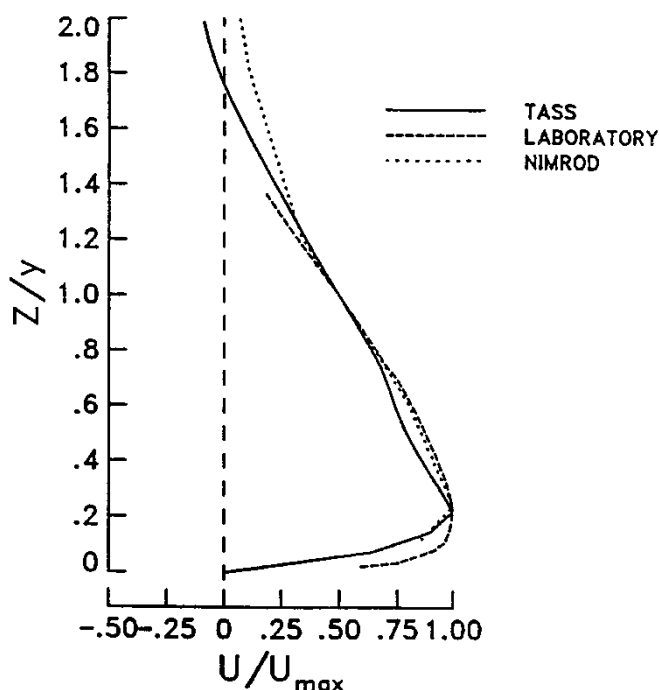

Figure 2 — Vertical Profile of Microburst Outflow (Non-dimensional)

Figure 2 shows dimensionless vertical profiles of horizontal velocity, u , for TASS data, laboratory data obtained by impingement of a jet on a flat plate, and data from NIMROD (Northern Illinois Meteorological Research on Downbursts) [ref. 13-21]. Specific points of interest are the maximum horizontal velocity (located 100-200 metres above the ground), below which is a decay region due to boundary layer effects, zero velocity at the stagnation point on the ground, and an exponential decay with altitude above the maximum velocity altitude. Vertical velocity profiles from TASS data are shown in Figure 3, also exhibiting a decay to zero at the stagnation point.

VERTICAL PROFILES OF VERTICAL VELOCITY FOR 30 JUN 82 CASE:
SENSITIVITY TO RADIUS OF PRECIPITATION SHAFT

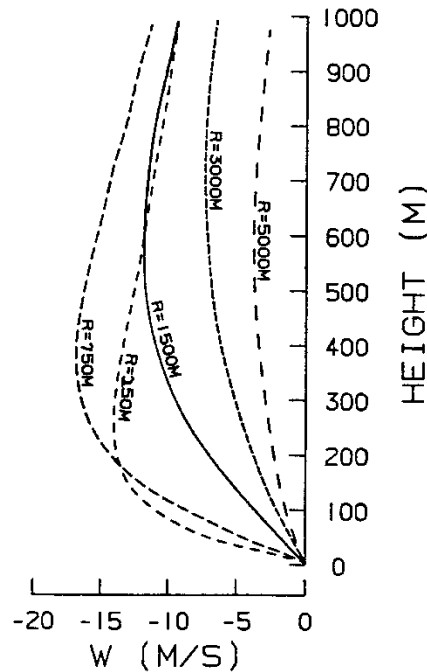

Figure 3 — Vertical Profile of Microburst Downflow

The radially varying characteristics desired for the horizontal wind were two peaks of equal magnitude and opposite direction located at a given radius, with a smooth, nearly linear transition between the two. Beyond the peaks, the velocity should show an exponential decay to zero. The vertical velocity was required to have a peak along the axis of symmetry ($r = 0$), and to decay exponentially as the radius increases.

A pair of shaping functions that gave velocity profiles matching the TASS data as required are given below.

$$g(r^2) = e^{-(r/R)^2}$$

$$p(z) = e^{-z/z^*} - e^{-z/\varepsilon}$$

The remaining solutions were found by integrating equations 4a and 4b, yielding:

$$f'(r^2) = \frac{\lambda R^2}{2} [1 - e^{-(r/R)^2}]$$

$$q(z) = -\lambda \{ \varepsilon (e^{-z/\varepsilon} - 1) - z * (e^{-z/z^*} - 1) \}$$

Figures 4 and 5 show plots of these shaping functions.

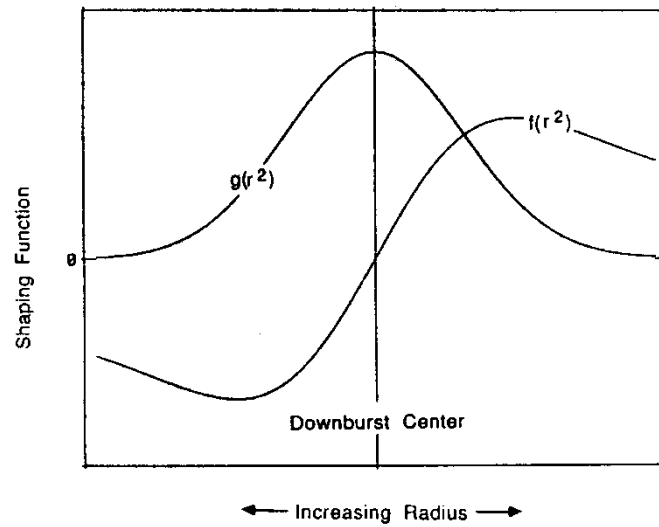

Figure 4 — Characteristic Variation of Horizontal Shaping Functions

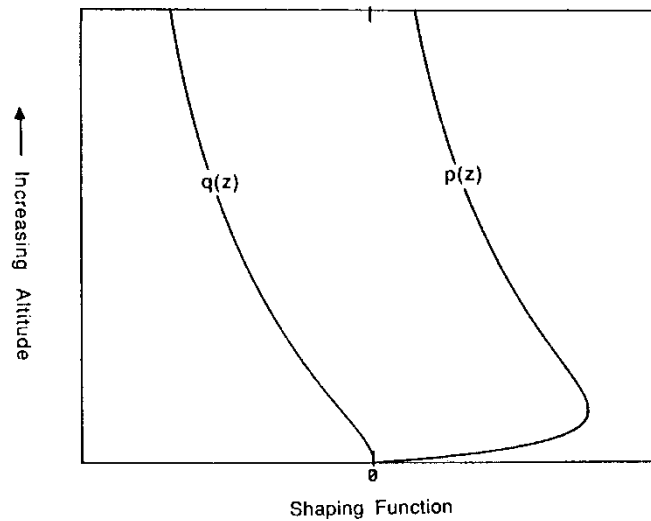

Figure 5 — Characteristic Variation of Vertical Shaping Functions

Combining the functions as in equation 3, the horizontal and vertical velocities are expressed as

$$u = \frac{\lambda R^2}{2r} [1 - e^{-(r/R)^2}] (e^{-z/z^*} - e^{-z/\varepsilon}) \quad (5)$$

$$w = -\lambda e^{-(r/R)^2} [\varepsilon (e^{-z/\varepsilon} - 1) - z^* (e^{-z/z^*} - 1)] \quad (6)$$

By taking derivatives of equations 5 and 6 with respect to r and z , respectively, and substituting in equation 2, it can be shown that the velocity distributions satisfy continuity.

The parameters z^* and ε were defined as characteristic scale lengths associated with ‘out of boundary layer’ and ‘in boundary layer’ behaviour, respectively. Analysis of TASS data indicated that $z^* = z_{m2}$, the altitude at which the magnitude of the horizontal velocity is half the maximum value.

It was also noted that the ratio

$$\frac{z_m}{z^*} = 0.22$$

To determine the location of the maximum horizontal velocity, the partial derivatives of u with respect to r and z were set equal to zero. The resulting equation for the r -derivative is

$$2 \left(\frac{r}{R} \right)^2 = e^{-(r/R)^2} - 1$$

The resulting equation for the z -derivative is

$$\frac{z_m}{z^*} = \frac{1}{(z^*/\varepsilon) - 1} \ln(z^*/\varepsilon)$$

Recalling that $z_m/z^* = 0.22$, the values 1.1212 and 12.5 were obtained from iteration for the ratios r/R and z^*/ε , respectively.

Using these values, the maximum horizontal velocity can be expressed as $u_{max} = 0.2357 \lambda R$. The maximum vertical wind is located at $r = 0$ and $z = z_h$, by definition, and is given by

$$W_{max} = \lambda z^* (e^{-(z_h/z^*)} - 0.92)$$

A ratio of maximum outflow and downflow velocities can be formed

$$\frac{u_m}{w_m} = \frac{0.2357R}{z^* (e^{-(z_h/z^*)} - 0.92)}$$

The Scaling factor, λ , was determined by using either of equations 5 or 6 for horizontal or vertical velocity, and setting it equal to the maximum velocity, u_{max} or w_{max} , respectively. Solving for λ results in:

$$\lambda = \frac{w_m}{z^* (e^{-(z_h/z^*)} - 0.92)} = \frac{u_m}{0.2357R}$$

The velocity equations were easily converted to rectangular coordinates, as shown in the Appendix. Partial derivatives with respect to x , y , and z were obtained by differentiating the velocity equations, and are also listed in this Appendix.

DISCUSSION AND RESULTS

Vertical and horizontal velocity profiles for u and w are shown in Figures 6 and 7.

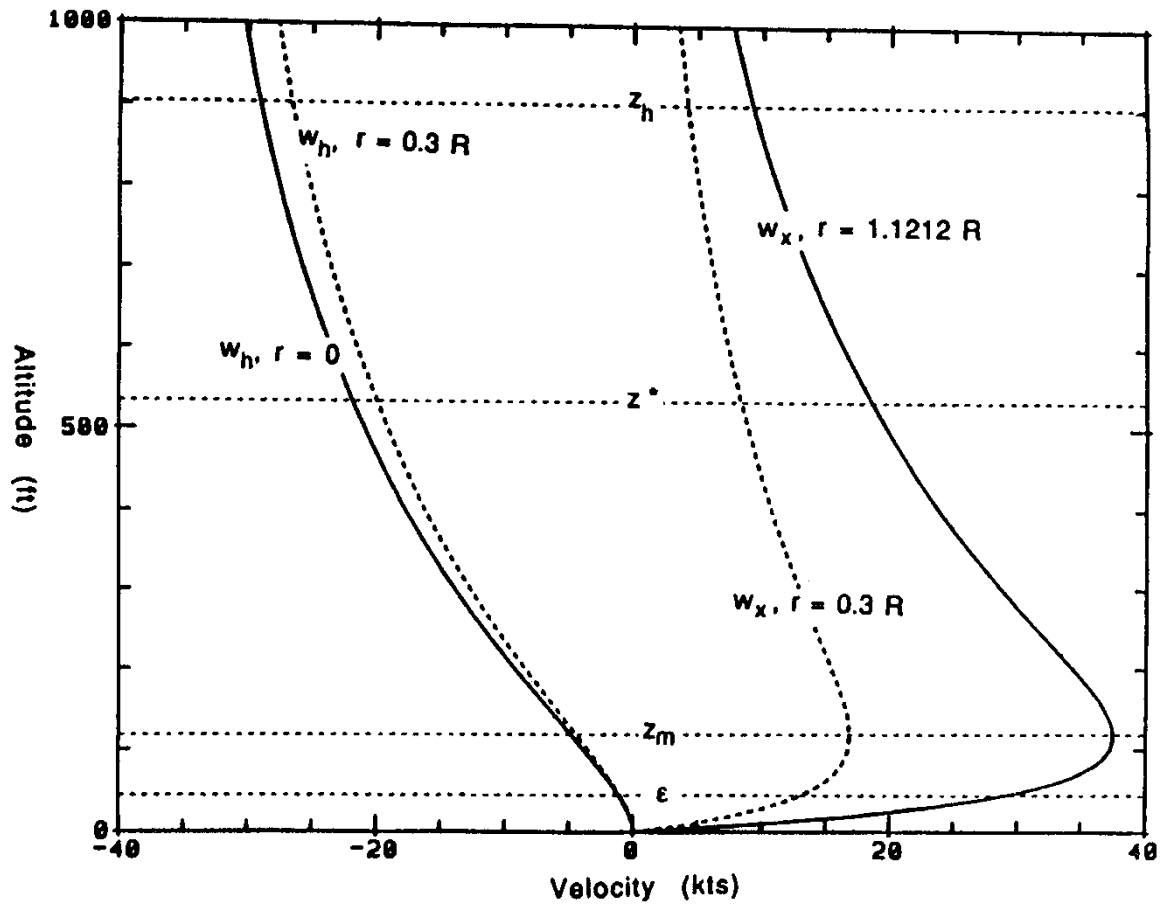

Figure 6 — Vertical Velocity Profiles for the Analytical Model

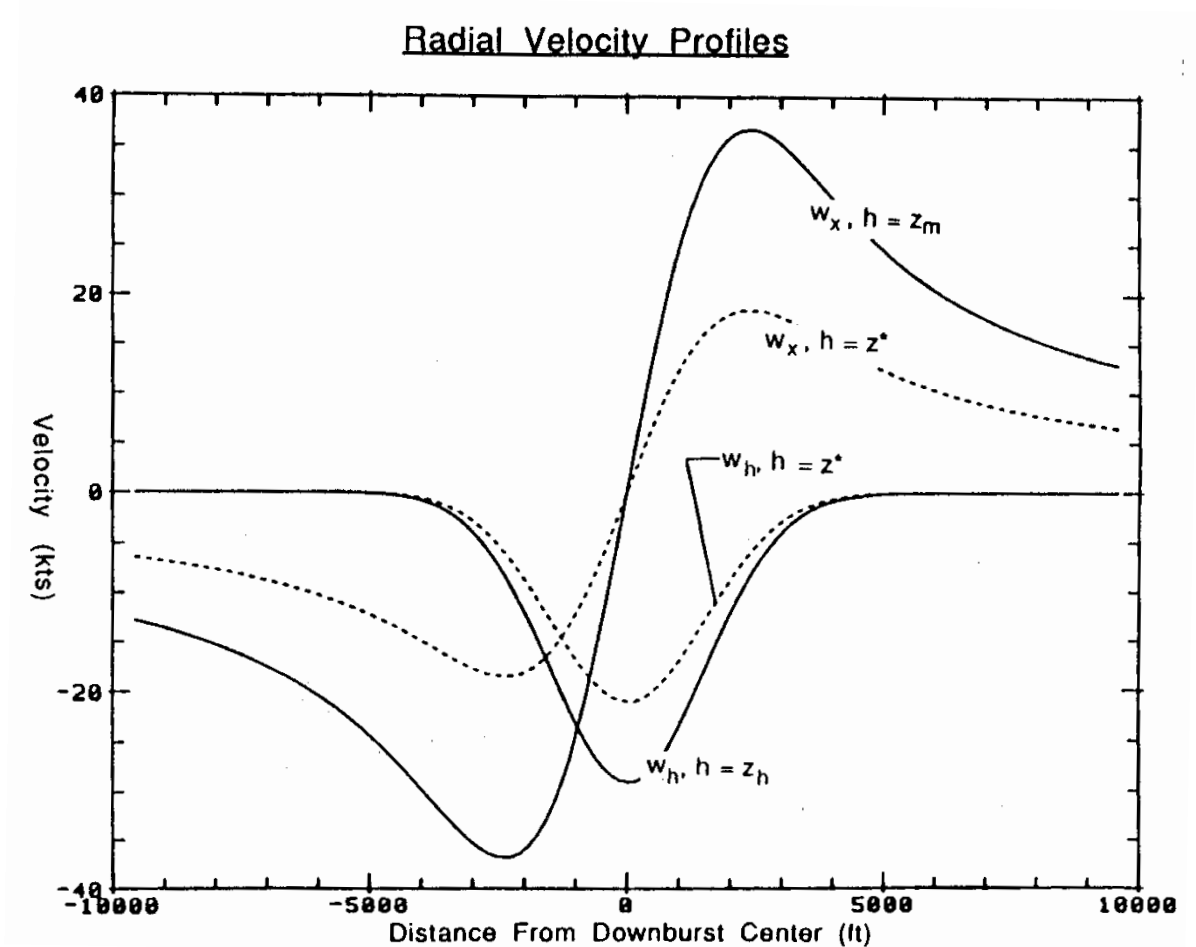

Figure 7 — Radial Velocity Profiles for the Analytical Model

Four profiles are shown for each component. The horizontal wind profiles in figure 6 were taken at the radii of peak outflow ($r = 1.1212 R$) and at about one-fourth that radius ($r = 0.3 R$), where the maximum outflow is approximately half the value at the peak outflow radius. The vertical wind profiles were taken at the radius of peak downflow ($r = 0$) and at $r = 0.3 R$. Horizontal wind and vertical wind profiles in figure 7 were taken at altitudes of $h = z_m$ (maximum outflow), $h = z^*$ (half-maximum outflow), and $h = z_h$ (depth of outflow).

This analytical model is compared with TASS, laboratory, and NIMROD data in figure 8. The figure shows that, when non-dimensionalised by the altitude of half-maximum outflow (z^*) and by the maximum outflow ($u = u_{max}$), the analytical model agrees closely with the other data.

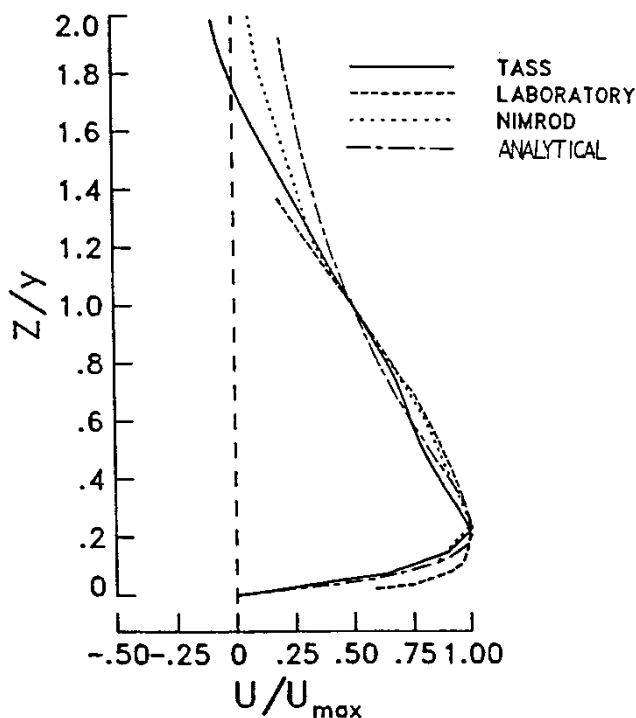

Figure 8 — Comparison of Wind Model Vertical Profiles

Different shears can be modelled by specifying four parameters, and the location of the downburst centre relative to the aeroplane flying through it. The four parameters are: 1) a characteristic horizontal dimension; 2) the maximum wind velocity; 3) the altitude of maximum outflow; and 4) the depth of outflow. The characteristic horizontal dimension specified is the radius of the downdraft column, noting that this is about 89 % of the radius of the peak outflow. The maximum wind velocity can be either horizontal or vertical.

CONCLUDING REMARKS

The analytic microburst model developed for use in real-time and batch simulation studies was shown to agree well with real-world measurements for the cases studied. The functions chosen for the model showed boundary-layer effects near the ground, as well as the peak and decay of outflow at increasing altitudes, and increasing downflow with altitude. The exponential increase and decay of the downflow and outflow (in the radial direction) are also characterised by the model. Equations for horizontal and vertical winds are simple and continuously differentiable, and partial derivatives in rectangular or cylindrical coordinates can be easily obtained by direct differentiation of the velocity equations. The governing equation for this system is the mass conservation law, and the analytic velocity functions developed here satisfied this condition. The model is sustained by a strong physical basis and yields high fidelity results, within the limitations of maintaining simplicity in the model, and variability of the microburst phenomenon. Parameterization of some of the characteristic dimensions allows flexibility in selecting the size and intensity of the microburst.

REFERENCES

- 1 Oseguera, M. and Bowles R. L.: A Simple, Analytic 3-Dimensional Downburst Model Based on Boundary Layer Stagnation Flow, Rosa, July 1988.
- 2 Bray, R. S.: Application of Data to Piloted Simulations. Wind Shear/Turbulence Inputs To Flight Simulation and Systems Certification, NASA CP-2474, 1987, pp. 97-115.

- 3 Hinton, D. A.: Aircraft Trajectory Guidance During Wind Shear Encounters. Master's Thesis, George Washington University, January 1988.
- 4 Hinton, D.A.: Flight management strategies for escape from microburst encounters, NASA TR 4057, 29, pp. 1988.
- 5 Hinton, D.A.: Relative merits of reactive and forward-look detection for wind shear encounters during landing approach for various microburst escape strategies, NASA TM-4158, DOT/FAA/DS-89/35, 1990.
- 6 Proctor, F.H.: The Terminal Area Simulation System, Volume I: Theoretical Formulation, NASA Contractor Report 4046, April 1987.
- 7 Proctor, F. H.: Numerical simulations of an isolated microburst. Part I: Dynamics and structure, J. Atmos. Sci., 45, pp. 3137-3160, 1988.
- 8 Proctor, F.H.: The Terminal Area Simulation System, Volume II: Verification Cases. NASA Contractor Report 4047, April 1987.
- 9 Proctor, F. H., 1989: Numerical simulations of an isolated microburst. Part II: Sensitivity experiments, J. Atmos. Sci., 46, pp. 2143-2165.
- 10 Frost, W.: Modeling and Implementation of Wind Shear Data. Wind Shear/ Turbulence Inputs to Flight Simulation and Systems Verification, NASA CP-2474, 1987, pp. 49-66.
- 11 Proctor, F. H.: NASA Wind Shear Model -- Summary of Model Analysis. Airborne Wind Shear Detection and Warning Systems, NASA CP-10006, 1988, pp. 29-66.
- 12 Proctor, F. H., and Bowles, R. L.: Three-dimensional simulation of the Denver 11 July 1988 microburst-producing storm, Meteorol. and Atmos. Phys., 49, 1992, pp. 107-124.
- 13 Fujita, T. T.: Tornadoes and Downbursts in the Context of Generalized Planetary Scales. Journal of Atmospheric Sciences, vol. 38, no. 8, August 1981, pp. 1511-1534.
- 14 Oseguera, R. M.; Bowles, R. L.; and Robinson, P. A., 1992: Airborne In Situ Computation of the Wind Shear Hazard Index, AIAA Paper 92-0291, 1992.
- 15 Lewis M. S., Robinson P. A., Hinton D. A., Bowles R. L.: The relationship of an integral wind shear hazard to aircraft performance limitations, NASA TM-109080, 1994.
- 16 Arbuckle, P. D., Lewis M. S., Hinton D. A.: Airborne systems technology application to the windshear threat, 20th Congress of the International Council of the Aeronautical Sciences, ICAS Paper No. 96-5.7.1, pp. 1640-1650, 1996.
- 17 Airborne Windshear Detection and Warning Systems. First Combined Manufacturers' and Technologists' Conference, NASA CP-10006, DOT/FAA/PS-88/7, 1988.
- 18 Airborne Windshear Detection and Warning Systems, Second Combined Manufacturers' and Technologists' Conference, NASA CP-10050, 1990.
- 19 Airborne Windshear Detection and Warning Systems, Third Combined Manufacturers' and Technologists' Conference, NASA CP-10060, DOT/FAA/RD-91/2-1, 1991.
- 20 Airborne Windshear Detection and Warning Systems, Fourth Combined Manufacturers' and Technologists' Conference, NASA CP-10105, DOT/FAA/RD-92/19-1, 1992.
- 21 Airborne Windshear Detection and Warning Systems, Fifth and Final Combined Manufacturers' and Technologists' Conference, NASA CP-10139, DOT/FAA/RD-94/14-1, 1994.

[Amdt ETSO/16]

Appendix 3 to ETSO-C117b – Wind Field Model Coordinate System Transformation

ED Decision 2020/011/R

This Appendix describes the conversion of the velocity equations in Appendix 2 to rectangular coordinates.

Define intermediate variables to simplify written equations:

$$\begin{aligned} e_r &= e^{-(r/R)^2} & e_d &= e_z - e_e \\ e_e &= e^{-(h/\varepsilon)} & e_c &= z^*(1 - e_z) - \varepsilon(1 - e_e) \\ e_z &= e^{-(h/z^*)} \end{aligned}$$

Horizontal and Vertical Velocities

$$W_x = \frac{\lambda R^2}{2r^2} (1 - e_r) e_d x_{ad}$$

$$W_y = \frac{\lambda R^2}{2r^2} (1 - e_r) e_d y_{ad}$$

$$W_h = -\lambda e_r e_c$$

Partial Derivatives

$$\frac{\partial w_x}{\partial x} = \frac{\lambda R^2 e_d}{2r^2} \left[e_r \left(\frac{2x_{ad}^2}{R^2} + \frac{2x_{ad}^2}{r^2} - 1 \right) - \frac{2x_{ad}^2}{r^2} + 1 \right]$$

$$\frac{\partial w_x}{\partial y} = \frac{\lambda R^2 x_{ad} y_{ad} e_d}{r^2} \left[e_r \left(\frac{1}{R^2} + \frac{1}{r^2} \right) - \frac{1}{r^2} \right]$$

$$\frac{\partial w_x}{\partial h} = \frac{\lambda R^2 x_{ad}}{2r^2} (1 - e_r) \left[\frac{e_e}{\varepsilon} - \frac{e_z}{z^*} \right]$$

$$\frac{\partial w_y}{\partial x} = \frac{\lambda R^2 x_{ad} y_{ad} e_d}{r^2} \left[e_r \left(\frac{1}{R^2} + \frac{1}{r^2} \right) - \frac{1}{r^2} \right]$$

$$\frac{\partial w_y}{\partial y} = \frac{\lambda R^2 e_d}{2r^2} \left[e_r \left(\frac{2y_{ad}^2}{R^2} + \frac{2y_{ad}^2}{r^2} - 1 \right) - \frac{2y_{ad}^2}{r^2} + 1 \right]$$

$$\frac{\partial w_y}{\partial h} = \frac{\lambda R^2 y_{ad}}{2r^2} (1 - e_r) \left[\frac{e_e}{\varepsilon} - \frac{e_z}{z^*} \right]$$

$$\frac{\partial w_h}{\partial x} = \frac{2\lambda x_{ad} e_r e_c}{R^2}$$

$$\frac{\partial w_h}{\partial y} = \frac{2\lambda y_{ad} e_r e_c}{R^2}$$

$$\frac{\partial w_h}{\partial h} = -\lambda e_r e_d$$

Other Relationships

From TASS $\frac{z_m}{z^*} = 0.22$ $\frac{z^*}{\varepsilon} = 12.5$

Maximums $W_{x_{max}} = 0.2357\lambda R$
 $W_{y_{max}} = W_{x_{max}}$
 $W_{h_{max}} = \lambda z^* (e^{-(z_h/z^*)} - 0.92)$

(λ is determined from the above relationships)

$$\frac{W_{x_{max}}}{W_{h_{max}}} = \frac{0.2357R}{z^* (e^{-(z_h/z^*)} - 0.92)}$$

Variable List

- z* = altitude where w_x is half the value of w_{x max} (ft)
- ε = characteristic height of boundary layer effects (ft)
- z_h = depth of outflow (ft)
- z_m = altitude of maximum outflow (ft)
- λ = scaling parameter (s⁻¹)
- r = radial distance from aeroplane to downburst (ft)
- h = altitude of aeroplane (ft)
- R = radius of downdraft (ft)
- x_{ad}, y_{ad} = x, y coordinates, aeroplane to microburst (ft)
- W_{x max}, W_{y max}, W_{h max} maximum winds, x, y, and h directions

[Amdt ETSO/16]

Appendix 4 to ETSO-C117b – Dryden Turbulence and Discrete Gust Model

ED Decision 2020/011/R

This Appendix contains data that defines the Dryden turbulence and discrete gust model to be used in conducting the tests specified in paragraphs 4(d)(7)(ii), 4(d)(7)(iii), 4(d)(8)(ii), and 4(d)(8)(iii) of Appendix 1 to this ETSO.

Dryden Turbulence Model

$$F_u(S) = \text{SIGMA}_u * \text{SQRT}(\text{TAU}_u/\text{PI}) * 1/(1 + \text{TAU}_u*S)$$

$$F_v(S) = \text{SIGMA}_v * \text{SQRT}\left(\frac{\text{TAU}_v}{\text{PI}^2}\right) * \frac{(1 + \text{SQRT}3*\text{TAU}_v*S)}{(1 + \text{TAU}_v*S)*(1 + \text{TAU}_v*S)}$$

$$F_w(S) = \text{SIGMA}_w * \text{SQRT}\left(\frac{\text{TAU}_w}{\text{PI}^2}\right) * \frac{(1 + \text{SQRT}3*\text{TAU}_w*S)}{(1 + \text{TAU}_w*S)*(1 + \text{TAU}_w*S)}$$

where:

SIGMA_u, SIGMA_v, SIGMA_w are the RMS intensities;

TAU_u = L_u/VA;

TAU_v = L_v/VA;

TAU_w = L_w/VA;

L_u, L_v, L_w are the turbulence scale lengths; VA is the aircraft’s true airspeed (ft/sec);

PI = 3.1415926535;

PI² = 6.2831853070 (2 times PI);

SQRT3 = 1.732050808 (square root of 3); and

S is the Laplace transform variable.

The following table lists SIGMA_u, SIGMA_v, SIGMA_w, L_u, L_v, and L_w versus altitude. Extrapolation will not be used, and simulator altitudes outside the bounds of the turbulence list will use the data at the boundary.

Altitude (feet)	RMS Intensities (ft/sec)			Scale Lengths (feet)		
	Long	Lat	Vert	Long	Lat	Vert
100	5.6	5.6	3.5	260	260	100
300	5.15	5.15	3.85	540	540	300
700	5.0	5.0	4.3	950	950	700
900	5.0	5.0	4.45	1123	1123	900
1500	4.85	4.85	4.7	1579	1579	1500

The applicant shall demonstrate that the variance of their turbulence implementation is adequate.

Discrete Gust Rejection

Discrete gusts (in the horizontal axis) with ranges of amplitude and frequency (A and OMEGA) of the form [A(1 – cos OMEGAt)] shall be used.

The following table lists the values of A and OMEGA to be used (this simulates an approximate 15-knot gust condition):

A	OMEGA (rad/sec)	Approx. Gust Duration (sec)
7.5	2.10	3
7.5	1.26	5
7.5	0.78	8
7.5	0.63	10
7.5	0.52	12
7.5	0.42	15
7.5	0.31	20

[Amdt ETSO/16]

Appendix 5 to ETSO-C117b – Shear Intensity

ED Decision 2020/011/R

$$f(t) = \frac{\dot{W}_x}{g} - \frac{W_h}{V}$$

where

\dot{W}_x = Horizontal component of the wind rate of change expressed in g units (1.91 kt/s = 0.1 g) (positive for increasing headwind).

W_h = Vertical component of the wind vector w (ft/s) (positive for downdraft).

V = True airspeed (ft/s).

g = Gravitational acceleration (ft/sec²).

[Amdt ETSO/16]

Appendix 6 to ETSO-C117b – Wind Shear Simulation Model

ED Decision 2020/011/R

The following computer listing (written in QuickBasic) provides a simplified aircraft simulation model for evaluating the effectiveness of various guidance schemes. This simulation runs on a personal computer, and the results obtained using it have been found to be comparable to those obtained on a full six-degrees-of-freedom simulator. This model was developed by J. Rene Barrios of the Honeywell Company.

The Wind Shear Simulation Model (WSSM) is a point mass three-degrees-of-freedom mathematical model which simulates the motion of an aeroplane in a vertical plane. The equations of motion, which are described in the wind axes, include the wind components of velocity and acceleration so that the aeroplane dynamics during a wind shear encounter are accurately modelled. This model has been used by several investigators to study the behaviour of an aeroplane during wind shear encounters.

Note: The Wind Shear Simulation Model provided at the end of this Appendix is an example written in Microsoft QuickBasic. Other programming languages such as Microsoft FORTRAN, C, or assembly language are also acceptable.

The Equations of Motion

The motion of a constant mass point in the vertical plane may be described by four equations of state and a control variable. For an aeroplane, it is convenient to use an orthogonal reference frame which is attached to the frame of the aeroplane, and its x-direction points in the direction of motion. Such a reference frame is the relative wind reference frame.

The following equations model the states of the aeroplane in the wind axes:

$$Vdt = g[(T.csal\alpha) - D]/W - sngam] - Wxdt.csgam - Wzdt.sngam \quad (1)$$

$$Gdt = \{g[(T.sn\alpha + L)/W - csgam] + Wxdt.sngam - Wzdt.csgam\}/V \quad (2)$$

$$Hdt = V.sngam + Wz \quad (3)$$

$$Xdt = V.csgam + Wx \quad (4)$$

where:

Vdt	Rate of change of true airspeed in knots/second
G	Gravitational constant in knots/second
T	Total engine thrust in lb
csalf	cos (alpha)
alpha	Angle of attack in radians
D	Total drag in lb.
W	Gross weight in lb
sngam	sin (gamma)
gamma	Flight path angle in radians
Wxdt	Inertial wind shear x-component in knots/second
Gdt	Rate of change of gamma in rad/second
snalf	sin (alpha)
L	Total lift in lb

V	True airspeed in knots
Hdt	Altitude rate in knots
Wz	Inertial wind z-component in knots
Xdt	Ground speed in knots

In the above equations, the positive directions are upwards and forwards. This implies that tailwinds and updrafts are positive, while headwinds and downdrafts are negative. All the states can be determined from a given alpha; therefore, alpha is the control variable.

Since the model is that of a point mass, it is necessary to introduce the concept of alpha_command and actual alpha to account for the effect of the horizontal tail/elevator. This is done by introducing a lag between the alpha_command and the actual alpha. Therefore, any command that is given to the elevator or stabiliser can be interpreted as an alpha_command, which will cause a change in the angle of attack.

From equations 1, 2, 3 and 4, it can be seen that any change in alpha will produce a change in the longitudinal and normal accelerations, which in turn will change the states of the aeroplane.

The Path Control Function

The different segments of the trajectory flown by the WSSM are described by a series of alpha_commands, which are generated by the procedure explained below.

1. The aeroplane is trimmed for the initial conditions specified by the user. The initial conditions are usually specified as the altitude, gross weight, flaps, speed, flight path angle, and wind characteristics. The trimming operation consists in finding the angle of attack that satisfies the equations of state and will result in an unaccelerated motion.
2. After the initial trim, alpha_command must be specified for each segment of the trajectory, which usually consists of a climb or descent segment at constant speed or constant path angle, and guidance through wind disturbances. The wind disturbance is provided by wind models that can be selected at initialisation time.
3. In order to specify an alpha_command, the user must supply a subroutine where a quadratic function is defined in such a way that when minimised with respect to alpha, and constrained by the equations of state, the minimising alpha will produce the desired path in an optimal manner. For example, if we want to fly initially at a constant path angle, say 8 degrees, then the quadratic function may be defined by the expression:

$$- \text{cst} = \left(\text{gamma} + \text{Gdt} * \text{dt} - \frac{8}{57.3} \right)^2 \tag{5}$$

where:

- cst Function to be minimised w.r.t alpha
- dt Time increment used in simulation in sec.
- Gdt*dt A predictive term which anticipates the change in gamma

Other expressions follow:

$$\text{cst} = (V + \text{Vdt} * \text{dt} - V_{\text{cmd}})^2 \qquad \text{Constant speed}$$

$$\text{cst} = (\text{alpha} + \text{gamma} + \text{Gdt} * \text{dt} - \text{pitch_cmd})^2 \qquad \text{Constant Pitch}$$

The minimisation of the function cst is performed by a subroutine at each time frame and is totally transparent to the user, who has to supply only the objective function cst.

4. Each expression defining a different value of the objective function *cst* is called a 'LAW'. The user selects the guidance law to be used during the wind shear encounter at the time the menu is displayed. This method allows the user to compare different guidance laws under the exact same conditions.

The Wind Models

The WSSM has two types of wind models: the Dallas-Ft Worth accident wind field, simulated by a *quad_vortex* model, and the constant shear model, which is user defined via the initial conditions menu.

Plotting Capabilities

The WSSM can plot up to 3 runs with 10 parameters per run. The length of each run should be kept under 60 seconds. This feature allows the user to compare different trajectories by overlaying the results.

The Programme

The WSSM is written in Microsoft QuickBasic, which is a highly structured language with a very friendly full-page editor. QuickBasic is very convenient for development, since it allows the user to stop execution, change the programme and continue executing. It also interfaces with Microsoft FORTRAN, C, or assembly language.

The procedure suggested for this application is that the WSSM be compiled without subroutines DETECT and GUIDE. DETECT and GUIDE can be separately compiled and put in a library called WNDSHR.QLB. These external subroutines may be written in Microsoft FORTRAN, C, or assembly language.

Listing of Programme

```
***** AIRCRAFT FLIGHT PROFILE SIMULATION *****  
  
,  
,  
  
DECLARE SUB PLOT ()  
DECLARE SUB TAKEOFF ()  
DECLARE SUB EULER ()  
DECLARE SUB MCRBRST ()  
DECLARE SUB WINDS ()  
DECLARE SUB OPT ()  
DECLARE SUB MIN (DM, M2, C1, C2, C3, M)  
DECLARE SUB BEGIN ()  
DECLARE SUB VSHAKER ()  
DECLARE SUB COST ()  
DECLARE SUB LIMIT ()  
DECLARE SUB RATES ()  
DECLARE SUB THRUST ()  
DECLARE SUB ATMOS ()  
DECLARE SUB PRINTS ()  
DECLARE SUB DRAGS ()  
  
COMMON SHARED FLPS%, GEAR%, GEAR$, CL, CD, LIFT, DRAG, ALPHA  
COMMON SHARED SEC, ALT, DST, HDOT, ALF, GAM, GAMREF, GREF, G  
COMMON SHARED WSALERT%, WXO, WL, WX, WXDT, WZ, WZDT, DFW
```

COMMON SHARED WV, LC%, GM, GREFF, NOSAVE, GMO
COMMON SHARED DELTA, ISA, TO, SPDSND, VT, VC, MACH, A0, TAT, TAMF
COMMON SHARED THRST, EPR, TFCT, APPFLG%
COMMON SHARED SNGM, CSGM, CSAL, SNAL, VDOT, WG, GDOT, XDOT
COMMON SHARED AWX, AWZ, AU, AZ, VG, GRND, KF1, GMIN, KF2
COMMON SHARED ACMD, OLDALF, DT, HP, LP, ALFLIM
COMMON SHARED LAW%, GMR, ASS, CST, VTO, GCMD
COMMON SHARED OUTFILES, DM, ALT1, PLS, TTT, WXDTO, TDX, TSH, WZO, TDZ, TSV
COMMON SHARED GM1, VTP, THETA
COMMON SHARED ALFRTE, PLMFLG%

' MAIN PROGRAM *'

START: '< -----<< RE-RUNS START HERE

CLOSE : CLEAR

COLOR 15, 1: CLS : VIEW PRINT

LOCATE 8, 23: PRINT "WINDSHEAR SIMULATION"

LOCATE 10, 23: PRINT "FOR "

LOCATE 12, 23: PRINT "BOEING 737/200 "

LOCATE 23, 23: PRINT "TYPE " + CHR\$(&H22) + "I" + CHR\$(&H22) + " FOR INFORMATION"

DO WHILE a\$ = ""

a\$ = INKEY\$

LOOP

IF a\$ = "I" OR a\$ = "i" THEN

a\$ = "": CLS

'----- INFORMATION PAGE-----'

LOCATE 2, 2: PRINT "BOEING 737/200 INFORMATON"

LOCATE 3, 2: PRINT "JT8D-17 ENGINES"

LOCATE 5, 2: PRINT "-----"

LOCATE 7, 2: PRINT "ALLOWABLE WEIGHT RANGES.....: 75,000 TO 120,000 POUNDS"

LOCATE 9, 2: PRINT "ALLOWABLE TAKEOFF FLAP SETTINGS.....: 1, 2, 5, 15, 20, 25 DEGREES"

LOCATE 11, 2: PRINT "ALLOWABLE LANDING FLAP SETTINGS.....: 30, 40 DEGREES"

LOCATE 13, 2: PRINT "TAKEOFF EPR AT SEA LEVEL, STD. DAY...: 2.1 "

LOCATE 15, 2: PRINT "REFERENCE WING AREA.....: 980 SQUARE FEET"

LOCATE 17, 2: PRINT "REFERENCE TAKEOFF SPEED.....: V2 + 10"

LOCATE 19, 2: PRINT "REFERENCE LANDING SPEED.....: 1.3 Vs"

LOCATE 23, 2: PRINT "Press Any Key to Continue..."

DO: LOOP WHILE INKEY\$ = ""

END IF

ANSS = "2"

CLS

WHILE (ANSS = "2")

LOCATE 10, 30: PRINT "Fly 1"

LOCATE 12, 30: PRINT "Plot 2"

LOCATE 14, 30: PRINT "Exit 3"

```
LOCATE 18, 30: INPUT "Selection ....."; ANSS
IF ANSS = "2" THEN
CALL PLOT
COLOR 15, 1
CLS
END IF
WEND

IF ANSS = "3" THEN END

CALL BEGIN 'GET DATA/INITIALIZE VARIABLES
CALL THRUST 'INITIALIZE THRUST
CALL TAKEOFF 'INITIALIZE TAKEOFF
CALL COST 'SUBROUTINE COST
CALL PRINTS 'SUBROUTINE PRINT
FOR ICL% = 1 TO TTT ' TTT IS THE RUN TIME IN SECONDS
CALL THRUST ' SUBROUTINE EPR/THRUST
CALL WINDS ' SUBROUTINE WINDS
' CALL DETECT ' SUBROUTINE WINDSHEAR DETECTION
' SUPPLIED BY USER
' MUST RESIDE IN LIBRARY WNDSHR.QLB
CALL OPT ' SUBROUTINE OPTIMIZE
CALL LIMIT ' SUBROUTINE ALPHA RATE
CALL EULER ' SUBROUTINE INTEGRATE
CALL ATMOS ' SUBROUTINE ATMOSPHERE
CALL PRINTS ' SUBROUTINE PRINT
IF ALT < 0 THEN EXIT FOR
NEXT ICL%
PRINT "RUN IS COMPLETE"
PRINT "TYPE " + CHR$(&H22) + "D" + CHR$(&H22) + " FOR RUN DATA"
a$ = ""
DO WHILE a$ = "" ' Wait for key to be pressed
a$ = INKEY$
LOOP
VIEW PRINT: COLOR 15, 4: CLS
IF a$ = "D" OR a$ = "d" THEN
a$ = ""
LOCATE 2, 2: PRINT "DATA FROM CURRENT RUN"
LOCATE 4, 2: PRINT "-----"
LOCATE 6, 2: PRINT "GROSS WEIGHT: "; WG; " POUNDS"
LOCATE 7, 2: PRINT "ISA DEVIATION: "; ISA; " DEG C"
LOCATE 8, 2: PRINT "FLAP POSITION: "; FLPS%; " DEGREES"
LOCATE 9, 2: PRINT "GEAR POSITION: "; GEAR$
LOCATE 11, 2: PRINT "CONTROL LAW: "; LAW%
LOCATE 12, 2: PRINT "GAMMA REFERENCE: "; GAMREF
LOCATE 13, 2: PRINT "PITCH LIMITING: "; PLS
IF PLS = "YES" THEN
```

```

LOCATE 14, 2: PRINT "MAXIMUM PITCH: "; HP * 57.3; " DEGREES"
LOCATE 15, 2: PRINT "MINIMUM PITCH: "; LP * 57.3; " DEGREES"
END IF
LOCATE 16, 2: PRINT "TIME OF RUN: "; TTT * DT; " SECONDS"
IF DFW = 1 THEN
LOCATE 17, 2: PRINT "DALLAS/FW Wind Model"
ELSE
LOCATE 17, 2: PRINT "HORIZ. WIND MAGNITUDE "; WXO; " KNOTS"
LOCATE 18, 2: PRINT "HORIZ. SHEAR MAGNITUDE: "; WXDTO; " KNOTS/SECOND"
LOCATE 19, 2: PRINT "HORIZ. SHEAR DURATION: "; TDX; " SECONDS"
LOCATE 20, 2: PRINT "VERT. WIND MAGNITUDE: "; WZO * 1.689; " FT/SECOND"
LOCATE 21, 2: PRINT "VERT. WIND DURATION: "; TDZ; " SECONDS"
LOCATE 22, 2: PRINT "-----"
END IF
IF LEN(OUTFILE$) = 0 THEN OUTFILE$ = "NONE"
LOCATE 23, 2: PRINT "OUTPUT FILE: "; OUTFILE$
LOCATE 24, 2: PRINT "Press Any Key to Continue..."
DO: LOOP WHILE INKEY$ = "" 'Wait for key to be pressed
END IF
GOTO START
END
SUB ATMOS STATIC
*****
' SUBROUTINE ATMOSPHERE *
*****
STATIC THETA
L% = ALT > 36089!
FISA = 1.8 * ISA
IF ALT > 36089 THEN
TMP = .7519 * T0
DELTA = .2234 * EXP((36089! - ALT) / 20806)
ELSE
TMP = T0 - .0035662 * ALT
DELTA = (TMP / T0) ^ 5.256
END IF
TAMB = TMP + FISA 'TAMBient in deg. R
TAMF = TAMB - 459.7 ' " " F
THETA = TAMB / T0
SQRTH = SQR(THETA)
SPDSND = A0 * SQRTH
IF VT > 0 THEN MACH = VT / SPDSND
VC = A0 * SQR(5 * (((1 + MACH * MACH / 5) ^ 3.5 - 1) * DELTA + 1) ^ .28571 - 5)
TAX = (TMP + FISA) * (1 + .2 * MACH * MACH) 'Deg. R
TAT = 5 * (TAX - 459.7 - 32) / 9 'Deg. C
IF INKEY$ <> "" THEN PRINT : INPUT "Press ENTER to continue...."; XXX

```

```
END SUB
SUB BEGIN STATIC
CLS : VIEW PRINT
'<----- DATA_INPUT ----->
PRINT
INPUT "OUTPUT FILE (DEFAULT IS NO FILE) "; OUTFILES
IF OUTFILES$ = " " THEN
NOSAVE = 1
ELSE
NOSAVE = 0
END IF
' CONSTANTS USED IN CALCULATIONS:
A0 = 661.478599# 'Speed of sound at sea level in knots
G = 19.07583 'Gravitational constant in knots/sec
T0 = 518.67 'Standard temperature at SL in deg Rankine
DT = .25 'Simulation time step in seconds
'----- INITIALIZATION OF VARIABLES-----
GMIN = 0
VDOT = 0
ALT1 = 0
INPUT "TAKEOFF OR APPROACH (T/A) (Default is T)....."; ANSS
IF ANSS$ = "a" OR ANSS$ = "A" THEN
INPUT "ENTER ALTITUDE IN FEET (Default is 1000' . "; ALT1
IF ALT1 = 0 THEN ALT1 = 1000
APPFLG% = 1
TFCT = 1
END IF
ALT = ALT1
'----- CONFIGURATION CONSTANTS-----
ASS = 16.5 'Stick Shaker alpha in degrees
ASS = ASS / 57.3 ' " " "radians
'----- GROSS WEIGHT ENTRY-----
PRINT : INPUT "ENTER GROSS WEIGHT IN POUNDS (Default is 110000) "; WG
IF WG = 0 THEN WG = 110000! ' DEFAULT SETTING
FL% = 0
WHILE (NOT FL%)
INPUT "ENTER FLAPS SETTING (Default is 0)....."; FLPS%
SELECT CASE FLPS%
CASE 0, 1, 2, 5, 15, 20, 25, 30, 40
FL% = -1
CASE ELSE
FL% = 0
PRINT "Invalid flaps setting"
PRINT "Only 0, 1, 2, 5, 15, 20, 25, 30, & 40 are supported"
PRINT
```



```
END SELECT
WEND
IF FLPS% < 15 THEN GEAR% = 1
IF FLPS% = 15 THEN INPUT "GEAR UP OR DOWN (1 / 0) (Default is Down)....."; GEAR%
IF GEAR% = 1 THEN
GEARS$ = " UP"
ELSE
GEARS$ = " DOWN"
END IF
INPUT "ENTER ISA DEV. IN DEGREES C (Default is 0)....."; ISA
PRINT
CALL VSHAKER ' COMPUTE V2+10 FOR FLAPS<33 OR 1.3Vs FOR FLAPS>32
PRINT " CONTROL LAW SELECTION:"
PRINT
PRINT " Speed = 1.1 * V_stall = 1"
PRINT " Alpha = Stick Shaker Alpha = 2"
PRINT " Horizontal Acceleration = 0 = 3"
PRINT " 15_Degree Pitch = 4"
PRINT " Theoretical HONEYWELL/SPERRY = 5"
PRINT " User Defined = 6"
PRINT
INPUT " SELECT CONTROL LAW ..... "; LAW%
IF LAW% = 0 THEN LAW% = 5
PRINT : PRINT
' ----- GAMMA REFERENCE INPUT-----
IF LAW% > 4 THEN
INPUT "ENTER GAMMA REFERENCE IN DEGREES (Default is 0)....."; GMR
PRINT
GAMREF = GMR
GMR = GMR / 57.3: GMIN = GMR
END IF
' ----- PITCH LIMITING SELECTION-----
INPUT "PITCH LIMITING DESIRED (y/n) (Default is NO)....."; PLS
IF PLS = "Y" OR PLS = "y" THEN
PLS = "YES"
INPUT " MAXIMUM PITCH ALLOWED IN DEGREES "; HP
INPUT " MINIMUM PITCH ALLOWED IN DEGREES "; LP
HP = HP / 57.3: LP = LP / 57.3: PL% = 1
ELSE
HP = 100
LP = -100
PL% = 0
PLS = "NO"
END IF
CLS
```

```
'----- TIME FOR RUN-----
PRINT
INPUT "ENTER TIME OF RUN IN SECONDS (Default is 45)....."; TTT
TTT = TTT / DT
IF TTT = 0 THEN TTT = 45 / DT ' DEFAULT SETTING
'----- WINDSHEAR SET UP-----
INPUT "DALLAS/FW Wind Model (y/n)...(Default is constant Shear)...."; ANSS
IF ANSS = "Y" OR ANSS = "y" THEN
DFW = 1
ELSE
DFW = 0
PRINT
INPUT "MAGNITUED OF HORZ. WIND IN KNOTS.....(Head wind < 0)....."; WXO
INPUT "MAGNITUED OF HORZ. SHEAR IN KT/SEC. (Dec. Perf. > 0)....."; WXDTO
INPUT "DURATION OF HORZ. SHEAR IN SEC.....(Default is 0)....."; TDX
INPUT "TIME FOR SHEAR TO START IN SEC.....(Default is 0)....."; TSH
PRINT
INPUT "MAGNITUED OF VERT. WIND IN FT/SEC. (Down Draft < 0)....."; WZO
WZO = WZO / 1.689 'Convert to knots
INPUT "DURATION OF VERT. WIND IN SEC.....(Default is 0)....."; TDZ
INPUT "TIME FOR SHEAR TO START IN SEC.....(Default is 0)....."; TSV
PRINT
END IF
'----- OTHER SET UPS-----
VT = VTO
WX = WXO
CALL ATMOS ' SUBROUTINE ATMOSPHERE
'----- HEADERS FOR SCREEN DISPLAY-----
CLS : PRINT
PRINT "TIME ALT HDOT VT ALPHA GAMMA PITCH GREF WXDT WZ VDOT ALRT"
PRINT "(SEC) (FT) (FPM) (KTS) (DEG) (DEG) (DEG) (DEG) (KT/S) (FPS) (KT/S)"
PRINT STRING$(75, "-"): VIEW PRINT 5 TO 25
*****
' SUBROUTINE INIT_OUTPUT FILE *
*****
IF NOSAVE THEN ' CREATE OUTPUT FILE
ELSE
OPEN "O", 2, OUTFILES
FMT$ = " ###.## ##### ##### ##### ## ##.## ##.## ##.##"
FMT$ = FMT$ + " ###.## ##.## ##.## "
END IF
END SUB
SUB COST STATIC
*****
' SUBROUTINE COST *
```

```

*****
CALL DRAGS ' SUBROUTINE DRAG & LIFT
CALL RATES ' SUBROUTINE RATES
IF LC% = 0 THEN 'Constant gamma segment
FCT = (GM + GDOT * DT - GMO) ^ 2
GREFF = 57.3 * GMO
ELSE 'All guidance laws
SELECT CASE LAW%
CASE 1 ' ----- 1.1*Vstall-----
CST = (VT + VDOT * DT - 1.1 * 135) ^ 2
CASE 2 ' ----- Alpha = Ass-----
CST = (ALPHA - ASS) ^ 2
CASE 3 ' ----- Ax = 0-----
CST = (VDOT - VT * GDOT * GM + WXDT) ^ 2
CASE 4 ' ----- 15 Degrees-----
CST = (GM + 3 * GDOT * DT + ALPHA - 15 / 57.3) ^ 2
CASE 5 ' ----- User Defined-----
PRINT "Not defined"
STOP
CASE 6 ' ----- User Supplied-----
'User must supply a subroutine called GUIDE
'which must reside in the WNDSHR.QLB Library
'GUIDE can have a list of arguments
'As an example
'ALF = 57.3*ALPHA
'PTH = 57.3 * (ALPHA + GM)
' units : ft fpm kt deg g's *
'CALL GUIDE(ALT, HDOT, VC, ALF, PTH, AU, AZ, CST)
END SELECT
END IF
' CST is the Cost Function to be minimized
END SUB
SUB DRAGS STATIC
*****
' SUBROUTINE DRAG FOR B737/200 *
*****
X = 57.3 * ALPHA + 1
CF5 = 0: CF4 = 0: CF3 = 0: CF2 = 0
SELECT CASE FLPS%
CASE 0
CF1 = .091
CF0 = .0156
CASE 1
CF3 = -1.164058E-04
CF2 = 2.48561E-03

```

CF1 = .0905781

CF0 = .062114

CASE 2

CF0 = .101198

CF1 = .110993

CF2 = -.0015162

CF3 = 1.8931E-04

CF4 = -7.1427E-06

CF5 = -4.2776E-09

CASE 5

CF0 = .192638

CF1 = .123509

CF2 = -.0051477

CF3 = 6.4968E-04

CF4 = -3.0891E-05

CF5 = 4.1291E-07

CASE 10

CF0 = .249855

CF1 = .114005

CF2 = 7.1207E-04

CF3 = -9.9541E-05

CF4 = 7.0431E-06

CF5 = -2.3773E-07

CASE 15

CF0 = .40149

CF1 = .118723

CF2 = -6.4877E-04

CF3 = 6.6281E-05

CF4 = -1.6113E-07

CF5 = -1.4278E-07

CASE 25

CF0 = .592655

CF1 = .122433

CF2 = -.0026365

CF3 = 3.5963E-04

CF4 = -1.5579E-05

CF5 = 1.0894E-07

CASE 30

IF X < 4 THEN

CF1 = .12

CF0 = .72

ELSE

CF3 = -1.651192E-04

CF2 = 4.16461E-03

CF1 = 8.337061E-02

```
CF0 = .8350316
END IF
CASE 40
IF X < 4 THEN
CF1 = .12
CF0 = 1.08
ELSE
CF3 = -1.689903E-04
CF2 = 3.733285E-03
CF1 = 8.483822E-02
CF0 = 1.201596
END IF
CASE ELSE
PRINT "Flaps "; FLPS%; " not available....."
END
END SELECT 'For CL computation
CL = (((CF5 * X + CF4) * X + CF3) * X + CF2) * X + CF1) * X + CF0
SELECT CASE FLPS% 'Low Speed Drag Polars
CASE 0
D0 = .013285: D1 = .052868: D2 = -.07182: D3 = .071561
CASE 1
D0 = .026143: D1 = .022358: D2 = -.00083: D3 = .016338
CASE 2
D0 = .070346: D1 = -.0852: D2 = .097453: D3 = -.01207
CASE 5
D0 = .045214: D1 = -.0178: D2 = .04373: D3 = .002101
CASE 10
D0 = -.04266: D1 = .19643: D2 = -.1152: D3 = .03966
CASE 15
IF GEAR% = 0 THEN
D0 = .034954: D1 = .098892: D2 = -.04187: D3 = .020496
ELSE
D0 = -.02822: D1 = .174631: D2 = -.0874: D3 = .029566
END IF
CASE 25
D0 = -.10416: D1 = .327506: D2 = -.17059: D3 = .043313
CASE 30
D0 = .124697: D1 = -.03348: D2 = .055295: D3 = -.00311
CASE 40
D0 = .124925: D1 = .052537: D2 = .006912: D3 = .0058
CASE ELSE
PRINT "Flaps "; FLPS% " not available....."
END
END SELECT
CD = ((D3 * CL + D2) * CL + D1) * CL + D0
```

```

Q = 1451770 * MACH * MACH * DELTA 'B737/200
LIFT = Q * CL
DRAG = Q * CD
END SUB
SUB EULER STATIC
*****
' SUBROUTINE EULER'S PREDICTOR/CORRECTOR *
' (INTEGRATION SUBROUTINE) *
*****
DTH = DT / 3600: DTM = DT / 60: SEC = SEC + DT: VTP = VT
CALL RATES ' SUBROUTINE RATES <<PREDICTOR>>
ALT1 = ALT: HDOT1 = HDOT: ALT = ALT + HDOT * DTM
GM1 = GM: GDOT1 = GDOT: GM = GM + GDOT * DT
DST1 = DST: XDOT1 = XDOT: DST = DST + XDOT * DTH
VT1 = VT: VDOT1 = VDOT: VT = VT + VDOT * DT
CALL RATES ' SUBROUTINE RATES <<CORRECTOR>>
ALT = ALT1 + (HDOT1 + HDOT) * DTM / 2
GM = GM1 + (GDOT1 + GDOT) * DT / 2
DST = DST1 + (XDOT1 + XDOT) * DTH / 2
VT = VT1 + (VDOT1 + VDOT) * DT / 2
END SUB
SUB LIMIT STATIC
*****
' SUBROUTINE ALPHA DOT AND PITCH LIMIT *
*****
ALPHA = OLDALF + .25 * (ACMD - OLDALF) 'Pitch dynamics
CALL DRAGS ' SUBROUTINE DRAG (REQ'D FOR RATE SUB CALL)
IF PLMFLG% = 0 THEN EXIT SUB
OLDGM = GM
PLIM% = 0
DO WHILE (PLIM% = 0)
CALL RATES ' SUBROUTINE RATES
X = ALPHA + OLG + GDOT * DT
IF X > HP THEN ALPHA = .9 * ALPHA
IF X < LP THEN ALPHA = 1.1 * ALPHA
IF ALPHA > ALFLIM THEN
ALPHA = ALFLIM
PLIM% = 1
END IF
LOOP
END SUB
SUB MCRBRST STATIC
IF MU1 = 0 THEN
MU1 = -37141!
AV = 5500: H1 = 2500: G3 = 3: J1 = -700: J2 = 800: J3 = 6.5

```

```

MU2 = -20000
BV = 12000: H2 = 2000: N1 = 200: N2 = 2500: N3 = 4
WX = 5
IF ALT > 1000 THEN
PRINT
PRINT " DFW data not available above 1000"
PRINT " Please start at or below 1000"
END
END IF
END IF
X = 6078 * DST: Y = ALT: A1 = AV: A2 = BV
NX1 = Y - H1: DENX1 = (Y - H1) ^ 2 + (X - A1) ^ 2
NY1 = X + J2 - A1: DENY1 = (Y + J1 - H1) ^ 2 + (X + J2 - A1) ^ 2
NX2 = Y - H2: DENX2 = (Y - H2) ^ 2 + (X - A2) ^ 2
NY2 = X + N2 - A2: DENY2 = (Y + N1 - H2) ^ 2 + (X + N2 - A2) ^ 2
NX3 = Y + H1: DENX3 = (Y + H1) ^ 2 + (X - A1) ^ 2
NY3 = X + J2 - A1: DENY3 = (Y + J1 + H1) ^ 2 + (X + J2 - A1) ^ 2
NX4 = Y + H2: DENX4 = (Y + H2) ^ 2 + (X - A2) ^ 2
NY4 = X + N2 - A2: DENY4 = (Y + N1 + H2) ^ 2 + (X + N2 - A2) ^ 2
XX = MU1 * (-NX1 / DENX1 + NX3 / DENX3) + MU2 * (NX2 / DENX2 - NX4 / DENX4)
WX = WX + .65 * (XX - WX) + 2 * G3
IF DST = 0 THEN WXP = WX
ZZ = MU1 * (NY1 / DENY1 - NY3 / DENY3) * J3 + MU2 * (-NY2 / DENY2 + NY4 / DENY4) * N3
WZ = WZ + .65 * (ZZ - WZ)
IF DST = 0 THEN WZP = WZ
WX5 = WX4: WX4 = WX3: WX3 = WX2: WX2 = WX1: WX1 = WX
WZ5 = WZ4: WZ4 = WZ3: WZ3 = WZ2: WZ2 = WZ1: WZ1 = WZ
IF WCNT% < 4 THEN WXDT = (WX - WXP) / DT: WXP = WX
IF WCNT% < 4 THEN WZDT = (WZ - WZP) / DT: WZP = WZ
IF WCNT% > 3 THEN WXDT = (26 * WX5 - 27 * WX4 - 40 * WX3 - 13 * WX2 + 54 * WX1) / (70 * DT)
IF WCNT% > 3 THEN WZDT = (26 * WZ5 - 27 * WZ4 - 40 * WZ3 - 13 * WZ2 + 54 * WZ1) / (70 * DT)
IF ABS(WXDT) > 15 THEN WXDT = 15 * SGN(WXDT)
IF ABS(WZDT) > 15 THEN WZDT = 15 * SGN(WZDT)
WCNT% = WCNT% + 1
END SUB
SUB MIN (DM, M2, C1, C2, C3, M) STATIC
*****
'SUBROUTINE MIN_CST BY LEAST SQUARES PARABOLA *
*****
ALPHA = M2 + DM 'INCREMENT ALPHA
CALL COST 'SUBROUTINE COST
IF DM < 0 THEN
C4 = CST
ELSE
SWAP C1, C3

```

```

C5 = CST
END IF
ALPHA = M2 - DM 'DECREMENT ALPHA
CALL COST 'SUBROUTINE COST
IF DM < 0 THEN
C5 = CST
ELSE
C4 = CST
END IF
M = ABS(DM) * (14 * C1 + 7 * C4 - 7 * C5 - 14 * C3) / (20 * C1 - 10 * C4 - 20 * C2 - 10 * C5 + 20 * C3)
END SUB
SUB OPT STATIC
*****
'SUBROUTINE OPTALF - DETERMINES THE ALPHA REQD FOR CMD GAMMA *
*****
OLDALF = ALPHA: GM1 = GM
CALL ATMOS ' SUBROUTINE ATMOSPHERE
CALL RATES ' SUBROUTINE RATES
DM = 1 / 57.3 ' SET ALPHA INCREMENT TO 1 DEGREE
C1 = 1E+20
C2 = 1E+20
C3 = 1E+20
OPTFLG% = 0
WHILE (OPTFLG% = 0)
CALL COST ' SUBROUTINE COST
C3 = C2: C2 = C1: C1 = CST
M3 = M2: M2 = M1: M1 = ALPHA
LGC% = C1 > C2 AND C3 = 1E+20
IF LGC% THEN
DM = -DM ' Reverse search direction
C1 = C2: C2 = CST: M1 = M2: M2 = ALPHA
ALPHA = ALPHA + 2 * DM
ELSE
IF C1 < C2 THEN
L% = ABS(OLDALF - ALPHA) / DT > ALFRTE OR ALPHA > ALFLIM OR ALPHA < -.08
IF L% THEN OPTFLG% = 1
ALPHA = ALPHA + DM
ELSE
DM = DM / 2
CALL MIN(DM, M2, C1, C2, C3, M)'Fit parabola & find minimum
ALPHA = M2 + M 'This is the optimum alpha
OPTFLG% = 1 'Set flag to terminate
END IF
END IF
WEND

```



```
ALFLIM = ASS 'SET ALPHA LIMIT TO ALPHA STICK SHAKER
SELECT CASE LAW%
CASE 4
ALFLIM = ASS - .035 'LIMIT TO SS MINUS 2 DEG
CASE 5, 6
ALFLIM = ASS - KF2
CASE ELSE
END SELECT
IF ALPHA < -.08 THEN ALPHA = -.08
IF ALPHA > ALFLIM THEN ALPHA = ALFLIM
ACMD = ALPHA 'SET ALPHA COMMAND TO COMPUTED ALPHA
END SUB
SUB PLOT
*****
* PLOT ROUTINE *
*****
REM $DYNAMIC
' TWO DIMENSIONAL PLOTTER
DEFINT I-L, N
DIM F$(3) ' file name array
DIM DTA(3, 250, 15) ' data array
DIM TYS(14) ' title array (dependant variable)
TITLES$ = "HONEYWELL WINDSHEAR SIMULATION" ' main title
TX$ = "Time (s)" ' X title
TYS(1) = "Altitude ft "
TYS(2) = "Alt Rate fpm "
TYS(3) = "T A S kts "
TYS(4) = "Alpha deg "
TYS(5) = "Gamma deg "
TYS(6) = "Pitch deg "
TYS(7) = "G_ref deg "
TYS(8) = "Hz Shear kps "
TYS(9) = "Vt Wind fps "
TYS(10) = "Vt rate kps "
TYS(11) = "W/S Flag "
NV = 12
CLS
LOCATE 3, 15: PRINT "Enter the names of the data files you wish to plot."
FOR NC = 1 TO 3
LOCATE 6 + 2 * NC, 25 ' input
PRINT "FILENAME "; NC; " "; ' filenames
INPUT ; F$(NC) ' containing
IF F$(NC) = "" THEN EXIT FOR ' data
NEXT NC
NC = NC - 1 ' number of curves to plot
```

```
LOCATE 20, 15: PRINT "Reading from disk....."
FOR I = 1 TO NC
CLOSE
OPEN "I", #1, FS(I) ' open file for input
NP = 0
DO
NP = NP + 1 ' number of points
FOR J = 1 TO NV
INPUT #1, DTA(I, NP, J) ' read data
NEXT J
LOOP UNTIL EOF(1)
CLOSE
NEXT I
DO ' display all selected parameters
DO ' prompt user until a valid parameter is selected
100 CLS
LOCATE 3, 20: PRINT "Select the parameter you wish to plot."
FOR I = 1 TO NV - 1
LOCATE 4 + I, 30: PRINT TY$(I); " = "; I
NEXT I
LOCATE 21, 30: INPUT "parameter number (0 to exit)"; PARAM%
IF PARAM% = 0 THEN
CLS
EXIT SUB ' return to calling program
END IF
LOOP UNTIL 1 <= PARAM% AND PARAM% <= 14 'end of select loop
PARAM% = PARAM% + 1
DX = 5 ' x axis grid increment
GOSUB 400 ' find maximum x and y values
IF PLTFLG% = 1 THEN
PRINT "No information to plot...."
PRINT "Press any key to continue..."
DO: LOOP WHILE INKEY$ = ""
GOTO 100
END IF
GOSUB 600 ' grid and titles
FOR I = 1 TO NC
GOSUB 1110 ' plot graph
NEXT I
DO
LOOP WHILE INKEY$ = ""
CLS : SCREEN 0
LOOP
*****
400 '* MAX SUBROUTINE *
```

,

```
MAXX = DTA(1, 1, 1)
MAXY = DTA(1, 1, PARAM%)
MINY = DTA(1, 1, PARAM%)
FOR I = 1 TO NC
FOR J = 1 TO NP
IF DTA(I, J, 1) > MAXX THEN MAXX = DTA(I, J, 1)
IF DTA(I, J, PARAM%) > MAXY THEN MAXY = DTA(I, J, PARAM%)
IF DTA(I, J, PARAM%) < MINY THEN MINY = DTA(I, J, PARAM%)
NEXT J
NEXT I
PLTFLG% = 0
DY = (MAXY - MINY) / 15
IF DY = 0 THEN
PLTFLG% = 1
DY = 5
END IF
MAG = 10 ^ (INT(LOG(DY) / LOG(10))): DY = DY / MAG
IF DY <= 5 THEN
DY = 5
ELSE
DY = 10
END IF
DY = DY * MAG
IF INT(MAXX / DX) <> MAXX / DX THEN MAXX = INT(MAXX / DX + 1) * DX
IF INT(MAXY / DY) <> MAXY / DY THEN MAXY = INT(MAXY / DY + 1) * DY
IF INT(MINY / DY) <> MINY / DY THEN MINY = INT(MINY / DY) * DY
NUMX = MAXX / DX
NUMY = (MAXY - MINY) / DY
RETURN
600
```

* GRID AND TITLES *

,

```
CLS
SCREEN 2 ' 640*200 monochrome graphics
KEY OFF
FOR J = 0 TO NUMX
Z = J * 580 / NUMX + 59
LINE (Z, 10) - (Z, 170) ' vertical grid line
Z = J * 71 / NUMX + 7
a = DX * J
```

```
IF a < > 0 THEN ' adjustment for
D = INT(LOG(a) / LOG(10)) + 1 ' large numbers
IF D > 1 THEN Z = Z - D + 1
END IF
LOCATE 23, Z
PRINT a;
NEXT J
FOR J = 0 TO NUMY
Z = J * 160 / NUMY + 10
LINE (60, Z) - (640, Z) ' horizontal grid line
Z = 22 - J * 20 / NUMY
LOCATE Z, 2
Z = DY * J + MINY
AZ = ABS(Z)
IF INT(Z) = Z THEN
G$ = "#####"
ELSEIF AZ < .1 THEN
G$ = "#.####"
ELSEIF AZ >= .1 AND AZ < 1 THEN
G$ = "##.###"
ELSEIF AZ >= 1 AND AZ < 10 THEN
G$ = "###.##"
ELSEIF AZ >= 10 AND AZ < 100 THEN
G$ = "####.#"
ELSE
G$ = "#####"
END IF
PRINT USING G$; Z;
NEXT J
Z = (80 - LEN(TITLES)) / 2 + 2
LOCATE 1, Z: PRINT TITLES ' print main title
LOCATE 24, 36: PRINT TX$; ' X axis title
LOCATE 8, 1 ' Y
FOR J = 1 TO LEN(TY$(PARAM% - 1)) ' axis
PRINT MID$(TY$(PARAM% - 1), J, 1) ' title
NEXT J
LOCATE 25, 10: PRINT "1"; ' curve
LINE (90, 195) - (130, 195)
LOCATE 25, 20: PRINT "2"; ' labels
FOR J = 0 TO 40 STEP 8
XX = 170 + J
PSET (XX, 195)
CIRCLE (XX + 80, 195), 2
NEXT J
LOCATE 25, 30: PRINT "3";
```

RETURN

* PLOTTING ROUTINE *

,

1110 FOR J = 1 TO NP

XX = 580 * DTA(I, J, 1) / MAXX + 60' calculate pixel X position

YY = 170 - 160 * (DTA(I, J, PARAM%) - MINY) / (MAXY - MINY)

IF J = 1 THEN GOTO 1170

IF I = 1 THEN LINE (XXOLD, YYOLD) - (XX, YY) ' line 1170

1170 XXOLD = XX: YYOLD = YY

IF I = 2 THEN PSET (XX, YY) ' point

IF I = 3 THEN CIRCLE (XX, YY), 2 ' circle

NEXT J

RETURN

END SUB

REM \$STATIC

DEFSNG I-L, N

SUB PRINTS

' SUBROUTINE PRINT TO SCREEN AND FILE *

ACMDG = 57.3 * ACMD

ALF = 57.3 * ALPHA

GAM = 57.3 * GM

PITCH = ALF + GAM

WZX = 1.689 * WZ

IF NOSAVE = 0 THEN PRINT #2, SEC, ALT, HDOT, VT, ALF, GAM, PITCH, GREFF, WXDT, WZX, VDOT, WSALERT%

FMT1\$ = "###.## ##### ### ##.# ##.# ##.# ##.# ##.# ##.# ##.# ##.#"

PRINT USING FMT1\$: SEC, ALT, HDOT, VT, ALF, GAM, PITCH, GREFF, WXDT, WZX, VDOT, WSALERT%

END SUB

SUB RATES STATIC

' SUBROUTINE RATES *

SNGM = SIN(GM): CSGM = COS(GM): SNAL = SIN(ALPHA): CSAL = COS(ALPHA)

VDOT = G * ((THRST * CSAL - DRAG) / WG - SNGM) - WXDT * CSGM - WZDT * SNGM

GDOT = G * ((LIFT + THRST * SNAL) / WG - CSGM) + WXDT * SNGM - WZDT * CSGM

GDOT = GDOT / VT

HDOT = 101.28 * (VT * SNGM + WZ)

XDOT = VT * CSGM + WX

AWX = VDOT + WXDT * CSGM + WZDT * SNGM 'Inertial Acc. along Wind_x axis

AWZ = VT * GDOT - WXDT * SNGM + WZDT * CSGM 'Inertial Acc. along Wind_z axis

AU = (AWX * CSAL + AWZ * SNAL) / G 'LONG. ACCEL. ->=?

AZ = (AWX * SNGM + AWZ * CSGM) / G 'VERT. ACCEL. UP=?

```

VG = XDOT
GRND = (VT * GM + WZ) / (VT + WX) 'Gamma w/r ground
KF1 = 1
GHAT = GMIN * (1 + WX / VT)
IF WZ > -30 AND WZ < -20 THEN KF1 = 1 + .025 * (WZ + 20)
IF WZ <= -30 THEN KF1 = .75
DGAM = 57.3 * (20 * GDOT - (GHAT - GRND + (1 - KF1) * WZ / 152 + 20 * GDOT))
IF DGAM < 0 THEN
KF2 = (2 + .4 * DGAM)
ELSE
KF2 = 2
END IF
IF KF2 < 0 THEN KF2 = 0
KF2 = KF2 / 57.3
END SUB
SUB TAKEOFF STATIC
*****
' SUBROUTINE INITIALIZE TAKEOFF *
*****
IF APPFLG% = 0 THEN
ALPHA = .12
WHILE (LIFT <= WG)
CALL DRAGS
ALPHA = ALPHA + .01
WEND
GM = (THRST - DRAG) / WG 'COMPUTE POTENTIAL GAMMA
ELSE
GM = -3 / 57.3
ALPHA = 2 / 57.3
CALL DRAGS
TFCT = 1
CALL THRUST
T = DRAG - .052 * WG
IF T < 0 THEN T = .2 * THRST
TFCT = T / THRST
THRST = T
END IF
GMO = GM
CALL RATES
END SUB
SUB THRUST STATIC
*****
' SUBROUTINE EPR/THRUST *
*****
' TAKE-OFF THRUST FOR JT8D-17 ENGINES

```

```

VE = 1.668 * VT
R00 = 14688.74: R01 = -.65187546#: R02 = 6.7371E-05
R10 = -13.9295: R11 = .000751143#: R12 = -1.5405E-07
R20 = .014643: R21 = 5.3444E-07: R22 = -4.8907E-10
AA0 = (R02 * ALT + R01) * ALT + R00
AA1 = (R12 * ALT + R11) * ALT + R10
AA2 = (R22 * ALT + R21) * ALT + R20
THRST = 2 * ((AA2 * VT + AA1) * VT + AA0) *Temp. = 100 F
IF APPFLG% = 1 THEN
IF LC% = 1 AND TFCT < 1 THEN
GMO = .136
TSPL = 5.5
'Engine Spool Up Time
TFCT = TFCT + DT / TSPL
END IF
IF TFCT > 1 THEN TFCT = 1
ELSE
TFCT = 1
END IF
THRST = TFCT * THRST
" THRST = 2 * (((2.64159E-05 * VT + 5.110896E-03) * VT - 12.56476) * VT + 15550)
END SUB
SUB VSHAKER STATIC
'----- COMPUTATION OF Vss AND V2-----
V2 = 145
VTO = V2 + 10' SETS INITAL SPEED EQUAL TO V2 + 10
SELECT CASE FLPS%
CASE 10
IF VTO < 150 THEN VTO = 150 ' TAKEOFF
CASE 18
IF VTO < 148 THEN VTO = 148 ' FLAP
CASE 22
IF VTO < 147 THEN VTO = 147 ' SETTINGS
CASE 33
VTO = 63.11225 + .222468 * WG / 1000 ' APPROACH
CASE 42 ' FLAP
VTO = 62.67386 + .21744 * WG / 1000 ' SETTINGS
CASE ELSE
END SELECT
END SUB
SUB WINDS STATIC
*****
' SUBROUTINE WINDS *
*****
'

```

```
IF TDX > 0 THEN
T1 = 4
T2 = TSH
T3 = T1 + T2
T4 = -4
T5 = T3 + TDX
T6 = T5 - T4
B1 = 3 * WXDTO / T1 ^ 2
A1 = -2 * B1 / (3 * T1)
B2 = 3 * WXDTO / T4 ^ 2
A2 = -2 * B2 / (3 * T4)
IF SEC > T2 AND SEC <= T3 THEN
X = SEC - T2
WXDT = (A1 * X + B1) * X * X
END IF
IF SEC > T5 AND SEC <= T6 THEN
X = SEC - T6
WXDT = (A2 * X + B2) * X * X
END IF
IF SEC > T6 THEN WXDT = 0
WX = WX + WXDT * DT
END IF
IF TDZ > 0 THEN
T1 = 4
T2 = TSV
T3 = T1 + T2
T4 = - 4
T5 = T3 + TDZ
T6 = T5 - T4
B1 = 3 * WZO / T1 ^ 2
A1 = -2 * B1 / (3 * T1)
B2 = 3 * WZO / T4 ^ 2
A2 = -2 * B2 / (3 * T4)
IF SEC > T2 AND SEC <= T3 THEN
X = SEC - T2
WZ = (A1 * X + B1) * X * X
WZC = WZ
END IF
IF SEC > T5 AND SEC <= T6 THEN
X = SEC - T6
WZ = (A2 * X + B2) * X * X
WZC = WZ
END IF
KALT = (-.0000011 * ALT + .00212) * ALT - .0251
IF KALT < 0 OR ALT <= 0 THEN KALT = 0
```

```
KALT = 1
WZ = KALT * WZC
IF SEC > T6 THEN WZ = 0
WZDT = (WZ - WZ1) / DT
WZ1 = WZ
END IF
IF DFW = 1 THEN CALL MCRBRST 'DALLAS Model
END SUB
```

[Amdt ETSO/16]

ETSO-C126c

ED Decision 2020/011/R (applicable from 25.7.2020)

LOCATOR TRANSMITTER**1 Applicability**

This ETSO provides the requirements which Emergency Locator Transmitters that are designed and manufactured on or after the applicability date of this ETSO must meet in order to be identified with the applicable ETSO marking.

2 Procedures

2.1 General

The applicable procedures are detailed in CS-ETSO, [Subpart A](#).

2.2 Specific

None.

3 Technical Conditions

3.1 Basic

3.1.1 Minimum Performance Standard

The applicable standards are those provided in EUROCAE ED-62B, MOPS for Aircraft Emergency Locator Transmitters 406 MHz, dated December 2018 as amended by EUROCAE ED-62B Change 1, dated 16 June 2020.

3.1.2 Environmental Standard

Refer to EUROCAE ED-62B as amended by EUROCAE ED-62B Change 1 and, for categories not addressed in EUROCAE ED-62B, see CS-ETSO, [Subpart A](#), paragraph 2.1.

3.1.3 Software

See CS-ETSO, [Subpart A](#), paragraph 2.2.

3.1.4 Airborne Electronic Hardware

See CS-ETSO, [Subpart A](#), paragraph 2.3.

3.2 Specific

None

3.2.1 Failure Condition Classification

See CS-ETSO, [Subpart A](#), paragraph 2.4.

A failure of the function defined in paragraph 3.1 that results in signal outputs that do not meet the requirements of paragraph 3 is a minor failure condition. A loss of the function defined in paragraph 3.1 is a minor failure condition.

A transmission of an erroneous encoded location for an ELT(DT) is a minor failure condition.

An unintended deployment of an ELT(AD) is a major failure condition.

3.2.2 Documentation

The declaration of design and performance (DDP) shall list the type, class,

categories and capabilities of the ELT, as well as the applicable version of the COSPAS-SARSAT beacon standards.

A copy of the COSPAS-SARSAT approval shall be provided to EASA.

4 Marking

4.1 General

See CS-ETSO, [Subpart A](#), paragraph 1.2.

4.2 Specific

As per EUROCAE ED-62B Sections 3.10, 3.3.3, 2.9.3.2 and 3.8.2.

5 Availability of Referenced Documents

See CS-ETSO, [Subpart A](#), paragraph 3.

[Amdt ETSO/11]

[Amdt ETSO/16]

ETSO-C142b

ED Decision 2020/011/R (applicable from 25.7.2020)

NON-RECHARGEABLE LITHIUM CELLS AND BATTERIES**1 Applicability**

This ETSO provides the requirements which non-rechargeable lithium cells and batteries that are intended to provide power for aircraft equipment, including emergency systems, that are designed and manufactured on or after the effective date of this ETSO must meet in order to be identified with the applicable ETSO marking.

This ETSO is not applicable to coin or button cells that contain less than 2 watt-hours (Wh) of capacity, and that are compliant with the requirements of UL 1642 and the UN transport regulations.

2 Procedures

2.1 General

The applicable procedures are detailed in CS-ETSO, [Subpart A](#).

2.2 Specific

None.

3 Technical Conditions

3.1 Basic

3.1.1 Minimum Performance Standard

RTCA document DO-227A 'Minimum Operational Performance Standard (MOPS) for Non Rechargeable Lithium Batteries' from 21 September 2017, as amended by [Appendix 1](#) to this ETSO.

3.1.2 Environmental Standard

Non-rechargeable lithium cells and batteries must be tested according to RTCA document DO-227A Section 2.0 unless otherwise specified by [Appendix 1](#) to this ETSO.

3.1.3 Software

See CS-ETSO, Subpart A, paragraph 2.2.

3.1.4 Airborne Electronic Hardware

See CS-ETSO, Subpart A, paragraph 2.3.

3.2 Specific

3.2.1 Failure Condition Classification

See CS-ETSO, Subpart A, paragraph 2.4.

4 Marking

4.1 General

See CS-ETSO, [Subpart A](#), paragraph 1.2.

4.2 Specific

Each lithium cell or battery must be marked in accordance with RTCA document DO-227A, Section 2.1.10.

In addition, the non-rechargeable lithium cell, battery or end item must be marked as ETSO-C142b-X as described in the following table:

X	Cell, Battery or End Item
– 1	Cell
– 3	Battery
– 5	End Item
– 7	< 5 Wh within End Item Cells and batteries must meet at a minimum UL1642 and UN 38.3 certification. (see Note below)

Note: For ETSO-C142b-7 approvals, the ETSO marking must be on the End Item. The cell or battery within the End Item must be part marked and identified as a component within the End Item. The cell or battery must have a notation in the manufacturer's documentation that the cell or battery is not to be used in another End Item unless it is tested separately in the new End Item. The End Item is required in order to meet the requirement of this ETSO, and the configuration control documentation must state that the cell or battery is approved based solely on the fact that it is tested and validated within the approved End Item. Only cells or batteries that are approved under the ETSO-C142b End Item article may be used. Cells or batteries should only be used if they are approved by the manufacturer of the article. If a different cell or battery is to be used with this End Item, the manufacturer must submit a new ETSO application (for the End Item) to EASA.

5 Availability of Referenced Documents

See CS-ETSO, [Subpart A](#), paragraph 3.

[Amdt ETSO/3]

[Amdt ETSO/16]

Appendix 1 to ETSO-C142b – Minimum Performance Standard for Lithium Batteries

ED Decision 2020/011/R

This Appendix prescribes the MPS for lithium batteries, as modified by this ETSO.

The standard is modified as follows:

Table 1— Text modifications to RTCA document DO-227A

<i>RTCA DO-227A Section and title:</i>	<i>Current wording:</i>	<i>Modified wording:</i>
1.4 Specific Exclusions from this document	c. Cells or batteries containing less than 2 Watt-hours (Wh) of capacity have sufficiently low energy that the possible hazard is considered low and therefore these cells and batteries are assessed as presenting an acceptably low risk for installation as long as they are compliant with the requirements of UL 1642 [Reference 9]. If compliant with UL 1642 and the UN transport regulations [Reference 10], no other requirements from this MOPS will apply to cells or batteries with less than 2 Wh of capacity.	c. Coin or button cells that contain less than 2 watt-hours (Wh) of capacity have sufficiently low energy that the possible hazard is considered to be low, and therefore these cells and batteries are assessed as presenting an acceptably low risk for installation as long as they are compliant with the requirements of UL 1642 [Reference 9]. If they are compliant with UL 1642 and the UN transport regulations [Reference 10], no other requirements from this MOPS will apply to <u>coin or button</u> cells with less than 2 Wh of capacity.
n/a	./.	d. For non-rechargeable cells and/or batteries that contain less than 5 Wh and have not been tested to RTCA document DO-227A, Sections 1.0 and 2.0, the requirement of this ETSO can be met under the ‘End Item testing’ described in DO-227A, Sections 2.2.3 and 2.4.3. Mark the cell or battery per Section 4.2 of this ETSO (ETSO-C142b-7). Note: For ETSO-C142b-7 approvals, the ETSO marking must be on the End Item and the cell or battery as well. The cell or battery must have a notation in the manufacturer’s documentation that the cell or battery is not to be used in another End Item. The End Item is needed in order to meet the requirement of this ETSO,

RTCA DO-227A Section and title:	Current wording:	Modified wording:
		and the configuration control documentation must state that the cell or battery is approved based solely on the fact that it is tested and validated within the approved End Item. Only cells or batteries that are approved under the ETSO-C142b End Item article may be used. Cells or batteries should only be used if they are approved by the manufacturer of the article. If a different cell or battery is to be used with this End Item, a new ETSO application (for the End Item) must be submitted to EASA.
2.4.1.2.1	(...) Test procedure (...) d. immediately start to discharge the sample cells using the DC power supply set at a constant current and with a voltage of limit of 3 volts. (...)	(...) Test procedure (...) d. immediately start to discharge the sample cells using the DC power supply set at a constant current and with a voltage of limit set to the cell nominal voltage. (...)
2.4.3	(...) Testing shall be accomplished in the order indicated in Figure 2-27. (...) End Item safety tests may be conducted using just two End Items by performing the non-destructive thermal management and load profile test first, followed by the thermal runaway containment tests using the same two End Items (with new batteries). All actual batteries used in the End Item safety tests will have previously passed the End Item vibration and shock tests.	(...) Remove 'Testing shall be accomplished in the order indicated in Figure 2-27'. (...) End Item safety tests may be conducted using just two End Items by performing the non-destructive thermal management and load profile test first, followed by the thermal runaway containment tests using the same two End Items (with new batteries). Remove 'All actual batteries used in the End Item safety tests will have previously passed the End Item vibration and shock tests'.

In addition, in Section 2.4.2.1.7, replace Table 2-2 and Figure 2-16 with the following table and figure:

Time (Hours)	Duration (Hours)	Temperature (°C)	% Relative Humidity
0-24	24	23	50
24-26	2	Ramp to 30	Ramp to 95
26-28	2	Soak 30	95
28-30	2	Ramp to 60	95
30-42	12	Soak 60	95
42-44	2	Ramp to 30	95
44-56	12	Soak 30	95
56-58	2	Ramp to 60	95
58-70	12	Soak 60	95
70-72	2	Ramp to 30	95
72-84	12	Soak 30	95
84-86	2	Ramp to 60	95
86-98	12	Soak 60	95
98-100	2	Ramp to 30	95
100-112	12	Soak 30	95
112-114	2	Ramp to 60	95
114-126	12	Soak 60	95
126-128	2	Ramp to 30	95
128-140	12	Soak 30	95
140-141	1	Ramp to 23	95

Table 2-2: Table of relative humidity / temperature test profile values

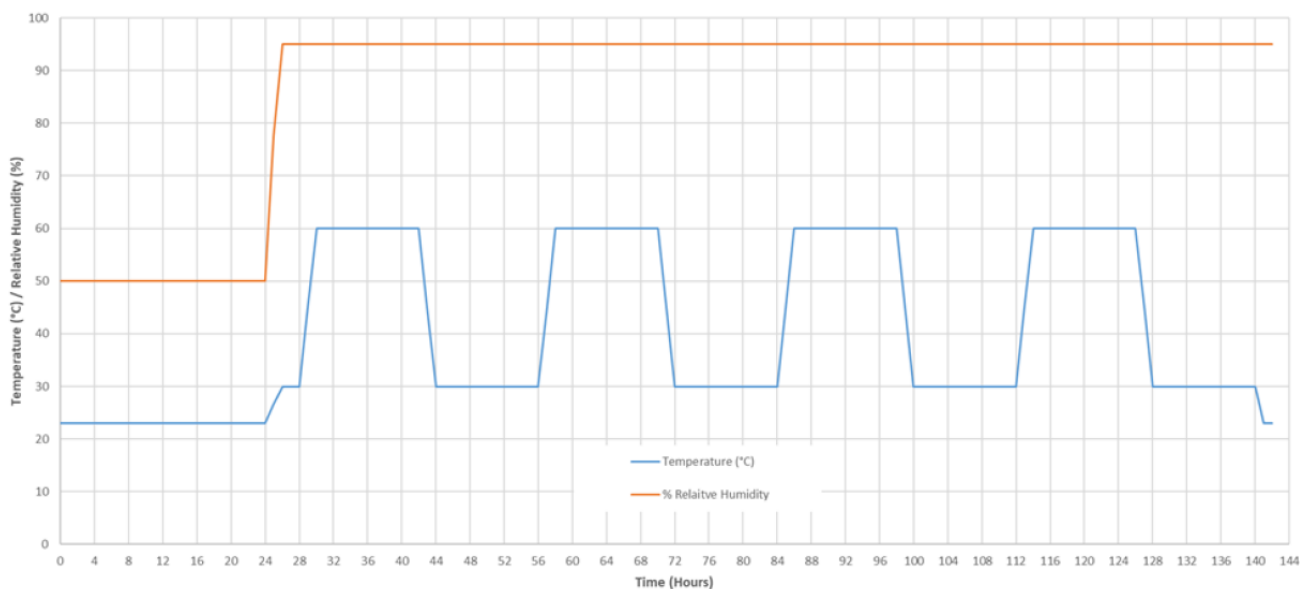

Figure 2-16: Humidity test profile of temperature and humidity versus time

[Amdt ETSO/3]
[Amdt ETSO/16]

ETSO-C145e A1

ED Decision 2020/011/R (applicable from 25.7.2020)

AIRBORNE NAVIGATION SENSORS USING THE GLOBAL POSITIONING SYSTEM AUGMENTED BY THE SATELLITE-BASED AUGMENTATION SYSTEM

1 Applicability

This ETSO provides the requirements which airborne navigation sensors using the Global Positioning System (GPS) augmented by the Satellite Based Augmentation System (SBAS) that are designed and manufactured on or after the date of this ETSO must meet in order to be identified with the applicable ETSO marking.

The standards of this ETSO apply to equipment intended to provide position information to a navigation management unit that outputs deviation commands referenced to a desired flight path, pilots or autopilots will use these deviations to guide the aircraft.

Note: Revision A1 provides applicants with an option to use an ETSO-2C204a SBAS circuit card assembly (CCA) functional sensor as part of their ETSO application. There is no change to the technical MOPS in comparison with ETSO-C145e.

2 Procedures

2.1 General

The applicable procedures are detailed in CS-ETSO, [Subpart A](#).

2.2 Specific

This section applies only for ETSO articles that use an ETSO-2C204a Beta CCA.

Applicants who use an ETSO-2C204a Beta CCA will need to coordinate with their Beta CCA supplier at least for the following aspects:

2.2.1 Access to the Information of the Selected ETSO-2C204a CCA

The applicant is responsible for establishing the necessary communication channels with the ETSO 2C204a holder company. Applicants who use an ETSO-2C204a SBAS CCA will need to coordinate with their SBAS CCA supplier to obtain the documentation that supports ETSO 2C204a.

The applicant's organisation shall establish a means of communication to obtain timely notifications of design changes, open problem reports (at least the ones that impact the usage of the circuit card assembly), occurrence reports and airworthiness directives that affect or are related to the ETSO 2C204a article.

2.2.2 Assessment of Design Changes

The applicant shall perform an impact analysis of the design changes to the ETSO-2C204a article, and shall perform the necessary development life-cycle activities that are impacted by the ETSO 2C204a changes.

Note: When a major change (as assessed per point 21.A.611) is applied to the ETSO 2C204a article, which is installed in the ETSO-C145e article, it is systematically also considered to be a major change for the ETSO-C145e function.

2.2.3 Assessment and Reporting of Open Problem Reports (OPRs)

The applicant shall perform an assessment of the ETSO-2C204a CCA OPRs. The applicant shall report the resulting open problem reports that affect the ETSO-C145e article.

3 Technical Conditions

3.1 Basic

3.1.1 Minimum Performance Standard

The applicable standards are those provided for functional equipment Class Beta in RTCA document DO-229E, Minimum Operational Performance Standards for Global Positioning System/Wide Area Augmentation System Airborne Equipment dated 15 December 2016, Section 2, as amended by [Appendices 2](#) and 4 to this ETSO.

Class Beta equipment is defined in DO-229E, Section 1.4.

The test procedures are defined in DO-229E, Section 2.5.

The standards in this ETSO apply to equipment intended to provide position, velocity, and time information for a navigation management unit application that outputs deviation commands keyed to a desired flight path, or a non-navigation application such as an automatic dependent surveillance — broadcast (ADS-B) or terrain awareness and warning system (TAWS). In navigation applications, pilots or autopilots will use the deviations output by the navigation management unit to guide the aircraft. In non-navigation applications, the position, velocity, and time outputs will provide the necessary inputs for the end-use equipment. These ETSO standards do not address integration issues with other avionics.

Use of an ETSO-2C204a SBAS CCA functional sensor

ETSO-145e applicants have the option to use an ETSO-2C204a SBAS CCA functional sensor. Applicants who choose to use an ETSO-2C204a SBAS CCA functional sensor can take credit for certification compliance by virtue of the ETSO-2C204a ETSOA for:

- meeting the MPS Section 2.1 requirements;
- the development assurance of the hardware/software;
- the classification of the failure conditions; and
- the MPS Section 2.5 performance testing (functional qualification) except those tests that are specified in Appendix 1 to this document;
- the partial environmental testing performed on the ETSO-2C204a CCA.

After the integration of the ETSO-2C204a CCA into the ETSO-145e article, the applicant shall perform the testing described in Appendix 1. The applicant shall also complete the environmental qualification testing. The testing shall include the detailed functional test procedures delivered by the ETSO-2C204a CCA provider. This testing is required to address the paragraphs of this ETSO that are not covered by the points listed above.

Note: The manufacturer of end-use equipment that uses an ETSO-2C204a SBAS CCA functional sensor assumes full responsibility for its design and function under their ETSO-C145e authorisation.

3.1.2 Environmental Standard

See CS-ETSO [Subpart A](#) paragraph 2.1.

The required performance under test conditions is defined in RTCA document DO-229E, Minimum Operational Performance Standards for Global Positioning System/Satellite Based Augmentation System Airborne Equipment, dated 15 December 2016, Section 2.4.

3.1.3 Software

See CS-ETSO, [Subpart A](#), paragraph 2.2.

Applicants who use an ETSO-2C204a SBAS CCA functional sensor may use the ETSO-2C204a authorisation as substantiation for compliance with the software development assurance aspects of the CCA.

3.1.4 Airborne Electronic Hardware

See CS-ETSO, [Subpart A](#), paragraph 2.3.

Applicants who use an ETSO-2C204a SBAS CCA functional sensor may use the ETSO-2C204a authorisation as substantiation for compliance with the hardware development assurance aspects of the CCA.

3.2 Specific

3.2.1 Failure Condition Classification

See CS-ETSO, [Subpart A](#), paragraph 2.4

Failure of the function defined in paragraph 3.1.1 of this ETSO is a:

- *major* failure condition for a loss of function or malfunction of en route, terminal, approach lateral navigation (LNAV), and approach LNAV/vertical navigation (VNAV) position data,
- *major* failure condition a for loss of function of approach localiser performance without vertical guidance (LP), and of approach localiser performance with vertical guidance (LPV) position data, and
- *hazardous* failure condition for a malfunction of approach (LP and LPV) position data that results in misleading information.

Note: These failure condition classifications are considered to be the minimum classifications. Guidance for the installation of navigation systems at the aircraft level (e.g. Certification Specifications and Acceptable Means of Compliance for Airborne Communications, Navigation and Surveillance (CS ACNS)) could require a different failure condition classification.

3.2.2 Additional Specific

If the equipment can satisfy the requirements of RTCA document DO-229E only when used with a particular antenna, the use of that antenna (by part number) shall be a requirement on the installation. This requirement shall be included in the installation manual as a limitation.

The applicant shall have all the data necessary to evaluate the geostationary (GEO) satellite bias as defined in RTCA document DO-229E, Section 2.1.4.1.5, available for review by EASA.

If the equipment uses barometric-aiding to enhance availability of FDE, then the equipment shall meet the requirements in RTCA document DO-229E, Appendix G.

4 Marking

4.1 General

See CS-ETSO, [Subpart A](#), paragraph 1.2.

4.2 Specific

At least one major component must be permanently and legibly marked with the operational equipment class as defined in Section 1.4.2 of RTCA document DO-229E (e.g. Class 2). The functional equipment class defined in Section 1.4.1 of RTCA document DO-229E (e.g. Beta) is not required to be marked.

It is sufficient to declare the proper functional equipment class in the declaration of design and performance (DDP).

5 Availability of Referenced Documents

See CS-ETSO, [Subpart A](#), paragraph 3.

[Amdt ETSO/6]

[Amdt ETSO/13]

[Amdt ETSO/16]

Appendix 1 to ETSO-C145e A1 – End-Use Equipment Manufacturer Tests for SBAS CCA Functional Position, Velocity, Time (PVT) Sensors Used for Navigation and Non-Navigation Applications

ED Decision 2020/011/R

1. SCOPE

This Appendix describes the required supplementary equipment level testing, in addition to the environmental testing of RTCA document DO-229E, Section 2.4, that is required to be conducted by the manufacturer of the end-use equipment to receive an ETSO-C145e Class Beta authorisation when using an ETSO-2C204a SBAS CCA functional sensor.

To perform functional tests and measure the performance in the environment, the applicant will use the detailed functional test procedures delivered with the ETSO-2C204a CCA. These test procedures are intended to streamline and simplify the ETSO-C145e authorisation process for the manufacturer of the end-use equipment by allowing credit for the design and selected testing performed at the SBAS CCA functional sensor level. However, the manufacturer of the end-use equipment remains fully responsible for the design and control of the article per their ETSO-C145e ETSOA.

2. GENERAL PRINCIPLES

- (a) Testing methods for GPS/SBAS equipment have been standardised by RTCA document DO-229E, and serve as the basis for ETSO-C145e. RTCA document DO-229E was written to cover equipment that can be installed on aircraft. Section 2.4 specifically addresses the issues of the environment in which the equipment operates and provides the approved test methods to validate the performance of the equipment in this environment. Section 2.4 represents the RTCA consensus in identifying which RTCA document DO-229E requirements are sensitive to environmental effects. These requirements are listed in the environmental tables referenced in Section 2.4.1.
- (b) The determination that a MOPS requirement is susceptible to the environment does not depend on whether or not the implementation is a CCA installed within an ETSO-C145e article. This is the same concept as an equipment enclosure that is designed to protect against a benign environment compared with one that is designed for a severe environment; the identification of the susceptible requirements is the same.
- (c) Therefore, this Appendix uses the tables of RTCA document DO-229E Section 2.4.1 to identify the MOPS requirements that are susceptible to environmental effects for an SBAS CCA functional sensor in the end-use equipment. The focus is on the change in environment seen by the SBAS CCA functional sensor as a result of its installation in the end-use equipment. For example, other components inside the end-use equipment may radiate RF energy that could interfere with the GPS functions; therefore, the ambient testing performed at the CCA level is not equivalent to tests performed in the end-use equipment. This is the basis for defining the RTCA document DO-229E Section 2.5 performance tests that need to be repeated by the manufacturer of the end-use equipment.
- (d) The Class Beta environmental table referenced in RTCA document DO-229E Section 2.4.1 is the prime source to determine the MOPS performance requirements that are susceptible to environmental conditions. Based on the table, the susceptible requirements can be grouped into two categories: those that are susceptible to most

types of environmental conditions (described in Section 3) and those that are susceptible to only a few (described in Section 4).

Note: The tables for Class Beta-1, -2, and -3 equipment identify similar requirements that are susceptible to the installed environment. The only difference is the applicable MOPS requirements that are consistent with the operational class (i.e. Class -1, -2, or -3).

3. PERFORMANCE REQUIREMENTS THAT ARE SUSCEPTIBLE TO MOST TYPES OF ENVIRONMENTAL CONDITIONS

The RTCA document DO-229E requirements for accuracy (Sections 2.1.3.1, 2.1.4.1, and 2.1.5.1) and sensitivity and dynamic range (Section 2.1.1.10) are sensitive to most types of environmental conditions. However, these requirements are linked to the message loss rate requirement in 2.1.1.3.2. Sections 3.1 and 3.2 below identify the testing that manufacturers of end-use equipment are required to repeat to demonstrate that the SBAS CCA functional sensor continues to meet the accuracy, dynamic range, and message loss rate performance requirements after installation in the end-use equipment. All the tests shall be run under conditions in which the functions of the end-use equipment are fully enabled to create the worst-case environment.

3.1. RTCA document DO-229E — 2.5.8 Accuracy Test

- (a) The accuracy test described in Section 2.5.8 is actually a joint test that covers accuracy, sensitivity and dynamic range. This joint testing also applies under the environment as stated in Section 2.4.1.1.5, with environmental adaptations as described in Section 2.4.1.1.1.
- (b) The demonstration of accuracy is performed in accordance with Section 2.5.8.1 only for the test case with broadband external interference noise. This test must be repeated when the CCA is installed in the end-use equipment, and it is sufficient to perform it using broadband interference.
 - (1) The environmental testing is limited to broadband interference, as it represents the worst-case signal-to-noise condition, which is the most sensitive to environmental effects. This applies equally to the environment for the CCA that is created by the end-use equipment.
 - (2) Section 2.5.8 contains a measurement accuracy test in 2.5.8.1, with the detailed test procedure in Section 2.5.8.2. The Section 2.5.8.1 test must be run under the worst-case environment identified in the 'Additional Considerations for Internal Interference Sources' section below. The measurement accuracy testing can be combined with the message loss rate testing described in Section 2.5.2.1.
 - (3) Section 2.5.8.3 is a 24-hour actual satellite accuracy test. The Section 2.5.8.3 test exposes the equipment to a variety of signal conditions and data-processing conditions over varying satellite geometries that will increase the confidence that no unforeseen interactions between components within the end-use equipment and the SBAS CCA functional sensor will go undetected. The 24-hour testing in Section 2.5.8.3 can be combined with the 24-hour message loss rate testing described in Section 2.5.2.4 (see the section on 'Additional Considerations for Internal Interference Sources').
 - (4) Section 2.5.8.4 (SBAS Tracking Bias) is an analysis of the GPS hardware, and it is therefore not necessary to repeat it at the end-use equipment level provided that no extra RF components that affect the RF filtering response are inserted in the RF

path. Otherwise, the manufacturer of the end-use equipment must also repeat the SBAS Tracking Bias test.

- (c) The test threshold is relaxed from 110 % to 125 % as specified in Table 2-25 of the 2.5.8.2.1 test procedure to shorten the duration of the test. However, the Section 2.5.8 testing (excluding the SBAS Tracking Bias test in Section 2.5.8.4) for the CCA in the end-use equipment shall be under ambient conditions per Section 2.5 with the 110-% test pass threshold for the maximum test sensitivity.
- (d) The Section 2.5.8 testing (excluding the SBAS Tracking Bias test in Section 2.5.8.4) will be repeated against the accuracy requirements that are consistent with the desired operational class (i.e. the Section 2.1.3.1, 2.1.4.1, and 2.1.5.1 accuracy requirements, as appropriate).
- (e) Only the broadband external interference noise test case using minimum satellite power will be executed in most cases, to shorten the duration of the test. The Section 2.5.8.1 testing will be repeated for both the minimum and the maximum satellite power only for the worst-case environment.

3.2. RTCA document DO-229E — 2.5.2 Message Loss Rate Test

- (a) Section 2.5.2 specifies the message loss rate test for the Section 2.1.1.3.2 message loss rate requirement. This test is conducted in conjunction with the Section 2.5.8 accuracy testing. Section 2.5.2.2 defines the test procedure to collect data to verify the SBAS message loss rate in the presence of interference using the test cases in which the SBAS satellite is at minimum power. Section 2.5.2.3 defines the pass-fail criteria.
- (b) The test in Section 2.5.2.2 is performed during the measurement accuracy broadband interference test case described in paragraph 3.1.
- (c) The test procedure in Section 2.5.2.4.1 is run in conjunction with the Section 2.5.8.3 24-hour accuracy test. Section 2.5.2.4.2 defines the pass-fail criteria for the test case described in paragraph 3.1(b)(3).

4. PERFORMANCE REQUIREMENTS THAT ARE PARTIALLY SUSCEPTIBLE TO ENVIRONMENTAL CONDITIONS

- (a) The Class Beta tables (Tables 2-14, 2-16, and 2-18) in Section 2.4.1 of RTCA document DO-229E indicate that the requirements for the initial acquisition time (2.1.1.7) and the satellite reacquisition time (2.1.1.9) are sensitive to four environmental conditions: icing, lightning-induced transient susceptibility, lightning direct effects, and normal/abnormal operating conditions. The requirements for loss of navigation (2.1.1.13.2, 2.1.4.12.2, and 2.1.5.12.2) and loss of integrity (2.1.1.13.1, 2.1.4.12.1, and 2.1.5.12.1) are sensitive to low and high operating temperatures.
- (b) The lightning-induced transient susceptibility, lightning direct effects, or icing environmental conditions are not pertinent to the environment that is created by the end-use equipment relative to the SBAS CCA functional sensor. However, the manufacturer of the end-use equipment remains responsible for meeting the overall environmental qualification requirements at the end-use equipment level.
- (c) The loss of navigation and loss of integrity indications are limited to temperature testing, and the information in RTCA document DO-229E, Sections 2.4.1.1.2 and 2.4.1.1.3, is appropriate. The purpose is to ensure that the interface used to indicate the loss of navigation is functional under the environmental conditions that are present after the SBAS CCA functional sensor is installed in the end-use equipment. Sections 2.4.1.1.2 and 2.4.1.1.3 indicate that any source that generates the indication can be used, since it is the

interface and not the detection mechanism that is verified. The temperature testing performed at the end-use equipment level is the worst-case scenario. It is not necessary to repeat the CCA-level test at room temperature in the end-use equipment, since the environmental qualification adequately addresses the testing for these requirements.

- (d) EUROCAE ED-14 Section 16 relates to aircraft power supplies (refer to ETSO Section 3.1.2 for the environmental qualification requirements). Sections 16.5.1.2 and 16.6.1.2 are for supply voltage modulation (AC)/ripple (DC). Given the potential susceptibility of the SBAS CCA functional sensor to power supply noise, it is prudent to repeat the tests at the end-use equipment level on this basis.
- (e) Sections 4.1 and 4.2 identify the testing that manufacturers of end-use equipment are required to repeat to demonstrate that the SBAS CCA functional sensor continues to meet the acquisition time and reacquisition time performance requirements relative to the normal/abnormal operating conditions after installation in the end-use equipment. All the tests shall be run under conditions in which the functions of the end-use equipment are fully enabled, to create the worst-case environment.

4.1. RTCA document DO-229E — 2.5.4 Initial acquisition test procedures

The information in RTCA document DO-229E, Section 2.4.1.1.4, on the initial acquisition test in Section 2.5.4 applies. The manufacturer of the end-use equipment shall repeat the initial acquisition testing described in RTCA DO-229E, Section 2.5.4.

4.2. RTCA document DO-229E — 2.5.6 Satellite reacquisition time test.

The manufacturer of the end-use equipment is required to repeat the satellite reacquisition time testing in RTCA document DO-229E, Section 2.5.6.

5. ADDITIONAL CONSIDERATIONS FOR INTERNAL INTERFERENCE SOURCES

- (a) Installing an SBAS CCA functional sensor into end-use equipment that also includes other functions requires a careful evaluation of the potential internal radiated and conducted interference. The manufacturer of the end-use equipment must evaluate each operating mode to determine whether the mode changes the environment for the installed SBAS CCA functional sensor. If there is only one environment, or there is clearly one worst-case environment, then the accuracy and message loss rate testing in Section 3 can be run in that operating mode only. For example, if the end-use equipment includes an RF transmitter that radiates at one frequency, one could reasonably argue that setting the transmitter at full power with maximum data throughput would generate a clear worst-case environment in which to run all the testing.
- (b) In the case of multiple environments, the accuracy and message loss rate tests can either be run in each environment, or the methodology in RTCA document DO-229E, Section 2.4.1.2.3, can be used to run an aggregate test with approximately equal time in each mode. The methodology in Section 2.4.1.2.3 must be used to identify the modes with the greatest susceptibility under which the combined accuracy and message loss rate tests are repeated in addition to the aggregate test. For example, the methodology of Section 2.4.1.2.3 is appropriate for end-use equipment that contains a high-power transmitter that operates on a large number of frequencies such that it is impractical to run a test at each frequency. This is analogous to the large number of frequencies that need to be tested during the EUROCAE ED-14 Section 19 testing on induced signal susceptibility and the Section 20 testing on radio frequency susceptibility, and this is the reason why the methodology of Section 2.4.1.2.3 was developed.

- (c) It is sufficient to identify one worst-case environment when performing acquisition and 24-hour accuracy testing.

6. SUMMARY

- (a) The manufacturer of end-use equipment that incorporates an SBAS CCA functional sensor is required to repeat the following RTCA document DO-229E Section 2.5 testing under ambient conditions (see Section 5) after installing the SBAS CCA functional sensor in the end-use equipment:

- The Section 2.5.8 accuracy test (excluding the SBAS Tracking Bias test in 2.5.8.4) adapted per Section 2.4.1.1.1, except that the 110-% test pass threshold is used.

Note: Excluding the SBAS Tracking Bias test is acceptable, provided that the end-use equipment does not insert into the RF signal path any components that affect the filtering response. Otherwise, the manufacturer of the end-use equipment must repeat the SBAS Tracking Bias test as well.

- The Section 2.5.2 message loss rate test.
- The Section 2.5.4 initial acquisition test.
- The Section 2.5.6 satellite reacquisition time test.

- (b) The manufacturer of the end-use equipment remains responsible for completing a full environmental qualification evaluation (ETSO Section 3.1.2) at the end-use equipment level. The manufacturer of end-use equipment that incorporates an SBAS CCA functional sensor is required to repeat the loss of navigation indication and loss of integrity indication tests as part of the environmental qualification according to RTCA document DO-229E Sections 2.4.1.1.2 and 2.4.1.1.3 respectively.

[Amdt ETSO/13]

[Amdt ETSO/16]

Appendix 2 to ETSO-C145e A1 – Addition to RTCA Document DO-229E Section 1

ED Decision 2020/011/R

This Appendix describes the required modifications and additions to RTCA DO-229E for compliance with this ETSO. This Appendix adds a new Section 1.8.3 and corrects a long-standing mistake in the Section 2.4 environmental requirement tables.

The new section provides information for cybersecurity and spoofing mitigation to make RTCA document DO-229E consistent with the new RTCA MOPS template and RTCA document DO-253D, Minimum Operational Performance Standards for GPS Local Area Augmentation System Airborne Equipment.

1.8.3 Cybersecurity and GNSS Spoofing Mitigation

This section contains information to address intentional interference with the GNSS. Spoofing is caused by RF waveforms that mimic true signals in some ways, but deny, degrade, disrupt, or deceive a receiver's operation when they are processed. Spoofing may be unintentional, such as effects from the signals of a GNSS repeater, or may be intentional and even malicious. There are two classes of spoofing:

- Measurement spoofing introduces RF waveforms that cause the target receiver to produce incorrect measurements of time of arrival or frequency of arrival or their rates of change;
- Data spoofing introduces incorrect digital data to the target receiver for its use in processing of signals and the calculation of positioning, navigation and timing (PNT).

Either class of spoofing can cause a range of effects, from incorrect outputs of PNT to receiver malfunction. The onset of effects can be instantaneous or delayed, and the effects can continue even after the spoofing has ended. Improperly used or installed GNSS re-radiators act like spoofers. Re-radiators replay and GNSS emulator devices can present misleading information to GNSS equipment and/or could cause lasting effects.

Equipment manufacturers should implement measures to mitigate processing of erroneous data. Cross-checks of GNSS sensor data against independent position sources and/or other detection monitors using GNSS signal metrics or data checks can be implemented in the antenna, receiver, and/or through integration with other systems at the aircraft level. Data validity checks to recognize and reject measurement and data spoofing should be implemented in the receiver. Additional guidance and best practices related to GNSS equipment can be found in the U.S. Department of Homeland Security document 'Improving the Operation and Development of Global Positioning System (GPS) Equipment Used by Critical Infrastructure'⁴ and GLOBAL POSITIONING SYSTEMS DIRECTORATE SYSTEMS ENGINEERING & INTEGRATION: INTERFACE SPECIFICATION, IS-GPS-200, Navstar GPS Space Segment/Navigation User Interfaces, Revision H, IRN-IS-200H-003, 28 July 2016.

Aircraft equipment information vulnerabilities (such as cybersecurity risks) have been present for digital systems since the development of the personal computer (PC) in the late 1970s and even longer for RF systems, and the advent of internet connectivity has substantially increased those risks. Typically, access to navigation receivers has been controlled such that they are considered to be vulnerable only through RF signals and OEM and/or aircraft operator controlled processes for maintenance and updates. In some cases, aircraft GNSS receivers may be field-loadable by approved personnel, requiring physical access and physical interface to the ground receivers. However, it is

⁴ [https://ics-cert.us-cert.gov/sites/default/files/documents/Improving_the_Operation_and_Development_of_Global_Positioning_System_\(GPS\)_Equipment_Used_by_Critical_Infrastructure_S508C.pdf](https://ics-cert.us-cert.gov/sites/default/files/documents/Improving_the_Operation_and_Development_of_Global_Positioning_System_(GPS)_Equipment_Used_by_Critical_Infrastructure_S508C.pdf).

expected that not all aircraft in the future will rely on such physical isolation for the security of avionics. Internet and Wi-Fi connectivity have become popular as a means for aircraft or equipment manufacturers to update installed avionics software, to update databases, or provide an alternate means of communicating with the flight crew or cabin (e.g., in-flight entertainment, weather, etc.).

In most countries, the State provides oversight of safety-of-flight systems (sometimes referred to as ‘authorised services’) which provide information to aircraft, such as ILS, VOR, GNSS, and DME, to name a few. However, the State typically does not provide oversight on ‘non-trusted’ connectivity such as the internet, Wi-Fi, or manufacturer-supplied equipment interfaces which permit the input of externally supplied data into aircraft systems. A manufacturer may expose aircraft information vulnerabilities through the design of the equipment, or the equipment may become vulnerable as a result of being connected to a common interface. Therefore, it is important for manufacturers to consider aircraft information security risk mitigation strategies in their equipment design, particularly when the equipment is responsible for an interface between the aircraft and aircraft-external systems.

Apart from any specific aircraft-information-security-related performance requirements that are contained in the MOPS, it is recommended that manufacturers consider a layered approach to aircraft information security risk mitigation that includes both technical (e.g. software, signal filtering) and physical strategies. From a technical perspective, for example, this could include signal spoofing detection capabilities or more stringent, multi-factored authentication techniques such as passwords, PINs, and digital certificates. From a physical perspective, a manufacturer could consider connectors that require special tools to remove them to prevent passenger tampering — although navigation avionics are typically located in an avionics bay inaccessible to passengers. And finally, but just as important, manufacturers should consider supply chain risk management; for example, if a manufacturer outsources the development of software code, are the contractor and its staff properly vetted?

Civil aviation authorities (CAAs) have a regulatory interest when an applicant’s design makes use of a non-trusted connection through which the installation can potentially introduce aircraft information security vulnerabilities. This requires the applicant to address not only the information security vulnerabilities and mitigation techniques for the new installation, but to also consider how vulnerability could propagate to existing downstream systems. Therefore, it is recommended that manufacturers reference their equipment aircraft information security review and mitigation strategies in the installation manual of the equipment so that the applicant can consider them in meeting the regulatory requirements of the installation.

Table 2-14 to Table 2-20

The tables incorrectly reference and label EUROCAE ED-14/RTCA document DO-160 Sections 16.5.1.2 and 16.6.1.2 regarding ‘2.1.1.7 Acquisition Time’ and ‘2.1.1.9 Reacquisition Time’. Change the table references as follows:

The MOPS initial acquisition time requirement (2.1.1.7) applies to both AC and DC equipment under abnormal operating conditions (EUROCAE ED-14/RTCA document DO-160 Sections 16.5.2 and 16.6.2) and the satellite reacquisition time requirement (2.1.1.9) applies to both AC and DC equipment under normal operating conditions (EUROCAE ED-14/RTCA document DO 160 Sections 16.5.1 and 16.6.1).

[Amdt ETSO/13]

[Amdt ETSO/16]

Appendix 3 to ETSO-C145e A1

ED Decision 2020/011/R

Reserved.

[Amdt ETSO/13]

[Amdt ETSO/16]

Appendix 4 to ETSO-C145e A1

ED Decision 2020/011/R

This Appendix prescribes the EASA modifications to RTCA document DO-229E, Section 2.

In Section 2.1.1.2, after the first sentence, add the following:

‘The demodulation of data from the GPS signals shall be restricted to the necessary subset of the data defined in Appendix II to IS-GPS-200D, ‘Navstar GPS Space Segment / Navigation User Interfaces’, December 2004, provided on RF link L1. The pseudo-ranging shall be performed on RF link L1 utilising the coarse/acquisition (C/A) code.’

This is to ensure that only the L1 NAV data, for which the SBAS provides corrections and integrity, is used, and that no CNAV data, which is defined in Appendix III to IS-GPS-200D, is used, for which the SBAS does not provide integrity.

[Amdt ETSO/13]

[Amdt ETSO/16]

ETSO-C146e A1

ED Decision 2020/011/R (applicable from 25.7.2020)

STAND-ALONE AIRBORNE NAVIGATION EQUIPMENT USING THE GLOBAL POSITIONING SYSTEM AUGMENTED BY THE SATELLITE-BASED AUGMENTATION SYSTEM

1 Applicability

This ETSO provides the requirements which stand-alone airborne navigation equipment using the Global Positioning System (GPS) augmented by the Satellite-Based Augmentation System (SBAS) that is designed and manufactured on or after the date of this ETSO must meet in order to be identified with the applicable ETSO marking.

Note: Revision A1 provides applicants with an option to use an ETSO-2C205a Class Delta circuit card assembly (CCA) functional sensor as part of their ETSO application. There is no technical MOPS change in comparison with ETSO-C146e.

2 Procedures

2.1 General

The applicable procedures are detailed in CS-ETSO, [Subpart A](#).

2.2 Specific

This section only applies to ETSO articles that use an ETSO-2C205a CCA.

Applicants that use an ETSO-2C205a CCA will need to coordinate with their CCA supplier for at least the following aspects:

2.2.1 Access to the Information on the Selected ETSO-2C205a CCA

The applicant is responsible for establishing the necessary communication channels with the ETSO 2C205a holder company. Applicants who use an ETSO-2C205a SBAS CCA will need to coordinate with their SBAS CCA supplier to obtain the documentation that supports ETSO 2C205a.

The applicant's organisation shall establish a means of communication to obtain timely notifications of design changes, open problem reports (at least the ones that impact the usage of the CCA), occurrence reports and airworthiness directives that affect or relate to the ETSO 2C205a article.

2.2.2 Assessment of Design Changes

The applicant shall perform an impact analysis of the design changes to the ETSO 2C205a article, and shall perform the necessary development life-cycle activities that are impacted by the ETSO-2C205a changes.

Note: When a major change (as assessed per point 21.A.611) is applied to the ETSO 2C205a article, which is installed into the ETSO-C146e article, it is systematically also considered to be a major change for the ETSO-C146e function.

2.2.3 Assessment and Reporting of Open Problem Reports (OPRs)

The applicant shall perform the assessment of the ETSO-2C205a CCA OPRs. The applicant shall report the resulting OPRs that affect the ETSO-C146e article.

3 Technical Conditions

3.1 Basic

3.1.1 Minimum Performance Standard

The applicable standards are those provided for functional equipment Class Gamma or Delta in RTCA document DO-229E, Minimum Operational Performance Standards for Global Positioning System/Satellite-Based Augmentation System Airborne Equipment, dated 15 December 2006, Section 2, as amended by [Appendices 2](#) and [4](#) to this ETSO.

Classes Gamma and Delta of equipment are defined in DO-229E, Section 1.4.

The test procedures are defined in DO-229E, Section 2.5.

The standards in this ETSO apply to equipment intended to accept a desired flight path and provide deviation commands keyed to that path. Pilots and autopilots will use these deviations to guide the aircraft. Except for automatic dependent surveillance with Class Gamma, these ETSO standards do not address integration issues with other avionics.

Use of an ETSO-2C205a Class Delta CCA functional sensor

Applicants for Class Delta-4 ETSO-146e have the option to use an ETSO-2C205a Delta CCA functional sensor. Applicants who choose to use an ETSO-2C205a Delta CCA can take credit for certification compliance by virtue of the ETSO-2C205a ETSOA for:

- meeting the Class Delta-4 MPS requirements in Sections 2.1.1, 2.1.5, and 2.3;
- the development assurance of the hardware/software;
- the classification of failure conditions;
- the MPS Section 2.5 performance testing (functional qualification), except that specified in Appendix 1 to this document; and
- the partial environmental testing performed on the ETSO-2C205a CCA.

After the integration of the ETSO-2C205a CCA into the ETSO-146e article, the applicant shall perform the testing described in Appendix 1. The applicant shall also complete the environmental qualification testing. The testing shall include the detailed functional test procedures delivered by the ETSO-2C205a CCA provider. This testing is required to address the paragraphs of this ETSO that are not covered by the items listed above.

Note: An end-use manufacturer that uses an ETSO-2C205a SBAS CCA functional sensor assumes full responsibility for the design and its function under their ETSO-C146e authorisation.

3.1.2 Environmental Standard

See CS-ETSO, [Subpart A](#), paragraph 2.1. The required performance under test conditions is defined in RTCA document DO-229E, Minimum Operational Performance Standards for Global Positioning System/Satellite-Based Augmentation System Airborne Equipment, dated 15 December 2016, Section 2.4.

3.1.3 Software

See CS-ETSO, [Subpart A](#), paragraph 2.2.

Applicants who use an ETSO-2C205a Class Delta CCA functional sensor may use the ETSO 2C205a authorisation as substantiation for compliance with the software development assurance aspects of the CCA.

3.1.4 Electronic Hardware Qualification.

See CS-ETSO, [Subpart A](#), paragraph 2.3.

Applicants who use an ETSO-2C205a Class Delta CCA functional sensor may use the ETSO 2C205a authorisation as substantiation for compliance with the hardware development assurance aspects of the CCA.

3.2 Specific

3.2.1 Failure Condition Classification

See CS-ETSO, [Subpart A](#), paragraph 2.4.

Failure of the function defined in paragraph 3.1.1 of this ETSO is a:

- major failure condition for a loss of function or malfunction of en route, terminal, approach lateral navigation (LNAV), and approach LNAV/vertical navigation (VNAV) position data,
- major failure condition for a loss of function of approach localiser performance without vertical guidance (LP), and of approach localiser performance with vertical guidance (LPV) position data, and
- Hazardous failure condition for the malfunction of approach (LP and LPV) position data that results in misleading information.

Note: These failure condition classifications are considered to be the minimum classifications. Guidance for the installation of navigation systems at the aircraft level (e.g. Certification Specifications and Acceptable Means of Compliance for Airborne Communications, Navigation and Surveillance (CS-ACNS)) could require different failure condition classifications.

3.2.2 Additional Specific

If the equipment can satisfy the requirements of RTCA/DO-229E only when used with a particular antenna, the use of that antenna (by part number) shall be a requirement on the installation. This requirement shall be included in the installation manual as a limitation.

Applicants shall have all the data necessary to evaluate the geo stationary (GEO) satellite bias as defined in RTCA DO-229E, Section 2.1.4.1.5 available for review by EASA.

If the equipment uses barometric-aiding to enhance the availability of the FDE, then the equipment shall meet the requirements in RTCA DO-229E, Appendix G.

4 Marking

4.1 General

See CS-ETSO, [Subpart A](#), paragraph 1.2.

4.2 Specific

At least one major component shall be permanently and legibly marked with the operational equipment class as defined in Section 1.4.2 of RTCA document DO-229E (e.g. Class 2). A marking of Class 4 indicates compliance with the Delta-4 requirements. The

functional equipment class defined in Section 1.4.1 of RTCA document DO-229E (e.g. Gamma, Delta) is not required to be marked.

It is sufficient to declare the proper functional equipment class in the declaration of design and performance (DDP).

5 Availability of Referenced Documents

See CS-ETSO, [Subpart A](#), paragraph 3.

[Amdt ETSO/6]

[Amdt ETSO/13]

[Amdt ETSO/16]

Appendix 1 to ETSO-C146e A1– End-Use Equipment Manufacturer Tests after Integration of Delta CCA Functional Sensors Used for Navigation Applications

ED Decision 2020/011/R

1. SCOPE

This Appendix describes the required supplementary equipment level testing, in addition to the environmental testing of RTCA document DO-229E, Section 2.4, that the manufacturer of end-use equipment is required to conduct to receive an ETSO-C146e Class Delta-4 authorisation when using an ETSO-2C205a Delta CCA functional sensor.

To perform functional tests and to measure the performance in the environment, the applicant will use the detailed functional test procedures delivered with the ETSO-2C205a CCA. These test procedures are intended to streamline and simplify the ETSO-C146e authorisation process for the manufacturer of the end-use equipment by allowing credit for the design and for selected testing performed at the Delta CCA functional sensor level. However, the manufacturer of the end-use equipment remains fully responsible for the design and control of the article per their ETSO-C146e ETSOA.

2. GENERAL PRINCIPLES

- (a) Testing methods for GPS/SBAS equipment have been standardised by RTCA document DO-229E, and serve as the basis for ETSO-C146e. RTCA document DO-229E was written to cover equipment that can be installed on aircraft. Section 2.4 specifically addresses the issues of the environment in which the equipment operates, and provides the approved test methods to validate its performance in this environment. Section 2.4 represents the RTCA consensus in identifying which RTCA document DO-229E requirements are sensitive to environmental effects. These requirements are listed in the environmental tables referenced in Section 2.4.1.
- (b) The determination that a MOPS requirement is susceptible to the environment does not depend on whether or not the implementation is a CCA installed within ETSO-C146e article. This is the same concept as an equipment enclosure that is designed to protect against a benign environment compared with one designed for a severe environment; the identification of the susceptible requirements is the same.
- (c) Therefore, this Appendix uses the tables of RTCA document DO-229E, Section 2.4.1, to identify the MOPS requirements that are susceptible to environmental conditions for a Delta CCA functional sensor in the end-use equipment. The focus is on the change in environment seen by the Delta CCA functional sensor as a result of its installation in the end-use equipment. For example, other components inside the end-use equipment may radiate RF energy that could interfere with the GPS functions; therefore, the ambient testing performed at the CCA level is not equivalent to tests performed in the end-use equipment. This is the basis for defining the RTCA document DO-229E Section 2.5 performance tests that need to be repeated by the manufacturer of the end-use equipment.
- (d) The Class Delta-4 environmental table referenced in RTCA document DO-229E, Section 2.4.1, is the prime source to determine the MOPS performance requirements that are susceptible to environmental conditions. Based on that table, Class Delta-4 has the same susceptible requirements as Class Beta, but adds two additional requirements for navigation displays and databases that are optional capabilities for Class Delta-4. Those

Delta-4 requirements that are similar to those for Class Beta can be grouped in two categories: those that are susceptible to most types of environmental conditions (described in Section 3) and those that are susceptible to only a few (described in Section 4).

- (e) The options for databases and navigation displays in Delta-4 equipment do not present any repeat MOPS testing requirements for a manufacturer who incorporates an ETSO-2C205a Delta CCA functional sensor in its ETSO-C146e article. The environmental qualification performed by the end-use equipment manufacturer according to ETSO-C146e is sufficient. The rationale is stated below.
 - (1) The database requirement testing in the environment is meant to ensure that the database storage hardware, which may be separate, is fully functional during the environmental testing. As the pass criterion for such testing is that the retrieved data is correct, the test procedures in the environment are as sensitive to hardware issues as any ambient environment test. Therefore, nothing justifies repeating the tests under ambient conditions in the end-use equipment.
 - (2) Manufacturers of end-use equipment that includes a database must perform the environmental qualification specified by ETSO-C146e and MOPS Section 2.4 irrespective of whether the database is hosted in the Delta CCA functional sensor or elsewhere in the equipment.
 - (3) It is impossible for the Delta CCA functional sensor to incorporate a display or to be a display.

3. PERFORMANCE REQUIREMENTS THAT ARE SUSCEPTIBLE TO MOST ENVIRONMENTAL CONDITIONS

The RTCA document DO-229E requirements for accuracy (Section 2.1.5.1), and sensitivity and dynamic range (Section 2.1.1.10) are sensitive to most environmental conditions. However, these requirements are linked to the message loss rate requirement in Section 2.1.1.3.2. Sections 3.1 and 3.2 below identify the testing that manufacturers of end-use equipment are required to repeat to demonstrate that the Delta CCA functional sensor continues to meet the accuracy, dynamic range and message loss rate performance requirements after installation in the end-use equipment. All the tests shall be run under conditions in which the functions of the end-use equipment are fully enabled to create the worst-case environment.

3.1. RTCA document DO-229E — 2.5.8 Accuracy Test

- (a) The accuracy test described in Section 2.5.8 is actually a joint test that covers accuracy, sensitivity and dynamic range. This joint testing also applies in the environment as stated in Section 2.4.1.1.5, with the environmental adaptations as described in Section 2.4.1.1.1.
- (b) The demonstration of accuracy is performed in accordance with Section 2.5.8.1 only for the test case with broadband external interference noise. This test must be repeated when the CCA is installed in the end-use equipment, and it is sufficient to perform it using broadband interference.
 - (1) The environmental testing is limited to broadband interference, as it represents the worst-case signal-to-noise condition, which is the most sensitive to environmental effects. This applies equally to the environment for the CCA that is created by the end-use equipment.
 - (2) Section 2.5.8 contains a measurement accuracy test in Section 2.5.8.1, with the detailed test procedure in Section 2.5.8.2. The Section 2.5.8.1 test must be run under the worst-case environment identified in the section on 'Additional

considerations for internal interference sources' below. The measurement accuracy testing can be combined with the message loss rate testing in Section 2.5.2.1.

- (3) Section 2.5.8.3 is a 24-hour actual satellite accuracy test. The Section 2.5.8.3 test exposes the equipment to a variety of signal conditions and data-processing conditions over varying satellite geometries that will increase the confidence that no unforeseen interactions between the components within the end-use equipment and the Delta CCA functional sensor will go undetected. The 24-hour testing in Section 2.5.8.3 can be combined with the 24-hour message loss rate testing in Section 2.5.2.4 (see the section on 'Additional considerations for internal interference sources').
 - (4) Section 2.5.8.4 (SBAS Tracking Bias) is an analysis of the GPS hardware, and it is therefore not necessary to repeat it at the end-use equipment level provided that no extra RF components that affect the RF filtering response are inserted into the RF path. Otherwise, the manufacturer of the end-use equipment must also repeat the SBAS Tracking Bias test.
- (c) The test threshold is relaxed from 110 % to 125 % as specified in Table 2-25 of the Section 2.5.8.2.1 test procedure to shorten the duration of the test. However, the Section 2.5.8 testing (excluding the SBAS Tracking Bias test in 2.5.8.4) for the CCA in the end-use equipment shall be under ambient conditions per Section 2.5, with the 110-% test pass threshold for maximum test sensitivity.
 - (d) The Section 2.5.8 testing (excluding the SBAS Tracking Bias test in Section 2.5.8.4) should be repeated against the accuracy requirement in Section 2.1.5.1.
 - (e) Only the test case for broadband external interference noise using minimum satellite power will be executed in most cases to shorten the duration of the test. The Section 2.5.8.1 testing will be repeated for both the minimum and the maximum satellite power only for the worst-case environment.
- 3.2. RTCA document DO-229E — 2.5.2 Message Loss Rate Test
- (a) Section 2.5.2 specifies the message loss rate test for the 2.1.1.3.2 message loss rate requirement. This test is conducted in conjunction with the Section 2.5.8 accuracy testing. Section 2.5.2.2 defines the test procedure to collect data that verifies the SBAS message loss rate in the presence of interference using the test cases in which the SBAS satellite is at minimum power. Section 2.5.2.3 defines the pass-fail criteria.
 - (b) The test in Section 2.5.2.2 will be performed during the measurement accuracy broadband interference test case described in paragraph 3.1.
 - (c) The test procedure in Section 2.5.2.4.1 is run in conjunction with the 2.5.8.3 24-hour accuracy test. Section 2.5.2.4.2 defines the pass-fail criteria for the test case described in paragraph 3.1(b)(3).
4. PERFORMANCE REQUIREMENTS PARTIALLY SUSCEPTIBLE TO ENVIRONMENTAL CONDITIONS
- (a) The Class Delta-4 Table 2-20 in Section 2.4.1 of RTCA document DO-229E indicates that the requirements for initial acquisition time (2.1.1.7) and satellite reacquisition time (2.1.1.9) are sensitive to four environmental conditions: icing, lightning-induced transient susceptibility, lightning direct effects, and normal/abnormal operating conditions. The requirements for loss of navigation (Sections 2.1.1.13.2, 2.1.5.12.2, and 2.3.6.2) are sensitive to low and high operating temperatures.

Note: Class Delta-4 provides deviation guidance only during the final approach segment of an LP/LPV approach, in which a loss of integrity is treated as a loss of navigation capability.

- (b) The lightning-induced transient susceptibility, lightning direct effects or icing environmental conditions are not pertinent to the environment created by the end-use equipment relative to the Delta CCA functional sensor. However, the manufacturer of the end-use equipment remains responsible for meeting the overall environmental qualification at the end-use equipment level.
- (c) Loss of navigation indications are limited to temperature testing, and the information in RTCA DO-229E, Sections 2.4.1.1.2 and 2.4.1.1.3, is appropriate. The purpose is to ensure that the interface that is used to indicate the loss of navigation is functional under the environmental conditions that are present after the Delta CCA functional sensor is installed in the end-use equipment. Sections 2.4.1.1.2 and 2.4.1.1.3 indicate that any source that generates the indication can be used, since it is the interface, and not the detection mechanism, that is verified. The temperature testing performed at the end-use equipment level is the worst-case scenario. It is not necessary to repeat the CCA level test at room temperature in the end-use equipment since the environmental qualification adequately addresses testing for these requirements.

Note: The Class Delta table requires more than just temperature testing under environment to support the optional display component of Class Delta. Since a CCA cannot be a display or incorporate a display, the additional testing in the environment does not apply.

- (d) EUROCAE ED-14 Section 16 relates to aircraft power supplies (refer to ETSO paragraph 3.1.2 for the environmental qualification requirements). Sections 16.5.1.2 and 16.6.1.2 are for supply voltage modulation (AC)/ripple (DC). Given the potential susceptibility of the Delta CCA functional sensor to power supply noise, it is prudent to repeat the tests at the end-use equipment level on this basis.
- (e) Sections 4.1 and 4.2 identify the testing that manufacturers of end-use equipment are required to repeat to demonstrate that the Delta CCA functional sensor continues to meet the acquisition time and reacquisition time performance requirements relative to the normal/abnormal operating conditions after installation in the end-use equipment.

All tests shall be run under conditions where the functions of the end-use equipment are fully enabled to create the worst-case environment.

4.1. RTCA DO-229E — 2.5.4 Initial acquisition test procedures

The information in RTCA document DO-229E, Section 2.4.1.1.4, on the initial acquisition test in Section 2.5.4 applies. The manufacturer of the end-use equipment shall repeat the initial acquisition testing described in RTCA document DO-229E, Section 2.5.4.

4.2. RTCA DO-229E — 2.5.6 Satellite reacquisition time test

The manufacturer of the end-use equipment is required to repeat the satellite reacquisition time testing in RTCA document DO-229E, Section 2.5.6.

5. ADDITIONAL CONSIDERATIONS FOR INTERNAL INTERFERENCE SOURCES

- (a) Installing a Delta CCA functional sensor into end-use equipment that also includes other functions requires a careful evaluation of the potential internally radiated and conducted interference. The manufacturer of the end-use equipment must evaluate each operating mode to determine whether the mode changes the environment for the installed Delta

CCA functional sensor. If there is only one environment or there is clearly one worst-case environment, then the accuracy and message loss rate testing in Section 3 can be run in that operating mode only. For example, if the end-use equipment includes an RF transmitter that radiates at one frequency, one could reasonably argue that setting the transmitter at full power with maximum data throughput would generate a clear worst-case environment in which to run all the testing.

- (b) In the case of multiple environments, the accuracy and message loss rate tests can either be run under each environment or the methodology in RTCA document DO-229E, Section 2.4.1.2.3, can be used to run an aggregate test with approximately equal time in each mode. The methodology in Section 2.4.1.2.3 must be used to identify the modes with the greatest susceptibility under which the combined accuracy and message loss rate tests are repeated in addition to the aggregate test. For example, the methodology of Section 2.4.1.2.3 is appropriate for end-use equipment that contains a high-power transmitter that operates on a large number of frequencies such that it is impractical to run a test at each frequency. This is analogous to the large number of frequencies that need to be tested during the EUROCAE ED-14 Section 19 testing on induced signal susceptibility and the Section 20 testing on radio frequency susceptibility, and this is the reason why the methodology of Section 2.4.1.2.3 was developed.
- (c) It is sufficient to identify one worst-case environment when performing the acquisition and 24-hour accuracy testing.

6. SUMMARY

- (a) The manufacturer of the end-use equipment that incorporates a Delta CCA functional sensor is required to repeat the following RTCA document DO-229E Section 2.5 testing under ambient conditions (see Section 5) after installing the Delta CCA functional sensor in the end-use equipment:
 - The Section 2.5.8 Accuracy testing (excluding the SBAS Tracking Bias test in 2.5.8.4) adapted per Section 2.4.1.1.1, except that the 110-% test pass threshold is used.
 - Note: Excluding the SBAS Tracking Bias test is acceptable, provided that the end-use equipment does not insert into the RF signal path any components that affect the filtering response. Otherwise, the manufacturer of the end-use equipment must also repeat the SBAS Tracking Bias test.
 - The Section 2.5.2 message loss rate test.
 - The Section 2.5.4 initial acquisition test.
 - The Section 2.5.6 satellite reacquisition time test.
- (b) The manufacturer of the end-use equipment remains responsible for completing a full environmental qualification evaluation (see ETSO Section 3.1.2) at the end-use equipment level. The manufacturer of end-use equipment that incorporates a Delta CCA functional sensor is required to repeat the loss of navigation indication and loss of integrity indication testing as part of the environmental qualification according to RTCA document DO-229E, Sections 2.4.1.1.2 and 2.4.1.1.3.

[Amdt ETSO/13]

[Amdt ETSO/16]

Appendix 2 to ETSO-C146e A1 – Addition to RTCA Document DO-229E, Section 1

ED Decision 2020/011/R

This Appendix describes the required modifications and additions to RTCA document DO-229E for compliance with this ETSO. This Appendix adds a new Section 1.8.3 on cybersecurity and GNSS spoofing mitigation and additional required leg types in Section 2.2.1.3 of RTCA document DO-229E.

The new Section, 1.8.3, contains no new requirements but provides information for cybersecurity and spoofing mitigation to make RTCA document DO-229E consistent with the new RTCA MOPS template and RTCA document DO-253D, Minimum Operational Performance Standards for GPS Local Area Augmentation System Airborne Equipment.

The new 2.2.1.3 leg type requirements are applicable to Class Gamma equipment only and are necessary to properly execute published instrument procedures designed to provide maximum efficiency, flexibility, and aircraft eligibility. These instrument procedure designs may include RNAV components and/or leg types associated with conventional procedures. The modifications and additions to Section 2.2.1.3 are necessary to ensure Class Gamma equipment can properly execute current and future instrument procedure designs.

1.8.3 Cybersecurity and GNSS Spoofing Mitigation

This section contains information to address intentional interference with the GNSS. Spoofing is caused by RF waveforms that mimic true signals in some ways, but deny, degrade, disrupt, or deceive a receiver's operation when they are processed. Spoofing may be unintentional, such as effects from the signals of a GNSS repeater, or may be intentional and even malicious. There are two classes of spoofing. Measurement spoofing introduces RF waveforms that cause the target receiver to produce incorrect measurements of time of arrival or frequency of arrival or their rates of change. Data spoofing introduces incorrect digital data to the target receiver for its use in processing of signals and the calculation of PNT. Either class of spoofing can cause a range of effects, from incorrect outputs of PNT to receiver malfunction. The onset of effects can be instantaneous or delayed, and the effects can continue even after the spoofing has ended. Improperly used or installed GNSS re-radiators act like spoofers. Re-radiators, replay and GNSS emulator devices can present misleading information to GNSS equipment and/or could cause lasting effects.

Equipment manufacturers should implement measures to mitigate processing of erroneous data. Cross-checks of GNSS sensor data against independent position sources and/or other detection monitors using GNSS signal metrics or data checks can be implemented in the antenna, receiver, and/or through integration with other systems at the aircraft level. Data validity checks to recognize and reject measurement and data spoofing should be implemented in the receiver. Additional guidance and best practices related to GNSS equipment can be found in the U.S. Department of Homeland Security document 'Improving the Operation and Development of Global Positioning System (GPS) Equipment Used by Critical Infrastructure'⁵ and GLOBAL POSITIONING SYSTEMS DIRECTORATE SYSTEMS ENGINEERING & INTEGRATION: INTERFACE SPECIFICATION, IS-GPS-200, Navstar GPS Space Segment/Navigation User Interfaces, Revision H, IRN-IS-200H-003 28 July 2016.

Aircraft equipment information vulnerabilities (such as cybersecurity risks) have been present for digital systems since the development of the personal computer (PC) in the late 1970s and even longer for RF systems, and the advent of internet connectivity has substantially increased those risks. Typically, access to navigation receivers has been controlled such that they are considered to be

⁵ [https://ics-cert.us-cert.gov/sites/default/files/documents/Improving the Operation and Development of Global Positioning System \(GPS\) Equipment Used by Critical Infrastructure S508C.pdf](https://ics-cert.us-cert.gov/sites/default/files/documents/Improving%20the%20Operation%20and%20Development%20of%20Global%20Positioning%20System%20(GPS)%20Equipment%20Used%20by%20Critical%20Infrastructure%20S508C.pdf)

vulnerable only through RF signals and OEM and/or aircraft operator controlled processes for maintenance and updates. In some cases, aircraft GNSS receivers may be field loadable by approved personnel, requiring physical access and physical interface to the ground receivers. However, it is expected that not all aircraft in the future will rely on such physical isolation for the security of avionics. Internet and Wi-Fi connectivity have become popular as a means for aircraft or equipment manufacturers to update installed avionics software, to update databases, or provide an alternate means of communicating with the flight crew or cabin (e.g. in-flight entertainment, weather, etc.).

In most countries, the State provides oversight of safety-of-flight systems (sometimes referred to as ‘authorised services’) which provide information to aircraft, such as ILS, VOR, GNSS, and DME, to name a few. However, the State typically does not provide oversight on ‘non-trusted’ connectivity such as the internet, Wi-Fi, or manufacturer-supplied equipment interfaces which permit the input of externally supplied data into aircraft systems. A manufacturer may expose aircraft information vulnerabilities through the design of the equipment, or the equipment may become vulnerable as a result of being connected to a common interface. Therefore, it is important for manufacturers to consider aircraft information security risk mitigation strategies in their equipment design, particularly when the equipment is responsible for an interface between the aircraft and aircraft-external systems.

Apart from any specific aircraft-information-security-related performance requirements that are contained in the MOPS, it is recommended that manufacturers consider a layered approach to aircraft information security risk mitigation that includes both technical (e.g., software, signal filtering) and physical strategies. From a technical perspective, for example, this could include signal spoofing detection capabilities or more stringent, multi-factored authentication techniques such as passwords, PINs, and digital certificates. From a physical perspective, a manufacturer could consider connectors that require special tools to remove them to prevent passenger tampering — although navigation avionics are typically located in an avionics bay inaccessible to passengers. And finally, but just as important, manufacturers should consider supply chain risk management; for example, if a manufacturer outsources the development of software code, is the contractor and its staff properly vetted?

Civil aviation authorities (CAAs) have a regulatory interest when an applicant’s design makes use of a non-trusted connection through which the installation can potentially introduce aircraft information security vulnerability. This requires the applicant to address not only the information security vulnerabilities and mitigation techniques for the new installation, but to also consider how vulnerabilities could propagate to existing downstream systems. Therefore, it is recommended that manufacturers reference their equipment aircraft information security review and mitigation strategies in the installation manual of the equipment so that the applicant can consider them in meeting the regulatory requirements of the installation.

2.2.1.3 Path Definition

Replace the list of required leg types in the first paragraph after the last sentence as shown:

The desired path shall be defined according to the following leg types:

Leg Type	Description
IF	Initial Fix
CF	Course to Fix leg
DF	Direct to Fix leg
TF	Track to Fix leg
FA	Fix to Altitude leg
FM	Fix to Manual Termination
VA	Heading to Altitude leg
VI	Heading to Intercept

Leg Type	Description
VM	Heading to Manual Termination
CA	Course to Altitude Leg

Holding legs

Leg Type	Description
HA	Terminates at an altitude
HF	Terminates at a fix after one orbit
HM	Manual termination

Note 1: There is no intent to require a heading or altitude source connected to the equipment to automatically execute leg types with heading or altitude components. Manual equipment inputs for heading/altitude with manual aircraft control methods are acceptable for these leg types.

Note 2: Cross-track deviation requirements are not applicable for VA, VI, and VM heading leg types.

Replace Section 2.2.1.3.6 as shown and add the following leg type descriptions. Renumber existing paragraphs (starting with 2.2.1.3.7) to account for the newly added sections:

2.2.1.3.6 Fix to Altitude (FA)

An FA leg shall be defined as a specified track over the ground from a database waypoint to a specified altitude at an unspecified position.



2.2.1.3.7 Fix to Manual Termination (FM)

An FM leg shall be defined as a specified track over the ground from a database fix until a manual termination of the leg.

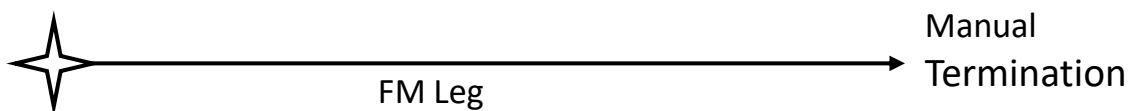

2.2.1.3.8 Heading to Altitude (VA)

A VA leg shall be defined as a specified heading to a specific altitude termination at an unspecified position. No correction is made for wind.

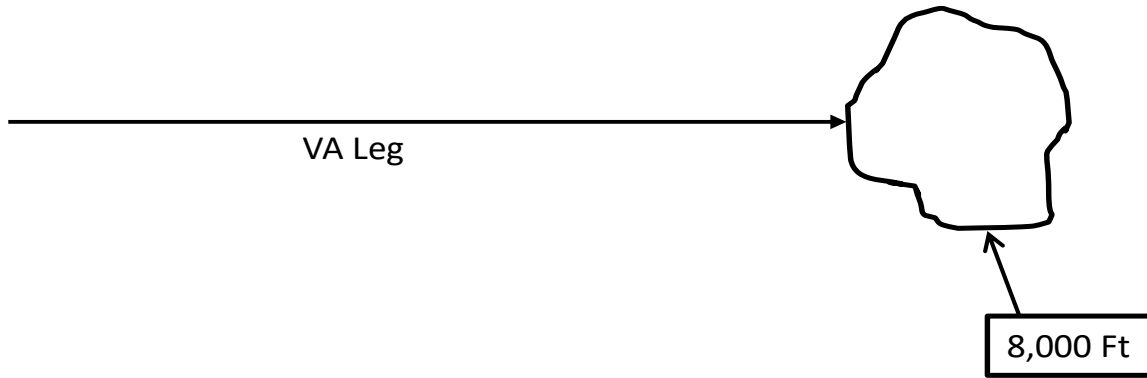

2.2.1.3.9 Heading to Intercept (VI)

A VI leg shall be defined as a specified heading to intercept a subsequent leg at an unspecified position. No correction is made for wind.

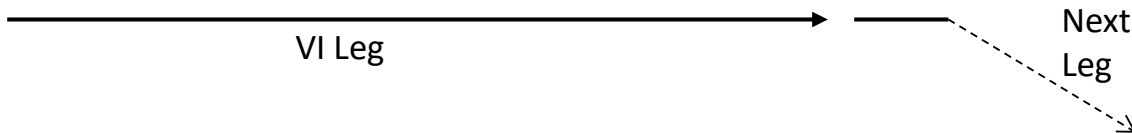

2.2.1.3.10 Heading to Manual Termination (VM)

A VM leg shall be defined as a specified heading until a manual termination of the leg. No correction is made for wind.

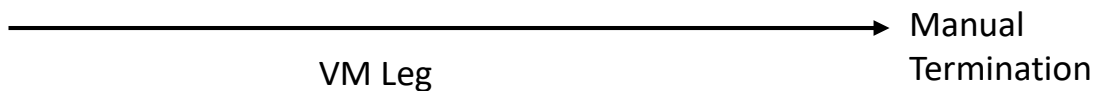

[...]

2.2.1.3.12 Course to Altitude (CA)

A CA leg shall be defined as a specified course to a specific altitude at an unspecified position. The course is flown making adjustment for wind.

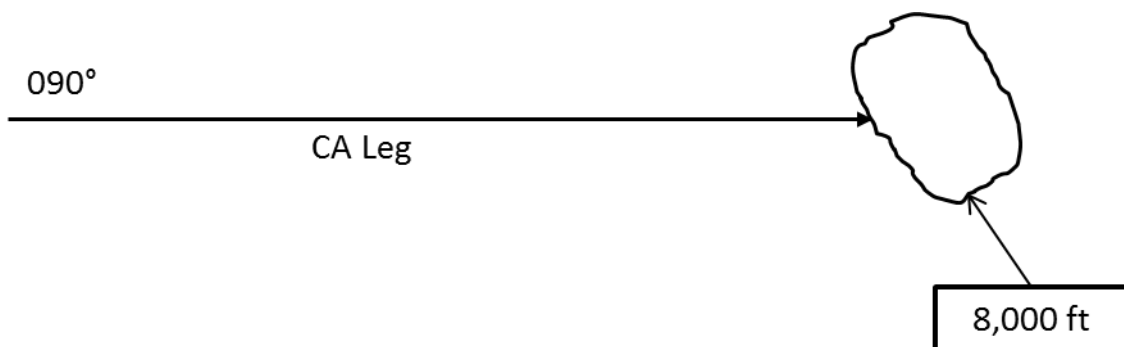

2.2.1.3.13 Hold to Altitude (HA)

An HA leg is a holding pattern which terminates at the next crossing of the hold fix when the aircraft altitude is at or above the specified altitude. The altitude is provided by the navigation database. The source of the magnetic variation needed to convert magnetic courses to true courses is detailed in Section 2.2.1.3.12.

2.2.1.3.14 Hold to Fix (HF)

An HF leg is a holding pattern which terminates at the first crossing of the hold fix after becoming established on the inbound course. This is typically after the entry procedure is performed. The source of the magnetic variation needed to convert magnetic courses to true courses is detailed in Section 2.2.1.3.12.

2.2.1.3.14 Hold for Clearance (manual termination) (HM)

An HM leg is a holding pattern which terminates only after flight crew action. The source of the magnetic variation needed to convert magnetic courses to true courses is detailed in Section 2.2.1.3.12.

Table 2-14 to Table 2-20

The tables incorrectly reference and label EUROCAE ED-14/RTCA document DO-160 Sections 16.5.1.2 and 16.6.1.2 regarding '2.1.1.7 Acquisition Time' and '2.1.1.9 Reacquisition Time'. Change the table references as follows:

The MOPS Initial Acquisition Time requirement (2.1.1.7) applies to both AC and DC equipment under abnormal operating conditions (EUROCAE ED-14/RTCA document DO-160 Sections 16.5.2 and 16.6.2) and the satellite reacquisition time requirement (2.1.1.9) applies to both AC and DC equipment under normal operating conditions (EUROCAE ED-14/RTCA document DO-160 Sections 16.5.1 and 16.6.1).

[Amdt ETSO/13]

[Amdt ETSO/16]

Appendix 3 to ETSO-C146e A1

ED Decision 2020/011/R

Reserved.

[Amdt ETSO/13]

[Amdt ETSO/16]

Appendix 4 to ETSO-C146e A1

ED Decision 2020/011/R

This Appendix prescribes the EASA modifications to RTCA document DO-229E, Section 2.

At Section 2.1.1.2, after the first sentence, add the following:

‘The demodulation of data from the GPS signals shall be restricted to the necessary subset of the data defined in Appendix II to IS-GPS-200D, “Navstar GPS Space Segment/Navigation User Interfaces”, December 2004, provided on RF link L1. The pseudo-ranging shall be performed on RF link L1 utilising the coarse/acquisition (C/A) code.’

This is to ensure that only the L1 NAV data, for which the SBAS provides corrections and integrity, is used, and no CNAV data, which is defined in Appendix III to IS-GPS-200D, is used, for which the SBAS does not provide integrity.

[Amdt ETSO/13]

[Amdt ETSO/16]

ETSO-C151d

ED Decision 2020/011/R (applicable from 25.7.2020)

TERRAIN AWARENESS AND WARNING SYSTEM (TAWS)**1 Applicability**

This ETSO provides the requirements which Terrain Awareness and Warning Systems (TAWS) intended for installation in fixed-wing aircraft that are designed and manufactured on or after the date of this ETSO must meet in order to be identified with the applicable ETSO marking.

2 Procedures

2.1 General

The applicable procedures are detailed in CS-ETSO, [Subpart A](#).

2.2 Specific

None.

3 Technical Conditions

3.1 Basic

3.1.1 Minimum Performance Standard

The applicable standards are those provided in RTCA document DO-367, Minimum Operational Performance Standard (MOPS) for Terrain Awareness and Warning Systems (TAWS) Airborne Equipment, Section 2, dated 31 May 2017. Requirements for Class A, Class B and Class C equipment are provided in RTCA document DO-367 Sections 2.2.1, 2.2.2 and 2.2.3 respectively and amended as follows:

In Section 2.2.1.1.6.3.1 Aural Alert — Caution

The sentences

‘For a caution level FLTA alert due to a predicted terrain conflict, Class A Equipment shall (TAWS_MOPS_051) be capable of generating or triggering an aural message of at least one of “Terrain Ahead” and “Caution Terrain”. The requirement does not imply that Class A Equipment must be able to support both aural messages, although it is permissible for Class A Equipment to support both messages.’

should be replaced by

‘For a caution level FLTA alert due to a predicted terrain conflict, Class A Equipment shall (TAWS_MOPS_051) be capable of generating or triggering both types of aural messages: ~~at least one of~~ “Terrain Ahead” and “Caution Terrain”.

~~The requirement does not imply that Class A Equipment must be able to support both these aural messages, although it is permissible for Class A Equipment to support both messages.’~~

In Section 2.2.1.1.6.3.2 Aural Alert — Warning

The sentences

‘For a warning level FLTA alert due to a predicted terrain conflict, Class A Equipment shall (TAWS_MOPS_053) be capable of generating or

triggering an aural message of at least one of “Terrain Ahead. Pull up” and “Terrain. Terrain, Pull up”.

The requirement does not imply that Class A Equipment must be able to support both aural messages. although it is permissible for Class A Equipment to support both messages.’

should be replaced by

‘For a warning level FLTA alert due to a predicted terrain conflict, Class A Equipment shall (TAWS_MOPS_053) be capable of generating or triggering both types of aural messages: ~~of at least one of~~ “Terrain Ahead. Pull up” and “Terrain. Terrain, Pull up”.

~~The requirement does not imply that Class A Equipment must be able to support both these aural messages. although it is permissible for Class A Equipment to support both messages.’.~~

3.1.2 Environmental Standard

See CS-ETSO, [Subpart A](#), paragraph 2.1.

3.1.3 Computer Software

See CS-ETSO, [Subpart A](#), paragraph 2.2.

3.1.4 Airborne Electronic Hardware

See CS-ETSO, [Subpart A](#), paragraph 2.3.

3.2 Specific

3.2.1 Failure Condition Classification

See CS-ETSO, [Subpart A](#), paragraph 2.4.

For Class A and B ETSO articles, a failure of the function defined in paragraph 3.1.1 due to a TAWS computer malfunction resulting in false terrain warnings, an unannounced loss of function, or the presentation of hazardously misleading information is a major failure condition.

For Class C ETSO articles, a failure of the function defined in paragraph 3.1.1 due to a TAWS computer malfunction resulting in false terrain warnings, an unannounced loss of function, or the presentation of hazardously misleading information is a minor failure condition.

A loss of the function defined in paragraph 3.1.1 is a minor failure condition.

Note: Hazardously misleading information is defined as an incorrect depiction of the terrain threat relative to the aeroplane during an alert condition.

3.2.2 Operating Instructions

Operating instructions and article limitations that are sufficient to describe the operational capability of the equipment, including the coverage of the database (geographical areas and airport characteristics), should be documented and made available to the user. The operating instructions must include information on the effects of a loss of GNSS on the TAWS function if the TAWS relies on the GPS. Additionally, the instructions must contain processes for updating the terrain database.

4 Marking

4.1 General

See CS-ETSO, [Subpart A](#), paragraph 1.2.

4.2 Specific

None.

5 Availability of Referenced Documents

See CS-ETSO, [Subpart A](#), paragraph 3.

[Amdt ETSO/11]

[Amdt ETSO/16]

ETSO-C153a*ED Decision 2020/011/R (applicable from 25.7.2020)***INTEGRATED MODULAR AVIONICS (IMA) PLATFORM AND MODULES**

Note: This ETSO standard is identical to the ETSO-2C153 standard. This new revision has the purpose of aligning the ETSO Index with the published FAA TSO-C153a to reflect harmonisation. As a consequence, this standard is moved from Index 2 to Index 1 of CS-ETSO Subpart B.

1 Applicability

This ETSO provides the requirements that IMA modules, designed to be parts of an Integrated Modular Avionics (IMA) platform and manufactured on or after the date of entry into force of this ETSO, must meet in order to be identified with the applicable ETSO marking.

See Appendix 1 for an introduction to IMA and the applicable definitions.

EUROCAE ED-124 and RTCA DO-297 recognise an incremental IMA system approval by introducing intermediate acceptance steps. ETSO-C153a authorisation is an optional intermediate step to authorise an IMA platform or IMA modules (independently of the aircraft type approval). It encompasses environmental qualification, hardware development assurance, software development assurance and design approval of the intended function of resource sharing.

This ETSO refers to IMA platforms and modules which are appliances composed of hardware, core software or any embedded software module contributing to the intended function of resources sharing.

Nevertheless, if the intended function of resource sharing is implemented:

- the ‘hardware only’ module is acceptable if no further software module is needed to perform resources sharing;
- a single Line Replaceable Unit (LRU) platform (as per EUROCAE ED-124/RTCA DO-297), where the platform is limited to one LRU, is acceptable.

Hereinafter, only the term ‘IMA module’ will be used.

The following are out of the scope of this ETSO-C153a:

- IMA platforms consisting of multiple LRUs or Line Replaceable Modules (LRMs) distributed inside the aircraft that have to be addressed at installation level;
- stand-alone core software;
- configuration data which are part of the IMA system integration and installation;
- hosted applications; and
- equipment used to generate radio frequency signals for intentional transmitters.

To be eligible for an ETSO-C153a authorisation, an IMA module shall comply with common applicable requirements and shall implement at least one of the function classes below:

- CLASS RH: Rack Housing
- CLASS PR: Processing
- CLASS GP: Graphical Processing
- CLASS DS: Data Storage
- CLASS IF: Interface

- CLASS PS: Power Supply
- CLASS DH: Display Head

See [Appendix 2](#) for the common requirements and definitions of function classes.

An IMA module can also be compliant with a combination of MPS classes. In this case, the IMA module will be marked with all the classes it covers. However, if a manufacturer voluntarily applies for an ETSO-C153a authorisation, all the classes for which the intended function is implemented shall be compliant.

Example: A single LRU platform will be authorised as an 'ETSO-C153a CLASS PR + DS + IF' if the intended function of resource sharing is implemented in processing, data storage and the interfaces.

For an ETSO-C153a CLASS DH authorisation, the IMA module shall be compliant with the requirements of ETSO-C113(*) 'Airborne Multipurpose Electronic Displays'. The IMA module shall be marked with both ETSO-C153a CLASS DH and ETSO-C113.

(*) Please refer to the most recent applicable revision of ETSO-C113.

2 Procedures

2.1. General

The applicable procedures are detailed in Subpart A of CS-ETSO.

The data to be submitted to the European Union Aviation Safety Agency (EASA) (hereinafter referred to as 'the Agency') is defined in Subpart O of Annex I (Part 21) to Regulation (EU) No 748/2012 and in [Subpart A](#) of CS-ETSO.

2.2 Specific

Additional data which shall be submitted to the Agency by IMA modules manufacturers are specified in [Appendix 3](#), including the data required by ED-124 Task 1 (See paragraph 3.2.2.1 below).

3 Technical Conditions

3.1 Basic

3.1.1 Minimum Performance Standard

See [Appendix 2](#).

3.1.2 Environmental Standard

See CS-ETSO, [Subpart A](#), paragraph 2.1 and [Appendix 4](#).

3.1.3 Computer Software

See CS-ETSO, [Subpart A](#), paragraph 2.2.

3.1.4 Airborne Electronic Hardware

See CS-ETSO, [Subpart A](#), paragraph 2.3.

3.2 Specific

3.2.1 Failure Condition Classification

It is recognised that IMA modules may be developed independently of specific installation projects and of future hosted aircraft functions, thus preventing the possibility to define the level of the aircraft failure condition, which is out of the scope of this ETSO.

However, the module architecture and development will be driven by generic failure conditions. These can be considered as assumptions, which will contribute to determine the Development Assurance Level (DAL) allocation as per CS-ETSO [Subpart A](#), paragraph 2.4.

The assumed failure conditions and the resulting DAL are characterisation items and shall be documented in the installation manual and declaration of design and performance (DDP).

Qualitative and safety mechanisms requirements for each class are specified in the Minimum Performance Standard in [Appendix 2](#).

3.2.2 Specific Development and Installation Requirements

3.2.2.1 Development process

EUROCAE ED-124/RTCA document DO-297 ‘Integrated Modular Avionics (IMA) Development Guidance and Certification Considerations’ contains guidance for IMA developers, application developers, integrators, certification applicants, and those involved in the approval and continuing airworthiness of IMA systems in civil certification projects.

In the frame of ETSO-C153a, the development of IMA modules or platforms shall meet the objectives of the EUROCAE ED-124/RTCA document DO-297 guidance related to Task 1 (Table A-1 ‘Objectives’) except as constrained below:

Table A-1, Objective 8 is:

- applicable to a single LRU platform; and
- partially applicable to an IMA module for intrinsic validation and verification activities. (i.e. excluding 4.2.1 h).

Note: For Table A-1, Objective 8, the column ‘doc ref’ refers to 5.3 and 5.4, which provide details of objectives with applicability per Task 1 of ED-124 (See Tables 5 and 6).

3.2.2.2 Installation Considerations

An ETSO-2153 IMA module is, by definition, an incomplete system.

A definition of the activities to be performed to properly use the ETSO-C153a IMA module shall be defined for the installer. The associated test procedures to check that the authorised IMA module is properly installed shall also be documented in the installation manual in order to allow the integrator to perform integration of applications hosted on IMA platforms/modules and their installation on aircraft as per the applicable guidance.

4 Marking

4.1 General

Marking is detailed in Paragraph 1.2 of CS-ETSO, [Subpart A](#).

4.2 Specific

The part shall be permanently and legibly marked with the intended function class(es) as defined in Paragraph 1 of this ETSO. This information shall be on the ETSO nameplate or in close proximity to the nameplate.

Note: An ETSO-C153a marking does not cover IMA-hosted applications and IMA configuration management, which are software aspects not covered by this ETSO.

5 Availability of Referenced Documents

Please see paragraph 3 of CS-ETSO, [Subpart A](#).

[Amdt ETSO/10]

[Amdt ETSO/16]

Appendix 1 to ETSO-C153a – Integrated Modular Avionics (IMA) Overview, Definition and Examples

ED Decision 2020/011/R

This Appendix provides:

- Chapter 1: an overview of Integrated Modular Avionics (IMA);
- Chapter 2: applicable definitions;
- Chapter 3: a definition of the Minimum Performance Standard (MPS) classes; and
- Chapter 4: examples of IMA platforms using IMA modules.

Chapter 1: Integrated Modular Avionics overview

In this ETSO, Integrated Modular Avionics (IMA) is defined according to EUROCAE ED-124 (equivalent to the RTCA document DO-297):

Integrated modular avionics (IMA): is a shared set of flexible, reusable, and interoperable hardware and software resources that, when integrated, form a platform that provides services, designed and verified to meet a defined set of safety and performance requirements, to host applications performing aircraft functions.

The IMA architecture integrates many aircraft functions on the same platform. Those functions are provided by several hosted applications that have historically been contained in functionally and physically separated ‘boxes’ or LRUs.

IMA platforms are composed of modules which are designed to be reusable in order to reduce development costs and occasionally facilitate certification programmes. Some modules provide only mechanical, possibly cooling and electrical power supply functions. Others include core software and the associated computing capabilities.

IMA modules are usually both generic and configurable, therefore, the same platform could be used on different aircraft models.

Chapter 2 — Applicable definitions

Legend

- [ED-124]: Definitions from EUROCAE ED-124 (equivalent to RTCA document DO-297).
- [C153a]: Definitions provided or adjusted in the frame of the ETSO.

Aircraft function [ED-124]: The capability of the aircraft that may be provided by the hardware and software of the systems on the aircraft.

Application [ED-124]: Software and/or application-specific hardware with a defined set of interfaces that, when integrated with the platform, performs a function.

Cabinet [C153a]: Result of the integration of hardware modules mounted within one rack.

Characterisation item [C153a]: Identified module characteristics towards which the IMA module developer needs to determine the module performance, with full verification and documentation in the user guide/installation manual as appropriate.

Component [ED-124]: A self-contained hardware, software part, database or combination thereof that is configuration-controlled. A component does not provide an aircraft function by itself.

Configuration data [ED-124]: See Paragraph 3.7.1.

Core Software [ED-124]: The operating system and support software that manage resources to provide an environment in which applications can be executed. Core software is a necessary component of a platform and is typically comprised of one or more modules (such as, for example, libraries, drivers, kernel, data-loading, boot, etc.).

IMA Platform [ED-124]: A module or group of modules, including core software, which manage resources in a manner sufficient to support at least one application. IMA hardware resources and core software are designed and managed in a way that provides computational, communication and interface capabilities for hosting at least one application. Platforms by themselves do not provide any aircraft functionality. The IMA platform may be accepted independently of hosted applications.

IMA System [ED-124]: It consists of (an) IMA platform(s) and a defined set of hosted applications.

LRM (Line Replaceable Module) [C153a]: An IMA platform element identified in aircraft configuration and replaceable by aircraft line maintenance to restore the aircraft into an operational ready condition. An IMA LRM is a stand-alone item of equipment which does not provide any aircraft function until hosted applications are integrated.

LRU (Line Replaceable Unit) [C153a]: An element supporting an aircraft function identified in aircraft configuration and replaceable by aircraft line maintenance to restore the aircraft into an operational ready condition. An LRU is usually a stand-alone item of equipment such as a radio, a Flight Management Computer or any kind of functional equipment.

IMA Module [C153a]: A component or collection of components that may be hardware or a combination of hardware and software, which provide resources to the IMA-hosted applications. Software application and module configuration data are not covered by this definition. Modules may be distributed across the aircraft or may be co-located.

Operating System[ED-124]:

- 1) The same as executive software.
- 2) The software kernel that services only the underlying hardware platform.
- 3) Software that directs the operations of a computer, resource allocation and data management, controlling and scheduling the execution of computer-hosted applications, managing memory, storage, input/output, and communication resources.

Rack [C153a]: A physical package able to contain at least two hardware modules, which may provide partial protection from environmental effects (shielding) and may enable installation on and removal of the mounted modules from the aircraft without physically altering other aircraft systems or equipment.

Resources/Shared resources [ED-124]: Any object (processor, memory, software, data, etc.) or component used by an IMA platform or application. A resource may be shared by multiple applications or dedicated to a specific application. A resource may be physical (a hardware device) or logical (a piece of information).

Support software [C153a]: Embedded software necessary as a complement to the operating system to provide general services such as contributing to the intended function of resources sharing, handling hardware, drivers, software loading, health monitoring, boot strap, etc.

Unit [C153a]: Set of physical components (hardware and/or software) inside an item of equipment in charge of providing a resource.

Usage Domain [C153a]: The usage domain of an IMA module is defined as an exhaustive list of conditions (such as configuration settings, usage rules etc.) to be respected by the user(s) to ensure

that the IMA module continues to meet the performance characteristics and requirements of the ETSO Minimum Performance Standard. Compliance with usage domain ensures that:

- the module is compliant with its functional, performance, safety and environmental requirements specified for all implemented intended functions;
- the module characteristics documented in the User Guide (as required by Appendix 2) are guaranteed by manufacturer; and
- the module is compliant with the applicable airworthiness requirements (including continuing airworthiness aspects). (*)

(*) Note: In the context of this IMA modules/platforms ETSO standard, this last sentence refers to requirements as described in Section 2 of CS-ETSO Subpart A.

Chapter 3 — Definition of intended function classes

To apply for an ETSO-C153a authorisation, the IMA module shall comply with applicable common requirements and implement at least one Intended Function Class. If a manufacturer applies for an ETSO-C153a authorisation, all the classes for which the Intended Function is implemented shall be compliant.

CLASS RH: Rack Housing

For ETSO-C153a Class RH:

1.3.RH.1: The IMA module is a physical package able to contain at least two hardware modules that may provide protection from environmental effects (shielding, etc.) and enable the installation and removal of those module(s) from the aircraft without physically altering other aircraft systems or equipment.

1.3.RH.2: The IMA module may be a simple mechanical enclosure, or it may incorporate communication interfaces, backplanes for data and power supplies, active cooling or any combination of these features.

1.3.RH.3: The IMA module does not offer the capability to host applications unless combined with a Class PR approval.

1.3.RH.4: The IMA module may be configurable.

CLASS PR: Processing

For ETSO-C153a Class PR:

1.3.PR.1: The IMA module contains a processing component, a memory component, interface devices and the associated Core Software which constitute one or several Processing Unit(s).

Note: Containing memory components or interfaces devices does not lead automatically to having class DS and/or IF in the certification basis; DS or IF classes need to be applied for only if concurrent access to these interface or data storage resources is offered as a shared resource (as described in Class DS and IF).

1.3.PR.2: The intended function of such an IMA module is to share Processing, Data and Information between at least two hosted applications, modules and/or components.

1.3.PR.3: The IMA module offers the capability to host applications.

1.3.PR.4: The IMA module may be an association of hardware and Core Software.

- Hardware may (or may not) contain resident (not field-loadable) software to enable electronic part marking and/or future loading of Field-Loadable Software parts.
- Core Software may be resident or a Field-Loadable Software part.

1.3.PR.5: The IMA module may be configurable.

CLASS GP: Graphical Processing

For ETSO-C153a Class GP:

1.3.GP.1: The IMA module contains a graphical engine component and an optional video engine component, memories, interfaces and potentially associated Core Software which constitute one or several Graphical Unit(s).

1.3.GP.2: The intended function of such an IMA module is to share graphics and optional video signal processing between at least two hosted applications, modules and/or components.

1.3.GP.3: The IMA module does not offer the capability to host software applications unless combined with a Class PR approval.

1.3.GP.4: The IMA module may be an association of hardware and Core Software.

- Hardware may (or may not) contain resident (not field-loadable) software to enable electronic part marking and/or future loading of Field-Loadable Software parts.
- Core Software may be resident or a Field-Loadable Software part

1.3.GP.5: The IMA module may be configurable.

CLASS DS: Data Storage

For ETSO-C153a Class DS:

1.3.DS.1: The IMA module contains memory (volatile or non-volatile), an interface component and potentially associated Core Software which constitute one or several Data Storage Unit(s).

1.3.DS.2: The intended function of such an IMA module is to share stored data (e.g. databases, files, etc.) between several applications, modules and/or components.

1.3.DS.3: The IMA module does not offer the capability to host applications, unless combined with a Class PR approval.

1.3.DS.4: The IMA module may be an association of hardware and a Core Software.

- Hardware may (or may not) contain resident (not field-loadable) software to enable electronic part marking and/or future loading of Field-Loadable Software parts.
- Core Software may be resident or a Field-Loadable Software part.

1.3.DS.5: The IMA module may be configurable.

CLASS IF: Interface

For ETSO-C153a Class IF:

1.3.IF.1: The IMA module contains input/output component(s) and potentially associated Core Software which constitute one or several Interface Unit(s). These interfaces can be discrete, analogue, a serial interface, a digital bus, etc..

1.3.IF.2: The intended function of such an IMA module is to share information between several aircraft functions or applications.

1.3.IF.3: The IMA module does not offer the capability to host applications unless combined with a Class PR approval.

1.3.IF.4: The IMA module may be an association of hardware and a Core Software.

- Hardware may (or may not) contain resident (not field-loadable) software to enable electronic part marking and/or future loading of Field-Loadable Software parts.
- Core Software may be resident or a Field-Loadable Software part.

1.3.IF.5: The IMA module may be configurable.

CLASS PS: Power Supply

For ETSO-C153a Class PS:

1.3.PS.1: The IMA module contains a set of components (hardware and/or software) which constitute one or several Power Supply Unit(s) in charge of managing electric power.

1.3.PS.2: The intended function of such an IMA module installed into a rack (Class RH module) is to provide power supplied from an airborne electrical network to one or more hardware modules embedded into the same rack.

1.3.PS.3: The IMA module does not offer the capability to host applications unless combined with a Class PR approval.

1.3.PS.4: The IMA module may be configurable.

1.3.PS.5: The IMA module may be an association of hardware and a Core Software.

- Hardware may (or may not) contain resident (not field-loadable) software to enable electronic part marking and/or future loading of Field-Loadable Software parts.
- Core Software may be resident or a Field-Loadable Software part.

CLASS DH: Display Head

For ETSO-C153a Class DH:

1.3.DH.1: The IMA module contains a set of components (hardware and/or software) in charge of managing a displayed area which constitutes one or several Display Unit(s).

1.3.DH.2: The intended function of such an IMA module is to offer the capability to depict graphical information received from IMA Application(s), component(s) and/or module(s) on one Display Area.

1.3.DH.3: The IMA module does not offer the capability to host applications unless combined with a Class PR approval.

1.3.DH.4: The IMA module may be an association of hardware and a Core Software.

- Hardware may (or may not) contain resident (not field-loadable) software to enable electronic part marking and/or future loading of Field-Loadable Software parts.
- Core Software may be resident or a Field-Loadable Software part.

1.3.DH.5: The IMA module may be configurable.

Chapter 4 — Example of an IMA platform using IMA modules

EUROCAE ED-124/RTCA document DO-297 contains some examples relating to the definition of the IMA module and platform, which can be completed by some additional examples related to Chapter 3 'Definitions'.

Example 1: Single LRU platform (as per EUROCAE ED-124/RTCA document DO-297)

This example illustrates the sharing of computational and Input/Output (I/O) resources within a single Line Replaceable Unit (LRU). Such IMA system key characteristics include:

- hosting of multiple applications (not part of the IMA platform);
- platform configuration data and data loading; and
- a defined API between the IMA platform and hosted applications.

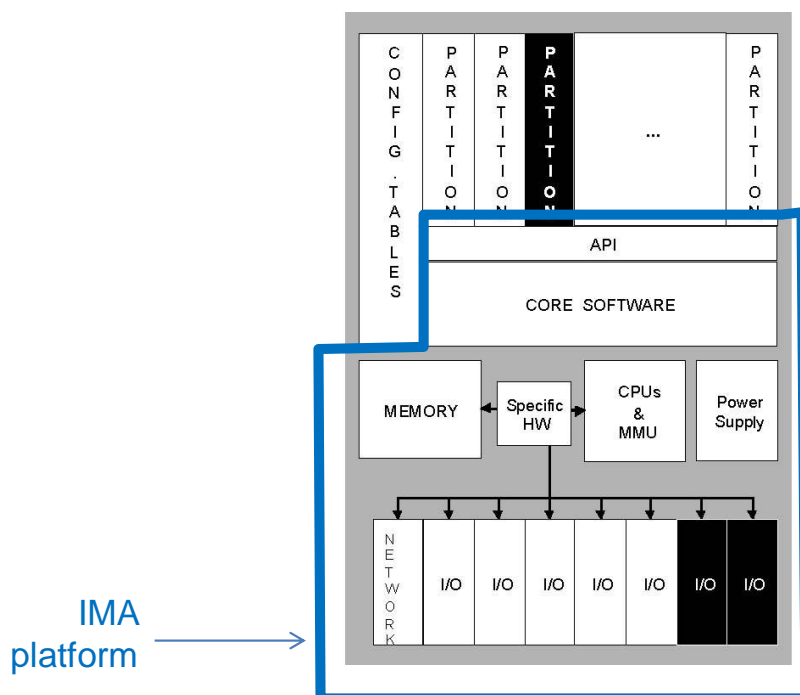

Figure 1: Single LRU platform (as per EUROCAE ED-124/RTCA DO-297)

At one level, this example illustrates a single platform providing core computational resources. At another level, it illustrates a module to be used within a larger IMA platform.

If sharing of processing, memory, and I/O resources is implemented within the LRU, such a single LRU platform will be eligible for CLASS PR, DS and IF.

Example 2: Single LRU A664 switch equipment

This example illustrates the sharing of ARINC Specification 664 I/O resources within a single Line Replaceable Unit (LRU).

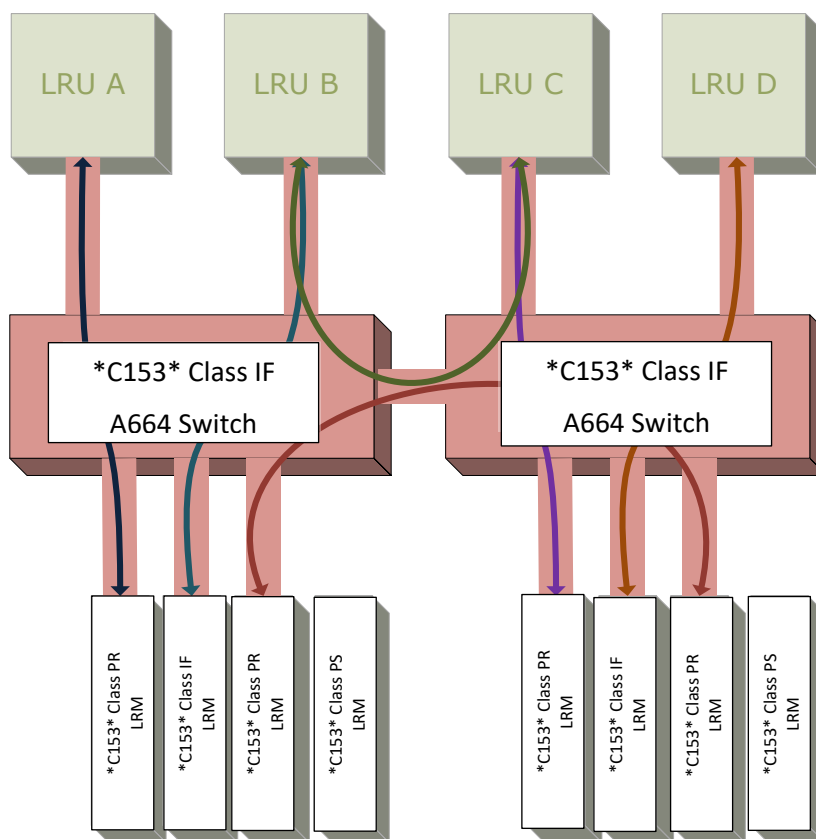

 Virtual link (see ARINC 664) between two subscribers, switched by the *C153* class IF modules

Figure 2: Example of an architecture based on two ETSO-C153** class IF modules each implementing an ARINC 664 switch**

Note: ETSO-**C153** is intended to identify any existing amendment of this ETSO including its first release as ETSO-2C153.

In this architecture, the two ETSO-C153a class IF modules switch A664 frames, providing each of the subscribers shared access to the network. Network subscribers can be other ETSO-C153a modules as the lower row of modules shows, or non-IMA equipment (top row) such as displays/radio transceivers.

If sharing of ARINC Specification 664 I/O resources is implemented within the LRU, such a single LRU platform shall be eligible for CLASS IF.

Example 3: IMA modules installed in a Rack Module (Line Replaceable Module)

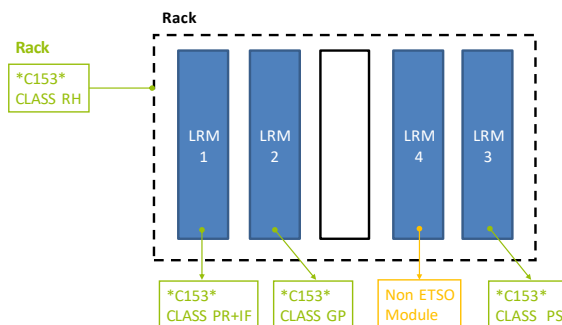

Figure 3: IMA modules installed in a Rack Module

This example illustrates the sharing of resources within several single Line Replaceable Modules (LRMs) installed in a Rack:

- a Rack is an IMA module and will be eligible for CLASS RH;
- LRM 1 provides shared Processing and Input/Output and shall be eligible for CLASS PR+IF;
- LRM 2 provides shared Graphical Processing and shall be eligible for CLASS GP;
- LRM 3 provides shared a Power Supply to LRMs embedded into the same rack, and shall be eligible for CLASS PS; and
- LRM 4 does not provide shared resources. This module shall be considered as a non-ETSO-C153a module.

All these modules are considered to be parts.

[Amdt ETSO/10]
[Amdt ETSO/16]

Appendix 2 to ETSO-C153a – Integrated Modular Avionics (IMA) Module Minimum Performance Standard (MPS)

ED Decision 2020/011/R

This Appendix provides a Specific Minimum Performance Standard for IMA modules.

Principle

An IMA module is composed of hardware components or hardware and software components performing the intended function(s) whose minimum performance requirements are specified in this Appendix.

This Minimum Performance Standard (MPS) is structured as a common-requirements section and a set of classes specifying IMA module intended functions:

- COMMON: Minimum Performance Standard applicable whatever IMA module and whatever the implemented intended function class(es);
- CLASS RH: Rack Housing intended function;
- CLASS PR: Processing intended function;
- CLASS GP: Graphical Processing intended function;
- CLASS DS: Data Storage intended function;
- CLASS IF: Interface intended function;
- CLASS PS: Power Supply intended function; and
- CLASS DH: Display Head intended function.

To apply for an ETSO-C153s authorisation, the IMA module shall comply with a common Minimum Performance Standard and implement at least one Intended Function Class as defined in this Appendix.

When applying for an ETSO-C153a authorisation, the applicant shall include in the certification basis all classes for which the intended function is implemented in the IMA module/platform.

Naming convention

This document contains ‘shall’, ‘should’ and ‘may’ statements with the following meanings:

- the use of word ‘shall’ indicates a mandated criterion, i.e. compliance with the criterion is mandatory and no alternative may be applied;
- the use of word ‘should’ (and phrases such as ‘It is recommended that...’, etc.) indicate that though the procedure or criterion is regarded as the preferred option, alternative procedures, specifications or criteria may be applied, provided that the manufacturer, installer or tester can provide information or data to adequately support and justify the alternative;
- the use of word ‘may’ indicates that though the criterion is regarded as the preferred option, alternative criteria may be applied. In such cases, alternatives should be identified in appropriate approval plans and agreement sought from the approval authority.

Verification Procedures

For verification procedures, the following definitions and symbols are used in this Appendix:

Analysis (A)

Analysis is the method of verification which consists in comparing design with known scientific and technical principles, technical data, or procedures and practices to validate that the proposed design will meet the specified functional or performance requirements.

Demonstration (D)

Demonstration is the method of verification where qualitative versus quantitative validation of a requirement is made during a dynamic test of the system/equipment. In general, software functional requirements are verified by demonstration since their functionality must be observed through some secondary media.

Inspection (I)

Inspection is the method of verification to determine compliance with requirements and consists primarily of visual observations or mechanical measurements of the system/equipment, physical location, or technical examination of the engineering support documentation.

Test (T)

Test is the method of verification that will exercise equipment functions and measure system/equipment performance under a specific configuration and load conditions and after the controlled application of known stimuli. Quantitative values are measured, compared against previously predicated success criteria, and then evaluated to determine the degree of compliance.

Y

The test is mandated under the indicated conditions.

m/n

Either verification method 'm' or verification method 'n' may be used to verify the requirement (i.e. D/A can be verified by Demonstration or Analysis).

m+n

Both verification methods must be used to verify the requirement (i.e. D+A means that the requirement must be verified by Demonstration and Analysis).

[Amdt ETSO/10]

Appendix 2.1 to ETSO-C153a – Integrated Modular Avionics (IMA) Module Minimum Performance Standard (MPS)

ED Decision 2020/011/R

COMMON: Applicable to all IMA modules

1. Purpose and scope

This Appendix contains a set of Minimum Performance Standards (MPS) applicable to any IMA module and to any implemented intended function class(es).

In the following, the term ‘concurrent items’ designates the items (applications, for example) that use the shared resource of the IMA module. Depending on the module class, it means ‘processing element’ for PR class, ‘thread’ for GP, IF and DH class, ‘data storage element’ for DS class, and ‘power rail’ for PS class.

2. Requirements

2.1. Functional requirements common to all classes

CO.a) The IMA shall implement at least one Function Class.

The following requirements of this paragraph are applicable to all classes with some exception as described below:

CO.b) Except for the housing function (F1) of class RH (see Appendix 2.2, paragraph 2.1.1), the IMA module shall provide at least the following control features to react to detected failures:

- a. disable, and
- b. reset.

CO.c) Except for the Housing function (F1) of class RH (see Appendix 2.2, paragraph 2.1.1), each IMA module shall provide a health management and reporting capability.

CO.d) Except for the housing function (F1) of class RH (see Appendix 2.2, paragraph 2.1.1), the health management and reporting function shall detect, isolate, contain and report faults (in the shared resources and other resources) that could adversely affect applications using the module resources or the resources themselves.

CO.e) Except for class RH, robust partitioning (as per EUROCAE ED-124/RTCA DO-297) between ‘concurrent items’ sharing the resource shall be ensured by the IMA module.

CO.f) Except for class RH, robust partitioning shall not rely on any required behaviour of any aircraft function or hosted application (as per EUROCAE ED-124/RTCA DO-297, Section 3.5c).

CO.g) Except for class RH, the potential breaches in robust partitioning shall be identified. An appropriate process and means should be implemented to ensure that such failures which result or may result in an unsafe condition are detected and reported.

CO.h) Except for class RH, the IMA module shall implement a fault containment mechanism to prevent fault propagation between ‘concurrent items’ using the shared-resource elements and between other IMA modules.

CO.i) Reserved.

CO.j) Except for the housing function (F1) of class RH (see Appendix 2.2, paragraph 2.1.1), the interface between the ‘concurrent items’ and the shared resource should conform to the characteristics as described by a standard (ARINC specifications 653, 664, and 600, for example).

2.2. Characterisation requirements

CO.k) Each item of the characterisation shall be documented in the User Guide/Installation Manual as appropriate.

CO.l) The IMA module specification shall be characterised based on items in the table below (Figure 4: IMA module Characterisation Categories) and on the characterisation requirements identifying additional characterisation items specific to each functional class (defined in Appendix 2 — Class RH, PR, GP, DS, IF, PS, and DH).

CO.m) Quantifiable characterised items shall be quantified in terms of minimum, typical (when relevant) and maximum values and the associated accuracy.

Note: The influence of environmental or abnormal conditions should be considered when relevant.

CO.n) The characterisation of the IMA module shall be correct and complete. Completeness is achieved when all the shared features of the IMA module have been characterised.

CO.o) The characterisation shall identify the valid usage domain of the IMA module.

CO.p) The characterisation shall provide all constraints on the usage domain and on the installation (including limitations and activities) to be respected by the users.

CO.q) The characterisation shall provide the list of types of shared-resource elements, the associated attributes, their configurability and their performances, and their associated limit of use.

CO.r) The characterisation shall include at least the following characteristics of the core software/programmable hardware:

- a. the identification of the core software component(s)/programmable hardware (if any);
- b. the IMA module functionality, performance and safety requirements supported by the core software/programmable hardware;
- c. external interfaces and associated data coupling/control-coupling information;
- d. integration and loading procedure(s); and
- e. the development assurance level(s).

CO.s) When the IMA module offers the capability to host software, the characterisation shall provide any data needed to evaluate the worst-case execution time (WCET) of each concurrent item sharing the IMA module resource.

CO.t) The performances of each shared-resource management mechanism including monitoring shall be characterised, in particular the range, timing aspects, transients, etc..

- CO.u) For at least the following failure modes, the failure rate shall be provided:
- a loss of the IMA module;
 - erroneous behaviour of the IMA module;
 - a loss of the shared-resource element; and
 - erroneous behaviour of the shared-resource element.
- CO.v) The characterisation shall include the monitoring coverage rate (PBIT, CBIT, etc.) for the identified failure modes of the IMA module (including shared and unshared resources, sharing mechanisms and robust partitioning mechanisms).
- CO.w) The characterisation shall address the safety aspects of bad sequencing, delay, corruption and impersonation, where applicable.
- CO.x) The following health monitoring items shall be included in the characterisation:
- interface rules, constraints (including limitations) to be respected by the users;
 - list of Health Monitoring services;
 - list of monitored components, monitored services, monitored interfaces;
 - response to each type of fault;
 - fault reporting attributes (reporting refers to internal logging, indication to applications using the shared resources, indication outside of the module); and
 - the configuration attributes, if any.
- CO.y) If the IMA module is configurable, the characterisation shall include, in addition, the following items:
- the authorised configuration parameters (including range, type and definition of combined parameters) in the usage domain; and
 - the configuration activities to be conducted (including configuration procedures, means and tools) by the user during application development (EUROCAE ED-124 — Task 2) and IMA system integration (EUROCAE ED-124 — Task 3 and 4).
- CO.z) If some tools are required for installation, these tools shall be characterised according to the following:
- identification;
 - the user's manuals of the tools;
 - the activities related to those tools to be conducted during application development (EUROCAE ED-124 — Task 2) and IMA system integration (EUROCAE ED-124 — Task 3 and 4);
 - the proposed associated qualification credits that could be granted to the user of the tools;
 - the category of the tool and the Development Assurance Level of the tool (if any) as defined in the applicable Software Development assurance guidance (see Section 2.2 of CS-ETSO, Subpart A,); and

- f. limitations and Open Problem Report (if any) on tools that could affect the tool qualification credit and require analysis by the user.

CO.aa) The compatibility and mixability information between hardware, software, tools and usage domain shall be part of the characterisation. This characterisation shall address at least the following:

- a. how the authorised mixed combinations are verified;
- b. the compatibility assessment process with authorised mixed combinations of interfacing modules (external mixability);
- c. any preventative measures (design or procedures) to be developed by the user to prevent incorrect module combinations or software loads; and
- d. information to be provided to maintenance personnel.

CO.bb) The control features (disable, reset, reload, etc.) of the IMA module for reacting to detected failures shall be characterised.

Characterisation Category	Characterisation item
General Information	Power Dissipation
	Thermal characteristics
	Temperature control (e.g. cooling) characteristics
	Size and Weight
	Input and Output (I/O) Connectors (including pinout)
	Mating Connectors
	Top-level drawings and Mechanical Interfaces
	Mounting Mechanism and scheme
	Clearance characteristics
	Air Flow characteristics
	Inter-Element Interfaces (such as Backplane interface)
	Grounding and Shielding Provisions
	Separation and/or Isolation Provisions
	Module Installation and Extraction Means
	Backplane Interface
	Start-up sequence
	Different operational modes (initialisation, monitor, operational etc.)
	Interfaces
Type of Analogue (e.g. differential, isolated, etc.)	
Range	
Accuracy	
Resolution	
Null and Offset	
Filtering	
Input Impedance	
Analogue-to-Digital Conversion Speed	
Steady-State Voltage Rating	
Transient Voltage Rating	

Characterisation Category	Characterisation item
	Circuit Protection Techniques
	Multiplexing
	Latency Time
	Bandwidth
	Analogue Output Specifications For Each Analogue Output
	Type of Analogue (e.g. differential, isolated, etc.)
	Range
	Accuracy
	Null
	Linearity
	Current Capacity
	Output Impedance
	Steady-State Voltage Rating
	Transient Voltage Rating
	Circuit Protection Techniques
	Multiplexing
	Latency Time
	Bandwidth
	Discrete Input Specifications For Each Discrete Input
	Trip Point
	Hysteresis
	Filtering
	Input Impedance
	Logic Sense
	Maximum Logic–High Level
	Maximum Logic–Low Level
	Minimum Logic–High Level
	Minimum Logic–Low Level
	Steady-State Voltage Rating
	Transient Voltage Rating
	Circuit Protection Techniques
	Multiplexing
	Discrete Output Specifications For Each Discrete Output
	Voltage Levels
	Current Source Capacity
	Current Sink Capacity
	Output Impedance
	Circuit Protection Techniques
	Multiplexing
	Digital Communications For Each Input and Output
	Data Rates
	Integrity Checks
Signal Levels	
Current Sink and Source	
Input Impedance	

Characterisation Category	Characterisation item
	Output Impedance
	Signal Rise and Fall Times
	Filtering
	Stub Length Limits
	Input and Output Capacitance
	Isolation
	Maximum Bit Error Rates
	Circuit Protection Techniques
	Resets
	Monitors
Multiplexing	
Processing and Memory (inc. Graphical)	Included Software Services (Core Software) and associated performances: Data loading, Health Management, Operating System
	Processing Unit (CPU, GPU, etc.), Component(s), Bus(es) and Core Clock Frequencies
	Memory Size(s), Type(s), Control of Access and Timing(s)
	Local data bus(es) Type(s) and Timings
	Start-up and Reset mechanisms and timings
Display and Rendering	Refer to SAE AS8034 'Minimum Performance Standard for Airborne Multipurpose Electronic Displays' (revision as defined in the applicable release of ETSO-C113)
Power Supply	Regulation
	Input Voltage and Current range
	Maximum Start-up (Input and Output Inrush) Current Rating
	Hold-up Capacity
	Restart
	Transient Immunity
	Short Circuit Management
	Power Resets and Recovery
	Circuit Protection Techniques
Slew rate at start-up	

Figure 4: IMA module Characterisation Categories

The following list of terms summarises the terminology used in the characterisation items defined in Figure 4 that are applicable to this ETSO, in the development of hardware elements, and in the application of the Appendix 1 MPS development criteria. The terms are segregated into eight categories according to the performance of the appropriate hardware element.

(1) General Terms

Air Flow Characteristic: specific requirements to provide air movement into or onto a cabinet, LRU, or module (e.g. air temperature, volume rate, and pressure).

Analogue/Digital Conversion Speed: the time to perform one Analogue-to-Digital (A-to-D) conversion. Typically, this is expressed as either the time for one analogue conversion performed by the A/D converter device or the frequency at which all analogue inputs are converted.

Circuit Protection Techniques: the electrical isolation or circuitry included in inputs or outputs to protect the functional circuits from external environments (for example solutions to protect circuits from the indirect effects of lightning).

Current Source/Sink: the maximum current drawn by the output while pulling the signal to a zero-volt (ground) level.

Current Source: the maximum current supplied by the output while driving the signal to a voltage level.

Clearance Characteristics: additional spacing requirements in specific directions from the cabinet or rack beyond the outline dimensions (e.g. additional clearance is the area to allow proper airflow).

Design Assurance: all planned and systematic actions and data used to substantiate that hardware correctly performs its intended function(s) and that design errors have been identified and corrected such that the hardware satisfies the applicable certification basis.

Development Assurance: all planned and systematic actions and data used to substantiate that the system performs its intended function(s) and that development errors have been identified and corrected such that the system satisfies the applicable certification basis.

Functional Software: software applications that will be approved as part of a functional TSO authorisation or as part of a type certification effort. This software is sometimes referred to as operational software, application software, or flight software.

Functional ETSO: an ETSO with defined functionality (for example, Airborne Weather Radar, ETSO-C63). ETSO-C153a is not considered a functional ETSO, because IMA hardware elements typically do not have system-level functionality.

Grounding/Shielding Provisions: the electrical and/or mechanical details of the design which provide grounding of the element or shield connections. These are the design details usually associated with the Radio Frequency emission and susceptibility protection of the system.

Hardware element: in this ETSO, a hardware element is (1) a hardware module, or (2) cabinets or racks that host hardware modules.

Note: This definition may differ from the terminology used in other documents (e.g. ED-80/RTCA DO-254).

Inter-Element Connections: the connector type specification and connector pin assignments specified to allow modules to be installed interchangeably in the cabinets or racks.

Inter-Element Interfaces: the definition of the electrical signals, timing requirements, and protocols used to communicate among modules or elements with the cabinet or system.

Module Extraction Means: the details of the mechanical design to enable removal of the module from the cabinet.

Module Mounting Scheme: the details of the mechanical design used to secure each module into the cabinet or rack.

Mounting Mechanism: the details of the mechanical mechanism(s) used to secure the module into the cabinet or rack of the aircraft.

Multiplexing: the design technique where multiple inputs are individually switched to one receiver (for example, multiple digital communication buses switched to a serial receiver) or multiple outputs are individually supplied by the same circuit (for example, multiple analogue outputs driven by one Digital-to-Analogue converter through multiple sample-and-hold).

Separation/Isolation Provisions: the electrical and/or mechanical details of the design which provide physical or electrical means of reducing interference from one element to another.

Steady State Voltage Rating: the maximum voltage range that can be applied continuously to an input or output without resulting in damage.

Transient Voltage Rating: the maximum voltage that can be applied for a short period of time to an input or output without resulting in damage. The maximum duration of the transient must be included.

(2) Analogue Input/Output Terms

Accuracy: the degree of conformity to the true value of the signal. This is usually expressed as a percentage of the reading or a percentage of the full-scale value of the signal.

Current Capacity: the maximum amount of current that can be sunk or sourced by the circuit.

Linearity: the error from the directly proportional expected signal value as the signal values vary over the entire range.

Null: the signal value(s) for which a value of zero is identified. This is usually shown as positive and negative voltage values.

Offset: the indicated signal value (usually non-zero) when zero volts are applied.

Range: the least and greatest operating voltage extremes (full scale) of the signal; the voltage extremes between which the signal value is valid.

Resolution: the smallest measurable division of the numerical expression of the signal. This is usually identified as the number of binary bits used to express the signal value and/or the value in volts of the least significant binary bit (LSB).

(3) Discrete Input/Output Terms

Discrete Input: this is an input with only two states. Typical examples are ‘ground or open’ and ‘28-volt and open’ inputs.

Discrete Output: this is an output with only two states. Typical examples are ‘ground or open’ and ‘28-volt and open’ outputs.

(4) Input Terms

Hysteresis: the value of the input voltage lag when changing states. For example, if an input circuit has 0.2 volts of hysteresis and if the trip point is 2.0 volts, then the circuit will change state as the input voltage reaches 2.0 volts but will not revert back to the original state until the input voltage drops below 1.8 volts.

Logic Sense: this is the functional interpretation of the discrete input states. A true or positive logic sense may identify the ‘ground’ state as ‘low’ or binary ‘0’. An inverse or negative logic sense may identify a ‘ground’ state as ‘high’ or binary ‘1’.

Maximum Logic–High Level: the largest voltage value that can be applied to the input and that the circuit will interpret as ‘high’.

Maximum Logic–Low Level: the largest voltage value that can be applied to the input and that the circuit will interpret as ‘low’.

Minimum Logic–High Level: the smallest voltage value that can be applied to the input and that the circuit will interpret as ‘high’.

Minimum Logic–Low Level: the smallest voltage value that can be applied to the input and that the circuit will interpret as ‘low’.

Trip Point: this is the input voltage value at which the input circuitry changes state.

(5) Output Terms

Current Sink Capacity: the maximum current by the output while pulling the signal to a zero-volt (ground) level (current flowing in the direction from the load to the element output).

Current Source Capacity: the maximum current supplied by the output while driving the signal to a voltage level (current flowing from the element output to the load).

Voltage Levels: the minimum and maximum voltages for each state of the output. The ground point that is to be used as reference must be identified.

(6) Processor Terms

Backplane Interface: the definition of the electrical signals, buses, timing requirements, and protocols used to communicate among elements installed in a cabinet or rack.

Interrupts: the signals to the processor that stops execution of an ongoing process or application. These signals indicate that there is a higher priority request of task or that an asynchronous event is occurring.

Memory Management Unit: a specialised control circuitry, sometimes integrated within the microprocessor, which performs predictive reads of instruction (prefetch) for use by the processor. It also may perform structured or prioritised control of specific sections of the memory.

Monitors: specific circuits which observe the normal operation of the processing system and alert the processor or user to an abnormal condition. Examples are power supply

monitors, which reset the processor when a voltage is outside of its tolerance, and activity monitors, which reset the processor when the processor does not perform a prescribed sequence.

Reset Structure: the architectural details of the various signals that stop execution of an ongoing process, or software application and restarts the processor at a known state.

Central Processing Unit (CPU) Throughput: a measure of the number of processor instructions performed by the CPU per unit of time.

(7) Power Supply Terms

Hold-up Capacity: the capacity of the power supply to continue supplying output current after the input voltage drops below the minimum level. This is usually expressed as the time from the input voltage drop to the reset generated by the power supply.

Input Voltage & Current: the input voltage is specified as nominal and acceptable variation values. The input current is specified as maximum steady state current. For the peak current, please see the term 'Maximum Start-up (Inrush) Current Rating' below.

Maximum Start-up (Inrush) Current Rating: the maximum input current when the power supply first becomes active as a result of the input voltage increase to the minimum level.

Output Current Capacity: the continuously operating maximum current supplied for each output voltage.

Power Monitors & Status Outputs: separate circuitry which checks the output voltage levels and current loading of the power supply. This circuitry will generate one or more binary signals that may be connected to the processor to alert it to the 'out of spec' condition. These binary signals may also force the power supply to shut down to prevent damage to power supply components.

Power Resets: a binary signal output from the power supply that is asserted when the output voltages are outside acceptable tolerances.

Regulation: the percentage of variation of the output voltages when subjected to changes in load, changes in temperature, and all input voltage transients and deviations.

Restart: the ability of the power supply or other circuit to return to the normal operating mode when the input voltage returns to or above the minimum level or when the tripped monitor indicates that the 'out-of-spec' condition has ended and the operating condition is returned to normal.

Short Circuit Management: the circuitry that monitors for short circuits or overcurrent conditions in the power supply outputs. The results from this circuitry may shut down the affected output or the entire power supply.

Transient Immunity: the ability of the power supply to continue operating normally during variations in the input voltage. This is usually expressed as the length of time and voltage level of the transient.

Voltage Outputs & Tolerances: the voltage levels and tolerances of the outputs produced by the power supply.

(8) Digital Communication Terms

Data Rates: the number of data bits transmitted in a time period. This is usually expressed in thousands of bits per second (Kbps) or millions of bits per second (Mbps).

Integrity Checks: the process that uses additional data accompanying the message information to validate that the message data was received without corruption or contamination. Examples are parity checks, checksums, data validity checks, and cyclic redundancy checks.

Maximum Bit Error Rates: the largest number of bit errors allowed in a message transmission before the receiver invalidates its ability to receive data from that source.

Monitors: separate circuitry that checks either the continuing operation of a transmitter, or that the receiver responds to input data. This circuitry will generate one or more binary signals that may be connected to the processor, alerting it to the 'failed' condition.

Resets: conditions that result in the receiver or transmitter stopping operation, clearing all data, and restarting.

Signal Levels: the minimum and maximum voltages for each state of the input or output. Typically, tolerances, thresholds, and the reference ground point are also identified.

Signal Rise and Fall Times: the signal rise time is the time for the output to transition from 10 % to 90 % of the amplitude. The signal fall time is the time for the output to transition from the 90 % to the 10 % level.

Stub Length Limits: the minimum and maximum length requirements of the wiring connector from the main bus to the inputs of the element.

3. Verification requirements

CO.cc) Each requirement shall be verified.

CO.dd) Each characterisation item of IMA modules and functions, their associated attributes, their configurability and their performances shall be verified commensurately to the Development Assurance Level.

CO.ee) Each characterisation item of the IMA module shall be verified over the usage domain.

CO.ff) A set of verification procedures to demonstrate the compliance of the IMA module with the applicable MPS shall be developed and proposed as part of the certification data package.

CO.gg) There is a distinction between demonstrating the capability of sharing and demonstrating the performance of that sharing function. When demonstrating the performance of the IMA module, a subset of the characterisation items that allows the behaviour of the complete IMA module during environmental testing shall be defined and submitted together with the Qualification Test Plan.

Note that this functional subset should be detailed enough to sufficiently cover the performance of the complete IMA module.

4. Test Software representativeness

When embedded software is needed to test the IMA module, this module is authorised without the functional software (hosted applications) being installed and operating.

CO.hh) Engineering analysis performed by the design holder shall determine that the test software (not the target functional software) is representative of the overall usage domain envelope of the module and related to the verification procedures.

5. Verification procedures

The following table provides verification methods for each requirement; nevertheless, an alternative method may be proposed to the certification authority.

Requirement identifier	Verification method	Test under normal conditions	Test Functional Subset ⁽¹⁾ under environmental conditions	Comment
CO.a)	I			
CO.b)	T	Y		
CO.c)	A			
CO.d)	T(A*)	Y	Y	
CO.e)	T(A*)	Y		
CO.f)	A			
CO.g)	T	Y		
CO.h)	T(A*)	Y		
CO.i)	A			Reserved
CO.j)	T(A*)	Y		
CO.k)	I			
CO.l)	A			
CO.m)	A			
CO.n)	A			
CO.o)	T(A*)		Y ⁽²⁾	
CO.p)	A			
CO.q)	I			
CO.r)	I			
CO.s)	A			
CO.t)	A			
CO.u)	I+A			
CO.v)	I+A			
CO.w)	I+A			
CO.x)	A			
CO.y)	A			
CO.z)	A			
CO.aa)	A			
CO.bb)	A			
CO.cc)	I+A			
CO.dd)	T(A*)	Y	Y	
CO.ee)	T(A*)	Y	Y	
CO.ff)	A			
CO.gg)	A			
CO.hh)	A			

Table 1: Verification Acceptance Criteria

(A*) means that verification by the Analysis method is possible for items that cannot be tested.

Note (1): applicable for a functional subset as defined in CO.gg).

Note (2): the Usage Domain has to be taken into consideration during Environmental Qualification Testing in order to evaluate the robustness of the IMA module over the full Usage Domain (see Appendix 4, Chapter 1).

[Amdt ETSO/10]

[Amdt ETSO/16]

Appendix 2.2 to ETSO-C153a – Integrated Modular Avionics (IMA) Platform and Module Minimum Performance Standard (MPS)

ED Decision 2020/011/R

CLASS RH: Rack Housing

1. Purpose and scope

1.1. Introduction

This Appendix contains the Minimum Performance Standards (MPS) for the CLASS RH Intended Function: Rack Housing.

These standards specify module characteristics that should be useful to designers, manufacturers, installers and users of the IMA module.

1.2. Definitions

For ETSO-C153a CLASS RH, the IMA module is a physical package able to contain at least two hardware modules, which may provide partial protection from environmental effects (shielding, etc.) and enable the installation and removal of those module(s) from the aircraft without physically altering other aircraft systems or equipment.

These IMA modules may be simple mechanical enclosures, or they may incorporate passive communication interfaces, a passive interconnection of data and power, an active or passive cooling unit or any combination of these features.

The following definitions are used:

- ‘Mounted’ refers to another hardware module, installed and fixed inside the IMA rack module, after a human operation.
- ‘Slot’ is a physical space inside the rack module, allocated to one hardware module.

These definitions are independent of the design choices made by the IMA module manufacturer.

Note:

- The IMA module compliant with ETSO-C153a CLASS RH MPS is only relevant in the case of an IMA platform architecture that uses a cabinet; and
- hardware modules mounted inside the Rack Housing will themselves be IMA modules (compliant with ETSO-C153a MPS classes other than RH) or non-IMA modules (i.e. non-IMA application specific hardware).

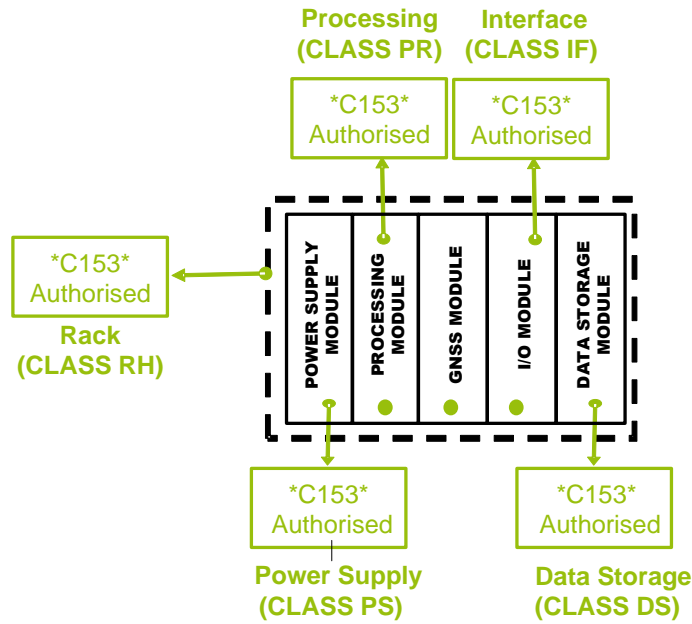

Figure 5: Illustration of the IMA platform architecture based on a cabinet

1.3. Intended Function

For ETSO-C153a CLASS RH, the intended function is to provide the capability to share some of the housing services supplied by one mechanical unit.

This intended function can be divided into 4 sub-functions:

- F1: Housing (mandatory);
- F2: Shielding (optional);
- F3: Interconnection (optional); and
- F4: Temperature control (optional).

Figure 6 provides an overview of the above-mentioned intended functions and definitions of the Rack Housing Module.

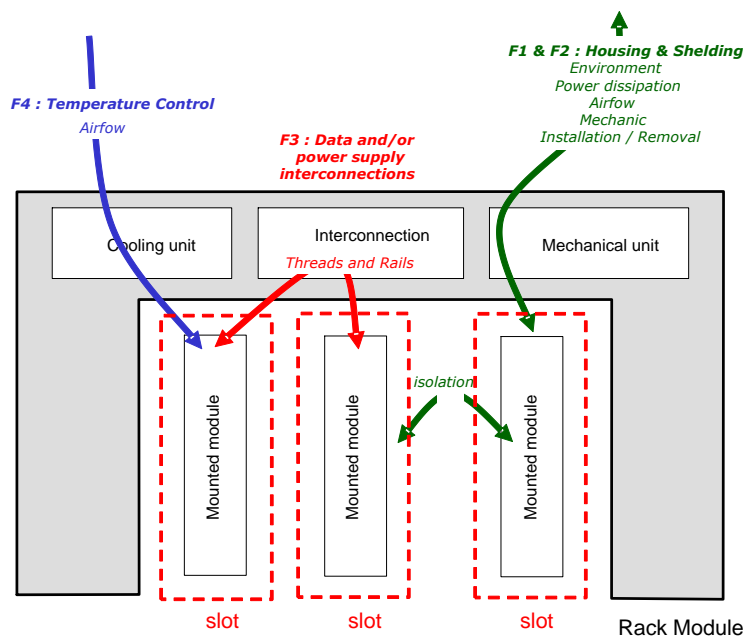

Figure 6: IMA module overview for ETSO-C153a CLASS RH

2. Requirements

2.1. Requirements for Housing (F1)

For ETSO-C153a CLASS RH, the IMA module provides shared resources for the housing needs of hardware modules. This sub-function merges:

- the capacity to host at least two hardware modules in at least two slots; and
- the capacity to mount and dismount a hardware module in its slot directly on the aircraft thanks to a human (potentially tooled) intervention.

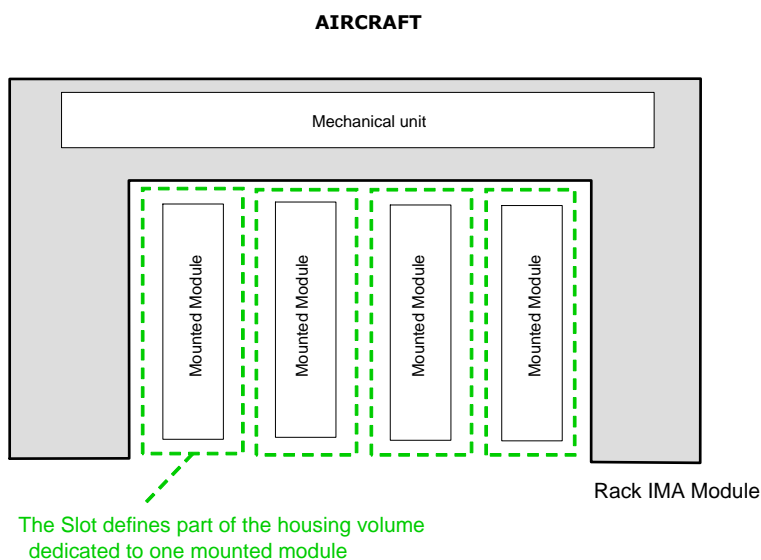

2.1.1. Functional requirements for ETSO-C153a CLASS RH (F1): Housing

- RH.a) The Rack Housing shall permit the installation and attachment of at least two hardware modules to be installed and attached, one of which (at least) is an IMA module, inside its mechanical structure.
- RH.b) The Rack Housing shall ensure the physical partitioning between the different mounted hardware modules.
- RH.c) For each type of slot, a means to avoid the installation of unintended hardware modules or inappropriate installation shall be implemented (e.g. a mechanical key).
- RH.d) If compliance with the MPS requires any additional mechanical component, then if this component is separable, it shall be marked with its part number.
- RH.e) The external mechanical interface(s) of the Rack Housing module should conform to the characteristics as described by a standard (e.g. ARINC 600). Some characteristics of the slots may be configurable.

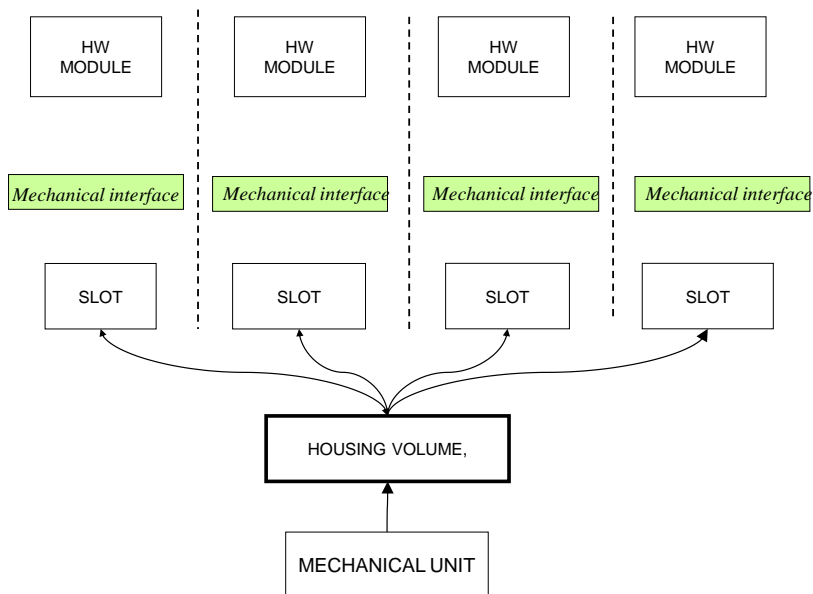

Figure 8: CLASS RH— the relationship between housing elements

2.1.2. Characterisation requirements for ETSO-C153a CLASS RH (F1): Housing

RH.f) The following housing performances or housing characteristics of the rack module shall be provided as part of the characterisation:

1. the size, mass and centre of gravity;
2. the clearance scheme;
3. the top-level drawings and mechanical interfaces;
4. the module mounting scheme;
5. the installation and extraction mechanisms;
6. the temperature control (e.g. airflow, cooling, etc.) performances if the function is implemented;
7. a list of the slots and their associated performances (physical scheme, temperature profile, connector, etc.).

Note: These characterisation requirements are additional to those applicable in Appendix 2.1 — COMMON).

RH.g) The characterisation shall include the description of the mounted hardware module installation and the extraction means and methods.

RH.h) The characterisation shall provide the list of types of slots, their associated attributes, their configurability (if any) and their sizing dimensions (drawings).

This characterisation shall include:

1. the list of authorised or predefined hardware modules (if any);
2. the list of minimum requirements that a hardware module shall comply with to be able to be inserted into the rack;

3. the slot mounting scheme (mechanical profile/drawings) and characteristics (torque, maximum number of insertions, etc.); and
4. the power dissipation and airflow profile.

RH.i) The characterisation, including the usage domain, shall be sufficiently accurate to permit specification and validation of the expected performance of the mounted hardware module.

RH.j) The characterisation shall include the configuration, weight and geometric data that are needed to evaluate the mass and centre of gravity of a populated rack and a partly populated rack.

RH.k) The characterisation shall include the installation instructions of the additional mechanical component that is necessary in order to be compliant with the MPS.

2.2. Requirements for Shielding (F2)

F2 is an optional sub-function of ETSO-C153a CLASS RH.

In this case, the IMA module provides shared resources in terms of the protection of mounted hardware modules. This sub-function merges:

- a level of protection of the mounted hardware modules from the aircraft environment (including, but not only, High Intensity Radiated Fields (HIRF) and Lightning effects); and
- a level of environmental isolation (shielding) between the mounted hardware modules inside the rack.

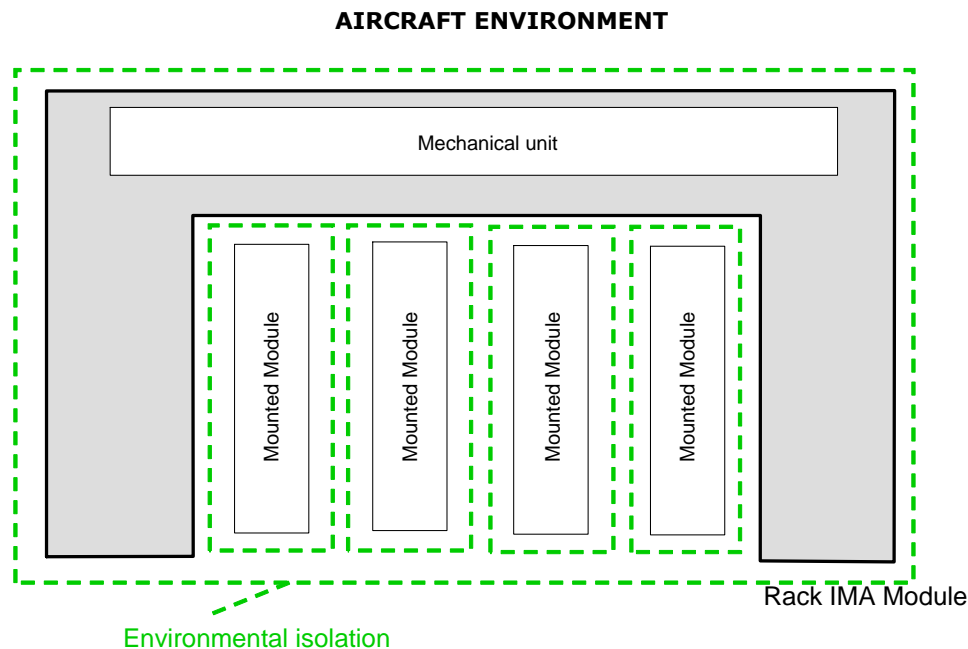

Figure 9: CLASS RH shielding function overview

2.2.1. Functional requirements for ETSO-aC153a CLASS RH (F2): Shielding

RH.l) A level of environmental protection (shielding) for each mounted hardware module shall be ensured by the Rack Housing IMA Module. This protection shall take into account the level and severity retained for the EUROCAE ED-14/RTCA DO-160 qualification of the IMA module (see Appendix 4) (outside

the rack), as well as the interactions between the mounted hardware modules themselves (inside the rack).

RH.m) The protection performance of the IMA module (Rack module) shall be quantified and guaranteed for each slot and for each EUROCAE ED-14/RTCA DO-160 Section.

RH.n) Reserved

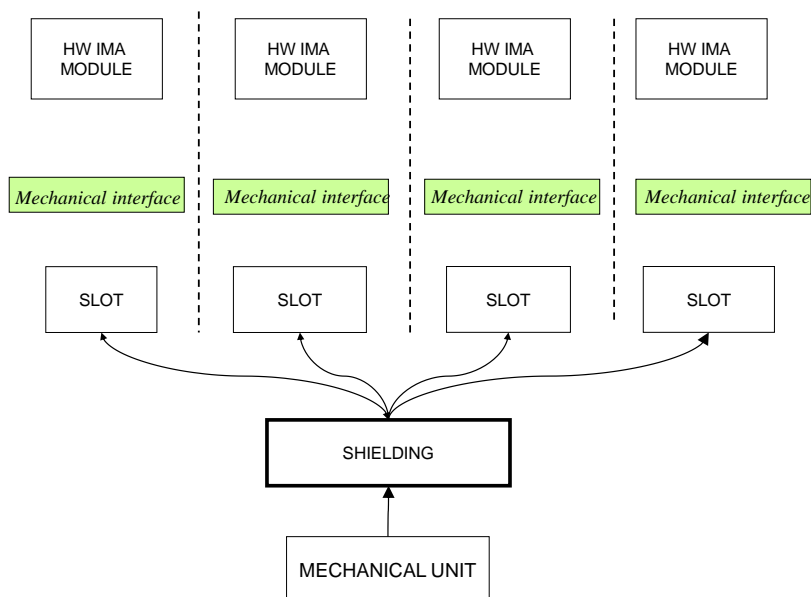

Figure 10: CLASS RH— the relationship between shielding elements

2.2.2. Characterisation requirements for ETSO-C153a CLASS RH (F2): Shielding

RH.o) The level of environmental protection (shielding) of each slot provided in Appendix 2.2, paragraph 2.1.1 shall be characterised, bounded and documented in the installation manual.

RH.p) The characterisation shall include the failure modes and rates of the protection features (such as lightning protections, etc.) to support the IMA system Safety Analysis (as per EUROCAE ED-124) at installation.

RH.q) The characterisation shall include the list of types of slots and the associated characteristics in terms of environmental protection (shielding).

This shall include:

1. the list of authorised or predefined hardware modules (if any);
2. the list of minimum requirements that a hardware module shall comply with in order to be mounted into the rack;
3. a slot Mounting Scheme (mechanical profile/isolation/drawings); and
4. the level of isolation and level of shielding per slot for each EUROCAE ED-14/RTCA DO-160 Section.

RH.r) The characterisation shall include the list of environmental tests that are used to qualify the hardware module (see Environmental Qualification Testing (EQT) in Appendix 4) mounted into the rack.

RH.s) The characterisation shall include all the possible configurations allowed for the configurable slot.

RH.t) If the RH.l) shielding objective is met thanks to any additional mechanical element(s), its installation shall be specified in the installation manual.

2.3. Requirements for Interconnection (F3)

F3 is an optional sub-function of ETSO-C153a CLASS RH.

In this case, the IMA module provides the capacity to interconnect hardware modules with each other inside the Rack Module. This interconnection allows the exchange of data or the distribution of power.

Note: To ensure the distribution of power to the mounted hardware modules, at least one ETSO-C153a CLASS PS module may be mounted into a slot to deliver electrical energy to the other hardware modules.

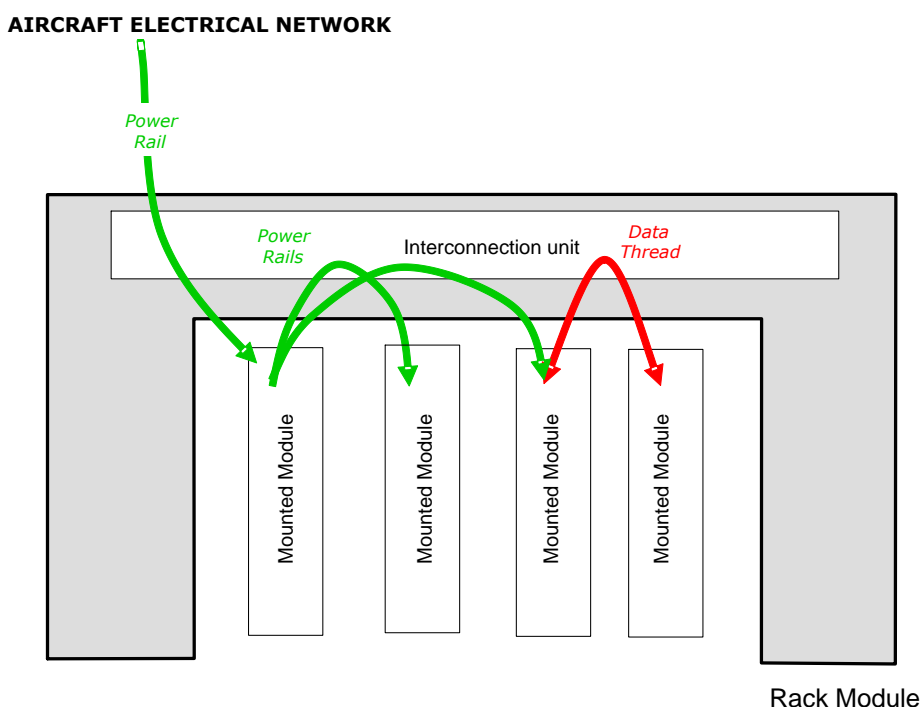

Figure 11: CLASS RH Interconnection function overview

2.3.1. Functional requirements for ETSO-C153a CLASS RH (F3): Interconnection

RH.u) The IMA module shall provide the capacity to interconnect mounted hardware modules thanks to data or power supply buses available through (an) electrical interface(s) supplied by one or several interconnection unit(s). These buses shall be dedicated to:

- a. data exchanges; and
- b. power distribution.

RH.v) If the IMA module provides more than one bus, the isolation between the buses used by mounted hardware modules shall be ensured by the IMA module. This isolation shall be substantiated by a Partitioning Analysis and by Environmental Qualification Testing.

RH.w) The interface(s) of the IMA module should conform to the characteristics as described by a standard (e.g. ARINC 600 or ARINC 664).

RH.x) The data and power supply buses shall not degrade the transmitted signals below the characterised performance.

RH.y) For ETSO-C153a CLASS RH, the IMA module shall ensure proper isolation of the interconnection function to prevent interference between signals (data, discrete I/O, power supply buses, etc.) that would affect data integrity, latency, and control.

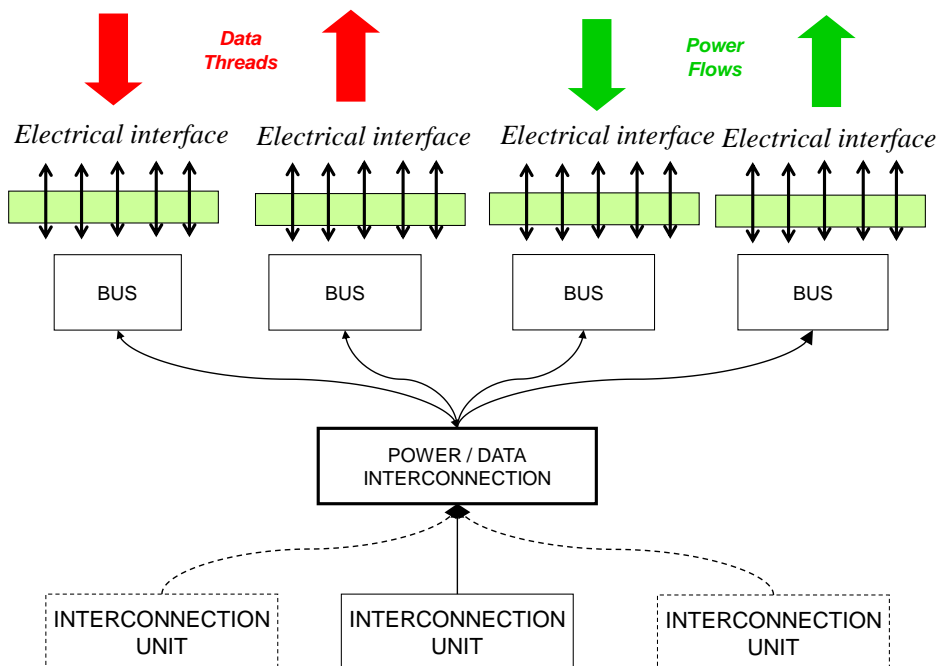

Figure 12: CLASS RH — the relationship between interconnection elements

2.3.2. Characterisation requirements for ETSO-C153a CLASS RH (F3) Interconnection

RH.z) The characterisation shall include attenuation profiles, signal integrity, cross-talk and tolerance rates. These shall be measured and guaranteed.

RH.aa) The performances of each of the types of buses provided in RH.u a) shall be characterised, quantified and guaranteed.

RH.bb) For at least the following failure modes, the failure rate shall be provided:

- a. a loss of the interconnection function; and
- b. erroneous behaviour of the interconnection function.

RH.cc) The characterisation shall address the safety aspects of sequencing, delay, corruption and impersonation.

RH.dd) The characterisation shall include the list of types of buses, their associated attributes, their configurability, and their sizing and performance.

2.4. Requirements for Temperature control (F4)

F4 is an optional sub-function of ETSO-C153a CLASS RH (F4): Temperature control

In this case, the IMA module provides the capability to control the temperature inside the rack for each mounted module.

This control may be realised by:

- distributing airflow between the aircraft environment (outside the rack) and the mounted hardware modules inside the IMA module (rack);
- enforcing airflow (convection) within the cooling generation unit;
- facilitating conduction between mounted hardware modules and the heat sinkers part of the Rack module.

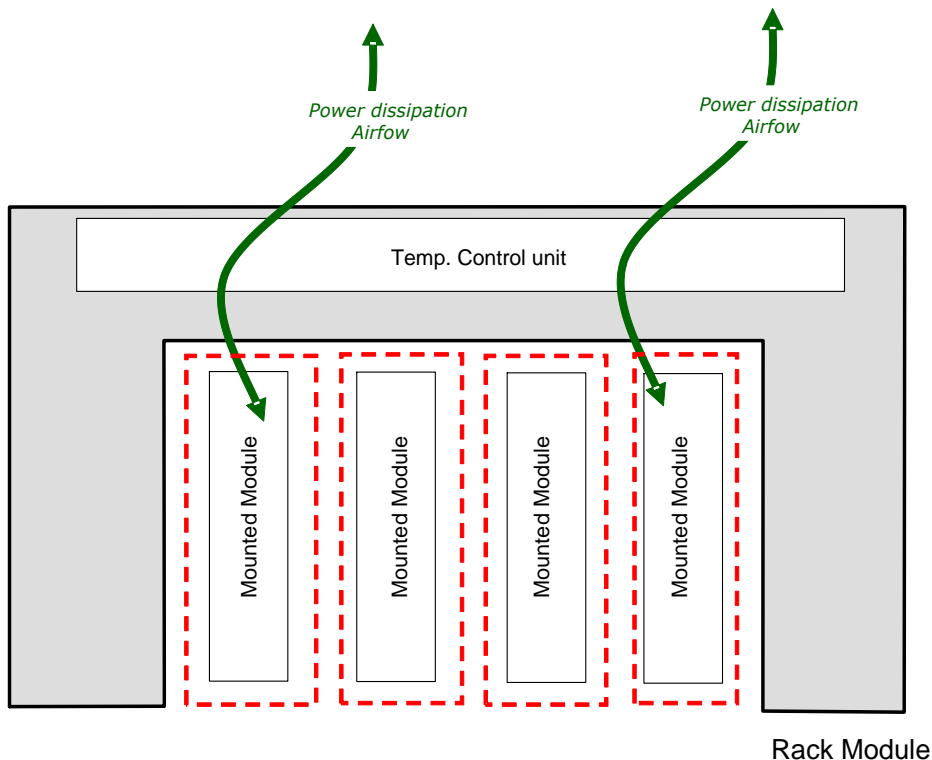

Figure 13: CLASS RH cooling function overview

2.4.1. Functional requirements for ETSO-C153a CLASS RH (F4): Temperature control

RH.ee) The IMA module shall provide regulated temperature control of the mounted hardware module. This control shall be ensured per slot in a determined temperature range.

RH.ff) The IMA module may provide an active means (temperature control unit) to control the temperature between the aircraft environment and the mounted hardware modules.

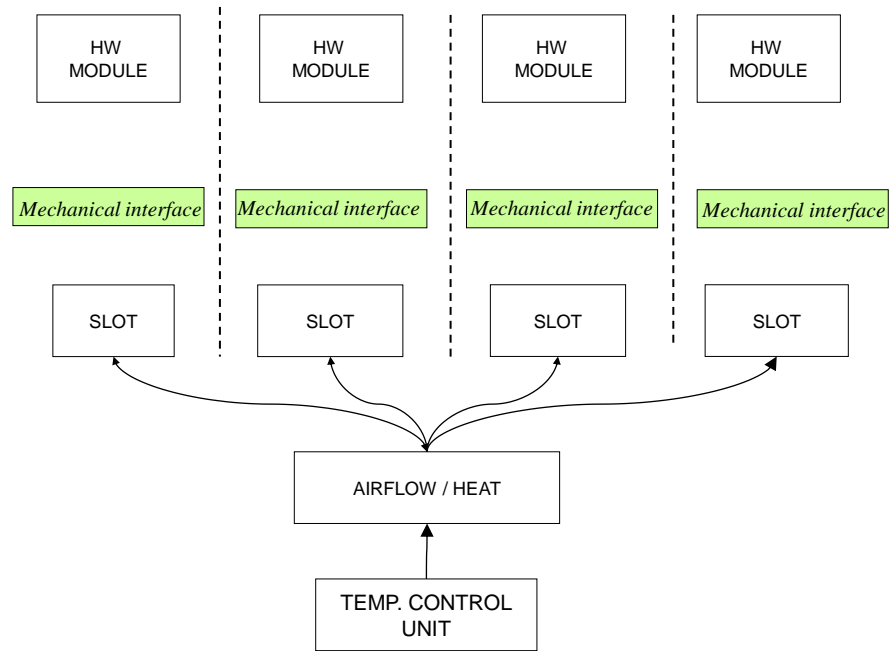

Figure 14: CLASS RH — the relationship between the cooling elements

2.4.2. Characterisation requirements for ETSO-C153a CLASS RH (F4)

RH.gg) The heat exchange performance of each slot provided shall be characterised, quantified and guaranteed in the installation manual.

RH.hh) For at least the following failure modes, the failure rate shall be provided:

- a. a loss of the active temperature control function; and
- b. erroneous behaviour of the active temperature control function.

RH.ii) Reserved

RH.jj) Reserved

3. Verification procedures

The following table gives the verification method for each MPS; nevertheless, an alternative method may be proposed to the certification authority:

Requirement identifier	Verification method	Test under normal conditions	Test under environmental conditions	Applicable ED-14/DO-160 sections
RH.a)	I+T	Y	Y ⁽²⁾	no ED-14 Section, see (2)
RH.b)	T	Y	Y	ED-14 Sections 4, 5, 7 and 8
RH.c)	I+T		Y ⁽²⁾	no ED-14 section, see (2)
RH.d)	I			

RH.e)	I/A			
RH.f)	I			
RH.g)	I			
RH.h)	I+A			
RH.i)	A			
RH.j)	I+T	Y		
RH.k)	I			
RH.l)	I			
RH.m)	T	Y	Y	Appropriate ED-14 sections addressing the shielding characteristics and, as a minimum, Sections 18, 19, 20 and 22
RH.n)				
RH.o)	I			
RH.p)	I			
RH.q)	I+A			
RH.r)	I			
RH.s)	T	Y	Y	Appropriate ED-14 sections addressing the shielding characteristics and, as a minimum, Sections 18, 19, 20 and 22
RH.t)	I			
RH.u)	T	Y	Y ⁽¹⁾	ED-14 Sections 4, 5, 6, 7, 8, and 16 to 22
RH.v)	A+T	Y	Y	ED-14 Sections 16 to 22
RH.w)	T	Y	Y ⁽¹⁾	ED-14 Sections 4, 5, 7 and 16 to 22
RH.x)	T	Y	Y	ED-14 Sections 4, 5 and 7
RH.y)	A			
RH.z)	T(A*)	Y		

RH.aa)	T(A*)	Y ⁽¹⁾	Y ⁽¹⁾	ED-14 Sections 4, 5 and 7
RH.bb)	A	Y		
RH.cc)	T(A*)	Y ⁽¹⁾		
RH.dd)	I			
RH.ee)	T	Y	Y	ED-14 Sections 4 and 5
RH.ff)	I+T	Y	Y	ED-14 Sections 4 and 5
RH.gg)	I+T	Y	Y	ED-14 Sections 4, 5, 6 and 7
RH.hh)	A			
RH.ii)				
RH.jj)				

Table 2: Verification Acceptance Criteria

(A*) means that verification by the Analysis method is possible for the item that cannot be tested.

Note (1): applicable for a functional subset → cf. **CO.gg)**.

Note (2): test to be completed after environmental testing.

[Amdt ETSO/10]

[Amdt ETSO/16]

Appendix 2.3 to ETSO-C153a – Integrated Modular Avionics (IMA) Platform and Module Minimum Performance Standard (MPS)

ED Decision 2020/011/R

CLASS PR: Processing

1. Purpose and scope

1.1. Introduction

This Appendix contains the Minimum Performance Standards (MPSs) for the CLASS PR Intended Function: Processing (PR).

These standards specify characteristics that should be useful to designers, manufacturers, installers and users of the IMA module.

1.2. Definitions

For ETSO-C153a CLASS PR, the IMA module provides shared resources in terms of processing between hosted applications, modules and/or components.

The following definitions are used:

- Processing Unit: a set of physical components (hardware and/or software) in charge of carrying out the instructions of a computer programme by performing the basic arithmetical, logical, and input/output operations of the Executable Object Code.
- Executable Object Code (EUROCAE ED-12C/RTCA DO-178C): a form of code that is directly usable by the processing unit of the target computer and is, therefore, a compiled, assembled, and linked binary image, loaded into the target computing hardware.
- Processing Element: a well-defined set of instructions which is a primary form of an Executable Object Code execution and for which a level of isolation would be guaranteed by the IMA module.

In the context of PR class, the ‘concurrent item’ defined in Appendix 2.1, paragraph 1 means ‘Processing Element’.

1.3. Intended Function

For ETSO-C153a CLASS PR, the intended function is to provide the capability to share the processing supplied by one or several processing unit(s).

The IMA module may include data storage and interfaces between hosted applications, modules and/or components; in this case, this class shall be combined with the DS and IF Classes.

The following figure provides an overview of the intended function of the above-mentioned IMA module and the associated definitions:

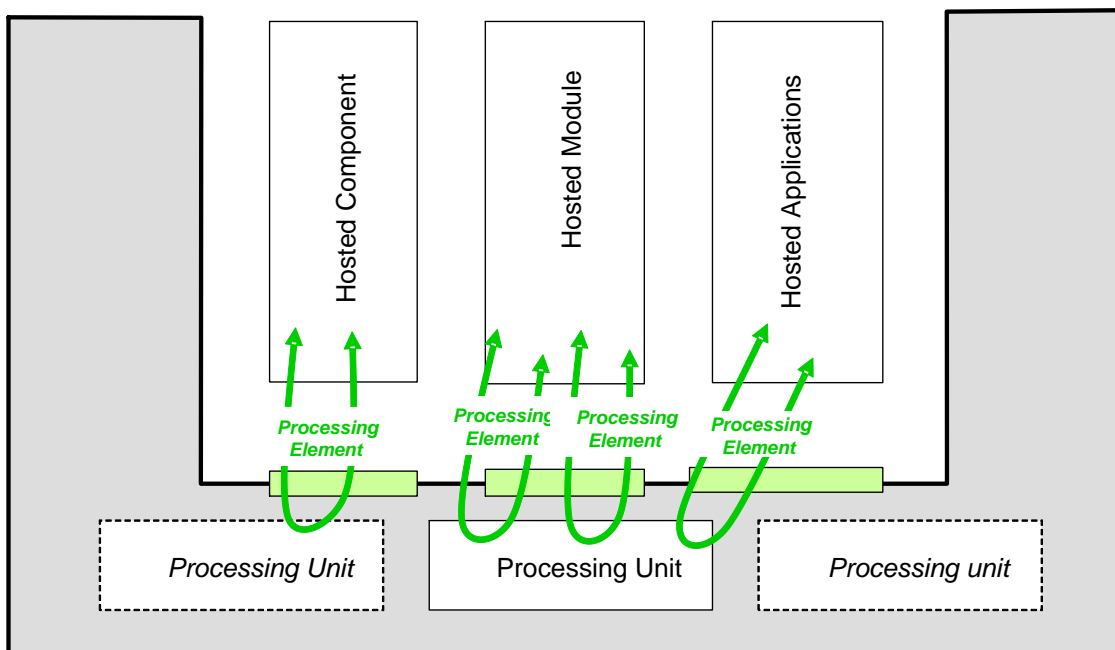

IMA Module

Figure 15: IMA module overview for ETSO-C153a CLASS PR

2. Requirements

2.1. Functional requirements for ETSO-C153a CLASS PR

- PR.a) The IMA module shall provide to hosted applications a Processing Resource which has the capacity to execute a set of instructions of a computer programme by performing the basic arithmetical, logical, and input/output operations of their Executable Object Code;
- PR.b) The IMA module shall be able to host applications and/or Executable Object Code(s) components.
- PR.c) The IMA module shall provide to hosted applications the capacity to share the Processing Resource thanks to Processing Elements managed through a logical interface, such as an Application Programme Interface (API).

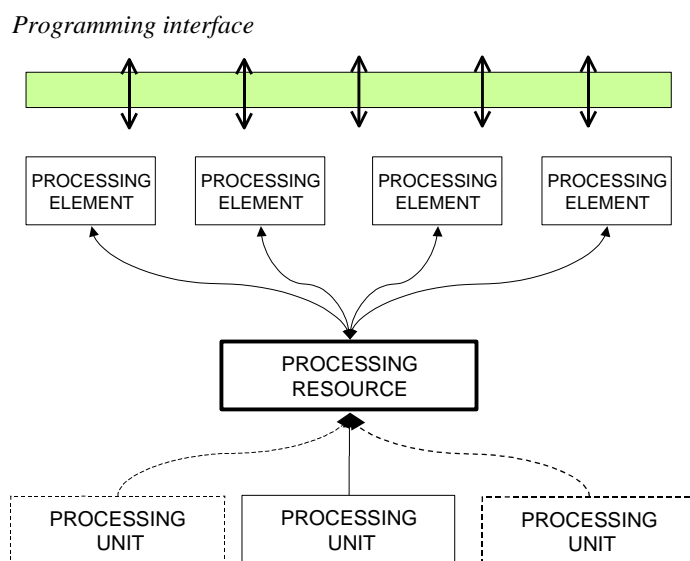

Figure 16: CLASS PR — the relationship between the processing elements

2.2. Characterisation requirements for ETSO-C153a CLASS PR

PR.d) All aspects of the processing performance of the shared Processing Unit of the IMA module shall be characterised, including, but not limited to, the following:

1. Processing Unit throughput (performance capacities and timings);
2. Performance of User Software/Software Interface (Core Software) Mechanism(s), Protocol(s), and Service(s);
3. Performance of User Hardware/Software Interface Mechanism(s), Protocol(s) and Service(s);
4. Performance of supported Processing Element Type (e.g. application, partition, process, thread, etc.);
5. Performance of Interrupt Mechanisms; and
6. Performance of Memory Management, including cache and Memory Management Unit (MMU).

Note: These performance requirements are additional to those applicable in Appendix 2.1 — COMMON.

3. Verification procedures

The following table gives the verification method for each MPS; nevertheless, an alternative method may be proposed to the certification authority:

Requirement identifier	Verification method	Test under normal conditions	Test under environmental conditions	Comment
PR.a)	T	Y	Y	
PR.b)	T	Y	Y	
PR.c)	T	Y	Y	
PR.d)	T (A*)	Y	Y ⁽¹⁾	

Table 3: Verification Acceptance Criteria

(A*) means that verification by the Analysis method is possible for the item that cannot be tested.

Note (1): applicable for a functional subset → cf. CO.gg).

[Amdt ETSO/10]

[Amdt ETSO/16]

Appendix 2.4 to ETSO-C153a – Integrated Modular Avionics (IMA) Module Minimum Performance Standard (MPS)

ED Decision 2020/011/R

CLASS GP: Graphical Processing

1. Purpose and scope

1.1. Introduction

This Appendix contains the Minimum Performance Standard (MPS) for the CLASS GP Intended Function: Graphical Processing.

These standards specify characteristics that should be useful to designers, manufacturers, installers and users of the IMA module.

1.2. Definitions

For ETSO-C153a CLASS GP, the IMA module provides shared resources in terms of graphical conversion and graphical laying out between hosted applications, modules and/or components based on commands coming from these hosted applications, modules and/or components.

The following definitions are used:

- Graphical Thread: a set of graphical (displayable) information for which a level of isolation would be guaranteed by the IMA module.
- Data Thread: a well-defined set of data which is a primary form of the drawing directives received as input by the IMA module from hosted applications, modules and/or components.
- Command Thread: a well-defined set of command directives received as input by the IMA module from hosted applications, modules and/or components in order to change the conversion and laying out settings.
- Graphical conversion: a transformation of a set of data information that is the primary form of drawing directives (data thread) into a set of displayable basic information.
- Laying out: an operation consisting of a combination of merging or/and splitting actions of displayable basic information in order to build the final Graphical Thread to be rendered.
- Conversion Unit: a set of physical components (hardware and/or software) in charge of graphical conversion.
- Laying out Unit: a set of physical components (hardware and/or software) in charge of laying out.

Note:

- both units can be merged in one unit; and
- the final rendering of the graphical thread(s) is out of the scope of this module (refer to CLASS DH).

In the context of GP class, the ‘concurrent item’ defined in Appendix 2.1, paragraph 1 means ‘Graphical and/or Command Thread’.

1.3. Intended Function

For ETSO-C153a CLASS GP, the intended function is to provide the capability to share graphical conversion and graphical laying out supplied by one or several graphical conversion and graphical laying out unit(s).

The function of the Graphical Processing Module is to receive commands from hosted applications, modules and/or components and optionally receive video from external analogue or digital sources to process them and to generate an image to display.

This intended function is Graphical Conversion and Laying out resource sharing composed of:

- information acquisition and control;
- information conversion and laying out; and
- information forwarding & control.

The following figure provides an overview of the above-mentioned IMA module intended function and associated definitions:

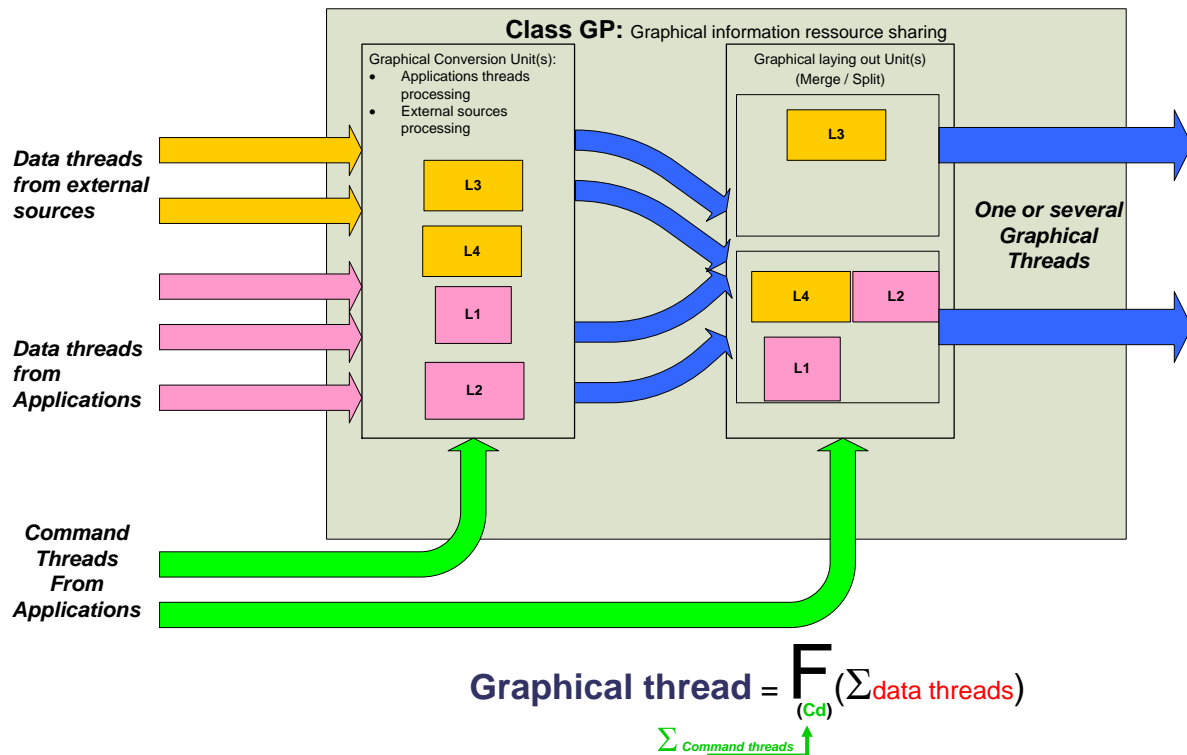

Figure 17: IMA module overview for ETSO-C153a CLASS GP

2. Requirements

2.1. Functional requirements for ETSO-C153a CLASS GP

GP.a) The IMA module shall provide, to hosted applications, a Graphical Conversion Resource which has the capability to transform a set of drawing directives into a set of displayable basic information.

GP.b) The IMA module shall provide, to hosted applications, a Graphical Laying out Resource which has the capability to merge or/and split displayable basic information to build the final Graphical Thread(s) to be rendered.

GP.c) The IMA module shall provide to hosted applications, modules and/or components, the capability to change the graphical conversion and laying out settings through command threads.

GP.d) The IMA Module shall provide to hosted applications, modules and/or components, the capability to share a Graphical Conversion Resource and a Graphical Laying out Resource based on command threads managed through (a) logical and/or physical interface(s).

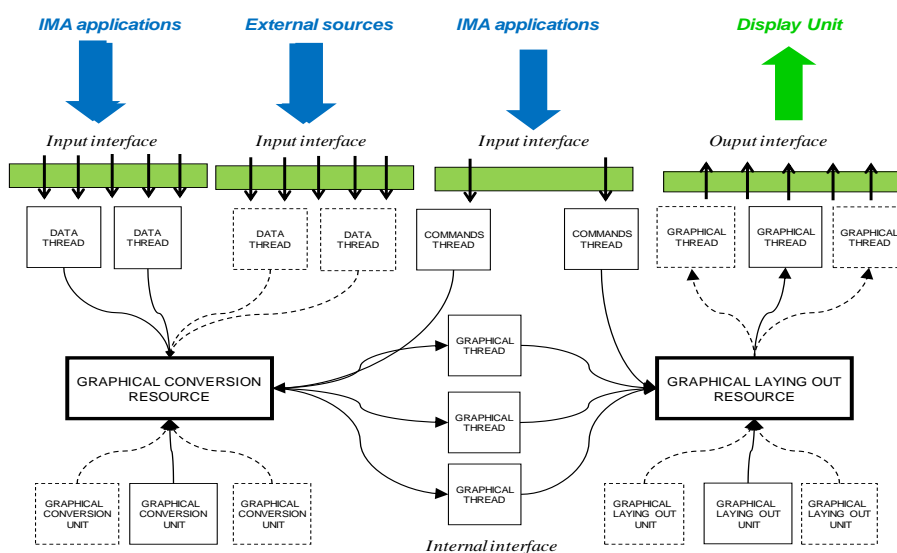

Figure 18: CLASS GP — the relationship between the Graphical Processing (GP) elements

2.2. Characterisation requirements for ETSO-C153a CLASS

GP.e) The following aspects of the performance of the Graphical Unit(s) performance of the IMA module shall be quantified and guaranteed:

1. Graphical Unit(s) throughput (performance capacities and timings: response time, graphical update);
2. Performances of User Software/Software Interface (Core Software) Mechanism(s), Protocol(s), and Service(s);
3. Performance of User Hardware/Software Interface Mechanism(s), Protocol(s) and Service(s);
4. Establishment of Worst-Case Graphical Elaboration Time;
5. Performance of Interrupt Mechanisms;
6. Performance of supported Data Thread types;
7. Performance of supported Graphical Thread types; and
8. Performance of supported Command Thread types.

Note: These performance requirements are additional to those applicable in Appendix 2.1 — COMMON.

GP.f) In addition to the Common CO.w), particular emphasis shall be given to precluding or mitigating failures which could result in hazardously misleading information.

Undetected loss of information or frozen information could contribute to hazariously misleading information.

Note: This is applicable to all the GP module functionality, including the implementation of image windowing, superimposition etc.

3. Verification procedures

The following table gives the verification method for each MPS; nevertheless, an alternative method may be proposed to the certification authority:

Requirement identifier	Verification method	Test under normal conditions	Test under environmental conditions	Comment
GP.a)	T	Y	Y	
GP.b)	T	Y	Y	
GP.c)	T	Y	Y	
GP.d)	T	Y	Y	
GP.e)	T(A*)	Y	Y ⁽¹⁾	
GP.f)	I			

Table 4: Verification Acceptance Criteria

(A*) means that verification by the Analysis method is possible for the item that cannot be tested.

Note (1): applicable for a functional subset → cf. CO.gg).

[Amdt ETSO/10]
[Amdt ETSO/16]

Appendix 2.5 to ETSO-C153a – Integrated Modular Avionics (IMA) Platform and Module Minimum Performance Standard (MPS)

ED Decision 2020/011/R

CLASS DS: Data Storage (DS)

1. Purpose and scope

1.1. Introduction

This Appendix contains the Minimum Performance Standard (MPS) for the CLASS DS Intended Function: Data Storage.

These standards specify characteristics that should be useful to designers, manufacturers, installers and users of the IMA module.

1.2. Definitions

For ETSO-C153a CLASS DS, the IMA module provides shared resources in terms of data storage between hosted applications, modules and/or components.

Data Storage refers to the storage of data in a continuing and machine-readable mode. A Data Storage module that records data may access both the separate portable (removable) recording component and/or a permanent component to store and retrieve data.

The following definitions are used:

- Storage Unit: a set of physical components (hardware and/or software) in charge of supplying and managing recorded data resources (e.g. memory components and the associated interfaces, etc.)
- Data Storage Element: a completely defined set of data storage which is a primary form of recorded data and for which a level of isolation would be guaranteed by the IMA module.

In the context of DS class, the ‘concurrent item’ defined in Appendix 2.1, paragraph 1 means ‘Data Storage Element’.

1.3. Intended Function

For ETSO-C153a CLASS DS, the intended function is to provide the capability to share recorded data or data storage space supplied by one or several storage unit(s).

2. Requirements

2.1. Functional requirements for ETSO-C153a CLASS DS

DS.a) The IMA module shall provide to hosted applications, modules and/or components, a Data Storage Resource which has the capacity to record or to retrieve a set of data on/from a storage unit by performing data-retaining operations.

DS.b) The IMA module shall provide to hosted applications, modules and/or components, the capacity to use shared recorded data resources thanks to data storage elements accessible through (a) logical and/or physical interface(s).

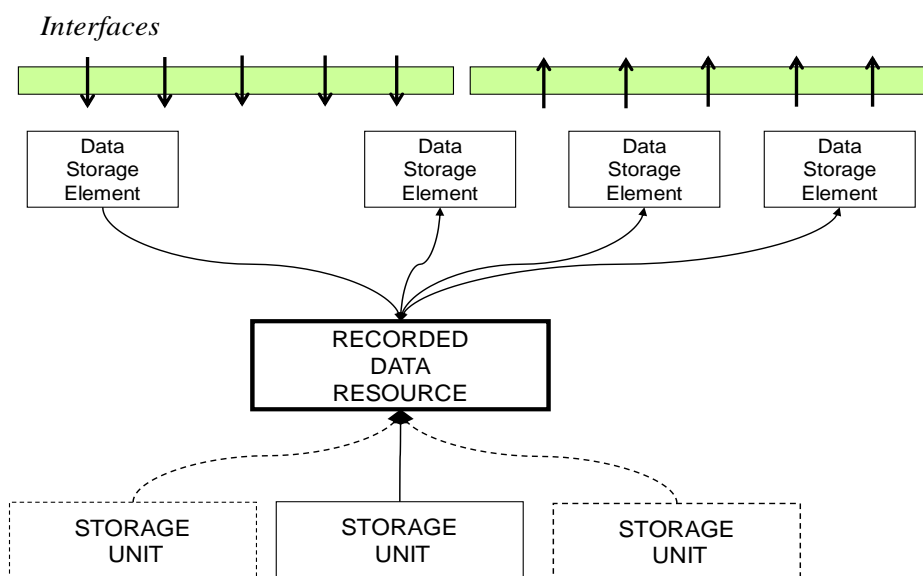

Figure 19: CLASS DS — the relationship between the data storage elements

2.2. Characterisation requirements

DS.c) All aspects of the Data Storage performance of the shared Storage Unit of the IMA module shall be characterised, including but not limited to the following:

1. performances of Memory Management functionality, including the cache and Memory Management Unit (e.g. storage capacity, cache performance, etc.);
2. performance of (a) User Interface Mechanism(s), Protocol(s) and Service(s) (e.g. access timings and throughputs, etc.); and
3. performance of a supported Data Storage Element Type (e.g. namespace, address scheme, arbitrary principles for multiple access, throughputs, timings, data space, etc.).

Note: These performance requirements are additional to those applicable in Appendix 2.1 — COMMON.

3. Verification procedures

The following table gives the verification method for each MPS; nevertheless, an alternative method may be proposed to the certification authority:

Requirement identifier	Verification method	Test under normal conditions	Test under environmental conditions	Comment
DS.a)	T	Y	Y	
DS.b)	T	Y	Y	
DS.c)	T(A*)	Y	Y ⁽¹⁾	

Table 5: Verification Acceptance Criteria

(A*) means that verification by the Analysis method is possible for the item that cannot be tested.

Note (1): applicable for a functional subset → cf. CO.gg.

[Amdt ETSO/10]
[Amdt ETSO/16]

Appendix 2.6 to ETSO-C153a – Integrated Modular Avionics (IMA) Module Minimum Performance Standard (MPS)

ED Decision 2020/011/R

CLASS IF: Interface

1. Purpose and scope

1.1. Introduction

This Appendix contains the Minimum Performance Standards (MPS) for the CLASS IF Intended Function: Interface.

These standards specify characteristics that should be useful to designers, manufacturers, installers and users of the IMA module.

1.2. Definitions

For ETSO-C153a CLASS IF, the IMA module provides shared resources in terms of interfaces between hosted applications, modules and/or components.

The following definitions are used:

- Interface Unit: a set of hardware and/or software components in charge of supplying and managing a shared information resource.
- Data Thread: a well-defined set of data which is a primary form of information and for which a level of isolation would be guaranteed by the IMA module.

Each data thread handled by the Interface, if so wished by the applicant, may be bidirectional or symmetrical between interconnected components, modules, or hosted applications.

In the context of IF class, the ‘concurrent item’ defined in Appendix 2.1, paragraph 1 means ‘Data Thread’.

1.3. Intended Function

For ETSO-C153a CLASS IF, the intended function is to provide the capability to share information supplied by one or several interfaces units.

This intended function is Information Sharing composed of:

- information acquisition and control;
- information conversion and; and
- information forwarding and control.

The information-forwarding and control function is the means that allows sharing information between components, modules and/or hosted applications.

The following figure provides an overview of the above-mentioned intended function and the associated definitions:

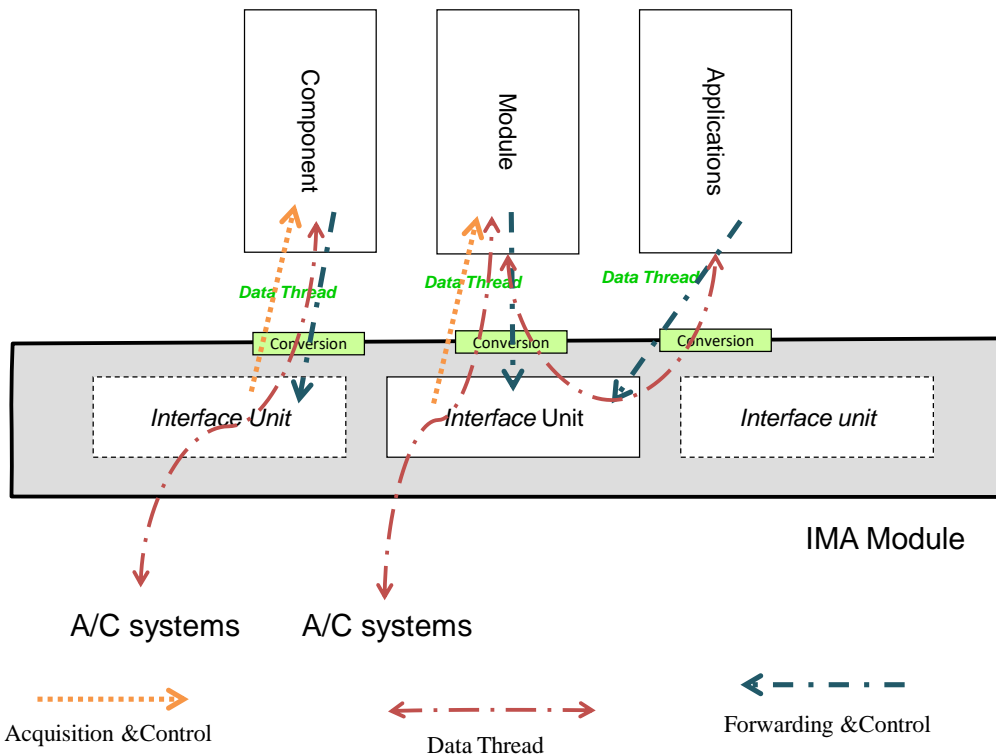

Figure 20: IMA module overview for ETSO-C153a CLASS IF

2. Requirements

For ETSO-C153a CLASS IF, the IMA module provides shared resources for the communication needs of hosted applications, modules and/or components.

2.1. Functional requirements for ETSO-C153a CLASS IF:

- IF.a) The IMA module shall provide to hosted applications, modules and/or components, an Information Resource which has the capacity to acquire from or to forward to an interface unit a set of data by performing information coding and decoding operations.
- IF.b) The IMA module shall provide to hosted applications, modules and/or components, the capacity to use shared Information Resource thanks to Data Threads handled through logical and/or physical interface(s).

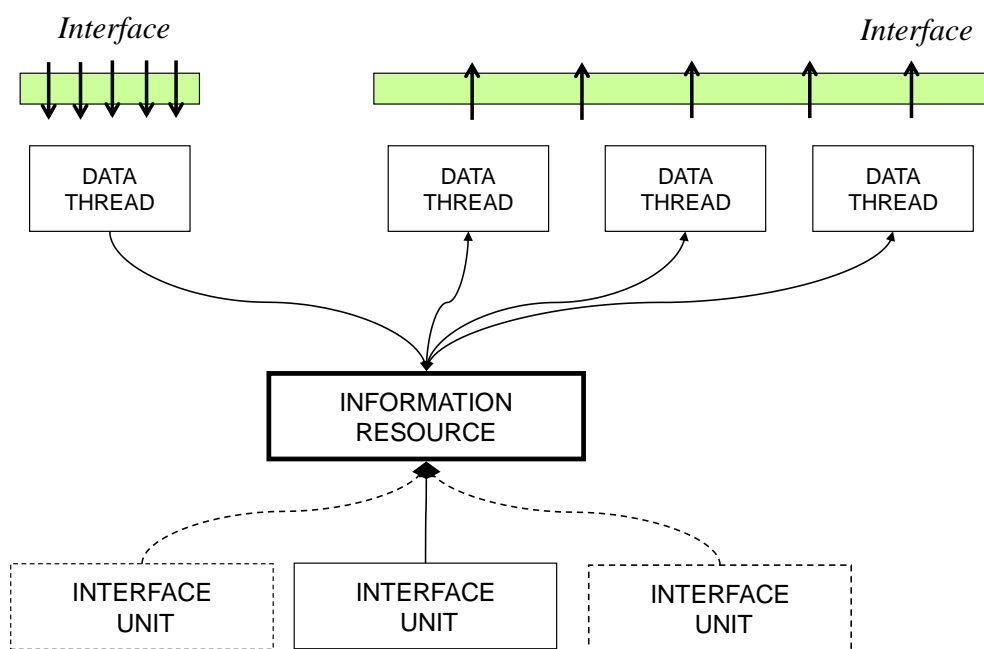

Figure 21: The relationship between CLASS IF interface (IF) elements

1.1. Characterisation requirements for ETSO-C153a CLASS IF:

IF.c) All performances of the shared Interface Unit of the IMA module shall be characterised, including but not limited to the following:

1. performance of each Interface, including its throughput, acquisition speed, forwarding speed, latency, jitter, coding rate and decoding rate;
2. performance of (a) User Interface Mechanism(s), Protocol(s) and Service(s) (e.g. socket timing, communication port timing, technological time delay, etc.); and
3. performance of supported Data Thread Type (e.g. virtual link, channel, pipe-and-filter, physical connection pin, etc.).

Note: These performance requirements are additional to those applicable in Appendix 2.1 — COMMON.

IF.d) In addition to the Common Requirement CO.w), the characterisation shall address the safety aspects of frozen data.

2. Verification procedures

The following table gives the verification method for each MPS; nevertheless, an alternative method may be proposed to the certification authority:

Requirement identifier	Verification method	Test under normal conditions	Test under environmental conditions	Comment
IF.a)	T	Y	Y	
IF.b)	T	Y	Y	
IF.c)	T(A*)	Y	Y ⁽¹⁾	
IF.d)	T or A*			

Table 6: Verification Acceptance Criteria

(A*) means that verification by the Analysis method is possible for the item that cannot be tested.

Note (1): applicable for a functional subset → cf. **CO.gg.**

[Amdt ETSO/10]

[Amdt ETSO/16]

Appendix 2.7 to ETSO-C153a – Integrated Modular Avionics (IMA) Platform and Module Minimum Performance Standard (MPS)

ED Decision 2020/011/R

CLASS PS: Power Supply (PS)

1. Purpose and scope

1.1. Introduction

This Appendix contains the Minimum Performance Standard (MPS) for the CLASS PS Intended Function: Power Supply (PS).

These standards specify module characteristics that should be useful to designers, manufacturers, installers and users of the module.

1.2. Definitions

For ETSO-C153a CLASS PS, the IMA module is a module, mounted into a rack or the rack itself, able to supply power received from the aircraft electrical network to one or more hardware modules mounted in the same rack.

The following definitions are used:

- Power supply unit: a set of physical components (hardware and or software) in charge of managing a power supply (or a part of the power supply) resource.
- Power supply resource: obtained electrical energy from the aircraft electrical network to be distributed to electrical loads which are modules mounted into the rack.
- Power rail: a part of supplied electrical energy for which a level of isolation is guaranteed by the IMA module.
- Mounted: it refers to another hardware module installed and fixed inside the IMA Rack Module after a manual operation.
- Slot: a physical space inside the Rack Module allocated to one hardware module.
- Hold-up Capacity: The capacity of the power supply to continue supplying output current after the input voltage drops below the minimum level. This is usually expressed as the time from the input voltage drop to the reset generated by the power supply to the processor.
- Output Current Capacity: the continuously operating maximum current supplied for each output voltage.
- Power Monitors & Status Outputs: a separate circuitry which checks the output voltage levels and current loading of the power supply. This circuitry will generate one or more binary signals that may be connected to the processor to alert it to the 'out of spec' condition. These binary signals may also force the power supply to shutdown to prevent damage to power supply components.
- Power Resets: a binary signal output from the power supply that is asserted when the output voltages are outside acceptable tolerances.
- Regulation: the percentage of variation of the output voltages when subjected to changes in load, changes in temperature, and changes in all input voltage transients and deviations.

- Transient Immunity: the ability of the power supply to continue operating normally during variations in the input voltage. This is usually expressed as the time duration and the voltage level of the transient.
- Voltage Outputs and Tolerances: the voltage levels and tolerances of the outputs produced by the power supply.

In the context of PS class, the ‘concurrent item’ defined in Appendix 2.1, paragraph 1 means ‘Power Rail’.

1.3. Intended Function

For ETSO-C153a CLASS PS, the intended function is to provide the capability to share the Power Supply resource supplied by one or more Power Supply unit(s).

The following figure provides an overview of the above-mentioned intended function and definitions:

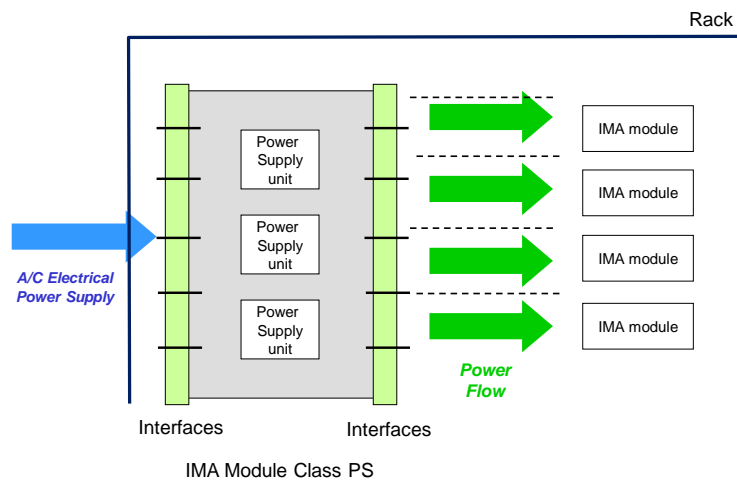

Figure 22: IMA module overview of ETSO-C153a CLASS PS

2. Requirements

2.1. Functional requirements for ETSO-C153a CLASS PS

- PS.a) The IMA module shall provide to hardware modules mounted in the same rack Power Supply Resource which has the capacity to deliver a quantity of electrical energy from power supply unit(s) to the hardware modules while performing the regulation operations.
- PS.b) The IMA module shall provide to hardware modules mounted into the same rack the capacity to share the power supply resource thanks to power rails accessible through physical interface(s).

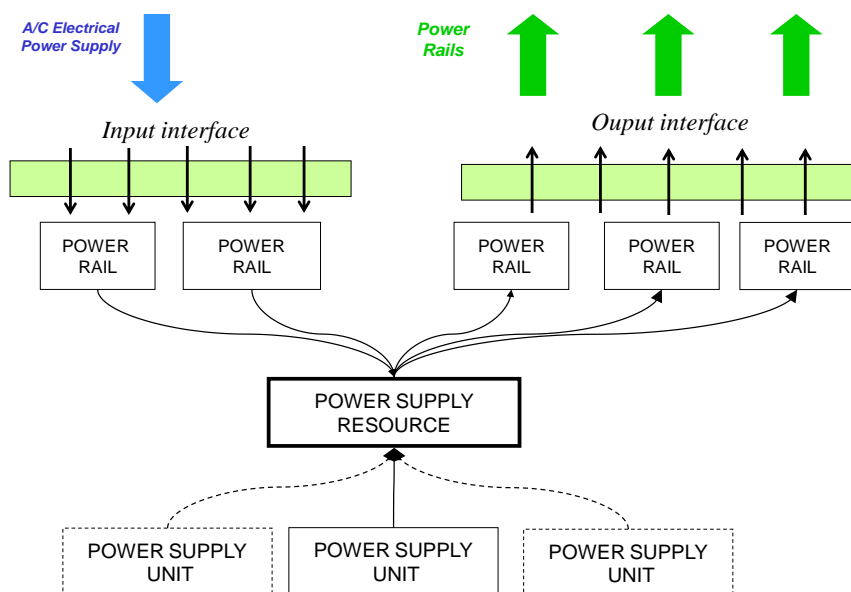

Figure 23: CLASS PS (PS) — the relationship between the elements

2.2. Characterisation requirements

PS.c) All aspects of the performance of the Power Supply of the shared Power Supply Unit of the IMA module shall be characterised, including but not limited to the following:

1. The needed input power budget characteristics (e.g. as a function of temperature and load)
2. The performance of Output Currents and Tolerances;
3. The performance of Hold-up Capacity;
4. The performance of Power Monitors and Status Outputs;
5. The performance of Power Resets;
6. The performance of Power Regulation;
7. The performance of Transient Immunity;
8. The performance of Voltage Outputs and Tolerances;
9. The performance of User Interface Mechanism(s), Protocol(s) and Service(s);
10. The performance of a supported Power Rail Type;
11. The Input and Output impedance; and
12. The capacitive load.

Note: These performance requirements are additional to those applicable to and dictated by the design of the IMA module itself (according to the 'COMMON' requirement of Appendix 2.1).

PS.d) In addition to the Common Requirement CO.w), the characterisation shall address the safety aspects of events such as a too low voltage or current, and a too high voltage or current. The transient, as well as permanent effects, shall also be characterised, if relevant.

PS.e) The characterisation shall provide any data needed to evaluate the power profile characteristics (e.g. Maximum Value, InRush Current) of managed power rails, and the IMA module power on/power off behaviour characteristics.

3. Verification procedures

The following table gives the verification method for each MPS; nevertheless, an alternative method may be proposed to the certification authority:

Requirement identifier	Verification method	Test under normal conditions	Test under environmental conditions	Comment
PS.a)	T	Y	Y	
PS.b)	T	Y	Y	
PS.c)	T(A*)	Y	Y ⁽¹⁾	
PS.d)	T(A*)	Y		
PS.e)	A			

Table 7: Verification Acceptance Criteria

(A*) means that verification by the Analysis method is possible for the item that cannot be tested.

Note (1): applicable for a functional subset → cf. **CO.gg**.

[Amdt ETSO/10]

[Amdt ETSO/16]

Appendix 2.8 to ETSO-C153a – Integrated Modular Avionics (IMA) Platform and Module Minimum Performance Standard (MPS)

ED Decision 2020/011/R

CLASS DH: Display Head

1. Purpose and scope

1.1. Introduction

This Appendix contains the Minimum Performance Standards (MPS) for the CLASS DH Intended Function: Display Head.

These standards specify characteristics that should be useful to designers, manufacturers, installers and users of the module.

1.2. Definitions

For ETSO-C153a CLASS DH, the IMA module provides shared resources in terms of a display area between hosted applications, components and/or modules.

The following definitions are used:

- Display Unit: a set of physical components (hardware and/or software) in charge of managing a display area (or a part thereof).
- Display Area: a surface where some visual information can be depicted by one or several Display Unit(s) based on received Graphical Threads.
- Graphical Thread: a set of graphical information received as input by the Display Head from one or more IMA application(s), component(s) and/or module(s).
- Display Thread: a set of depiction information for which a level of isolation on the Display Area is guaranteed by the Display Head.

In the context of DH class, the 'concurrent item' defined in Appendix 2.1, paragraph 1 means 'Display Thread'.

1.3. Intended Function

For ETSO-C153a CLASS DH, the intended function is to provide the capability to share one display area supplied by one or several display unit(s).

The intended function of such an IMA module is to offer the capability to depict graphical information received from (an) IMA application(s), component(s) and/or module(s) on one Display Area.

The following figure provides an overview of the above-mentioned intended function and the associated interfaces:

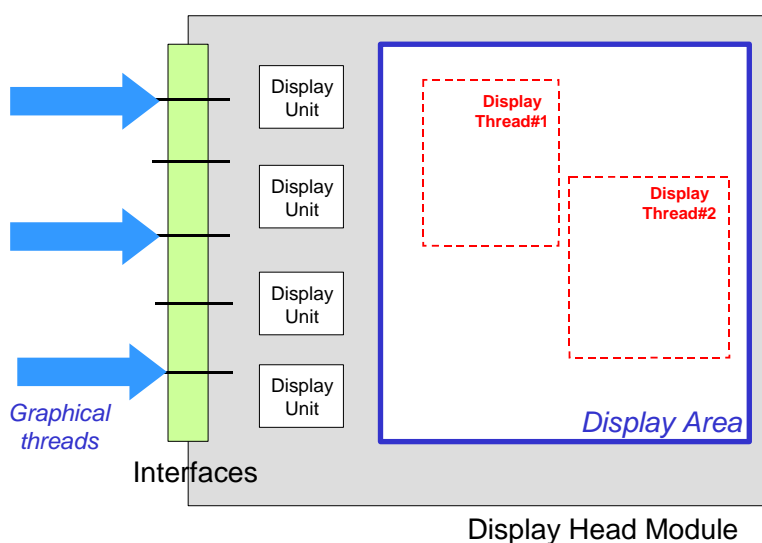

Figure 24: IMA module overview of ETSO-C153a CLASS DH

2. Requirements

2.1. Functional requirements for ETSO-C153a CLASS DH

DH.a) The IMA module shall provide to hosted applications, modules and/or components, a Display Area Resource which has the capability to render visual graphical information.

DH.b) The IMA module shall be fully or partially compliant with the MPS as from the applicable release of ETSO-C113.

Note 1: these performance requirements are additional to those applicable in Appendix 2.1 — COMMON.

Note 2: for Display Head modules without a Graphics generation function, compliance demonstration to some ETSO-C113 requirements might not be possible. In such cases, the applicant shall submit in the compliance data package the list of requirements that need further demonstration with regard to the C113 requirements providing a relevant justification.

DH.c) The IMA module shall provide to hosted applications, modules and/or components the capability to share a Display Area resource managed through a logical or physical interface.

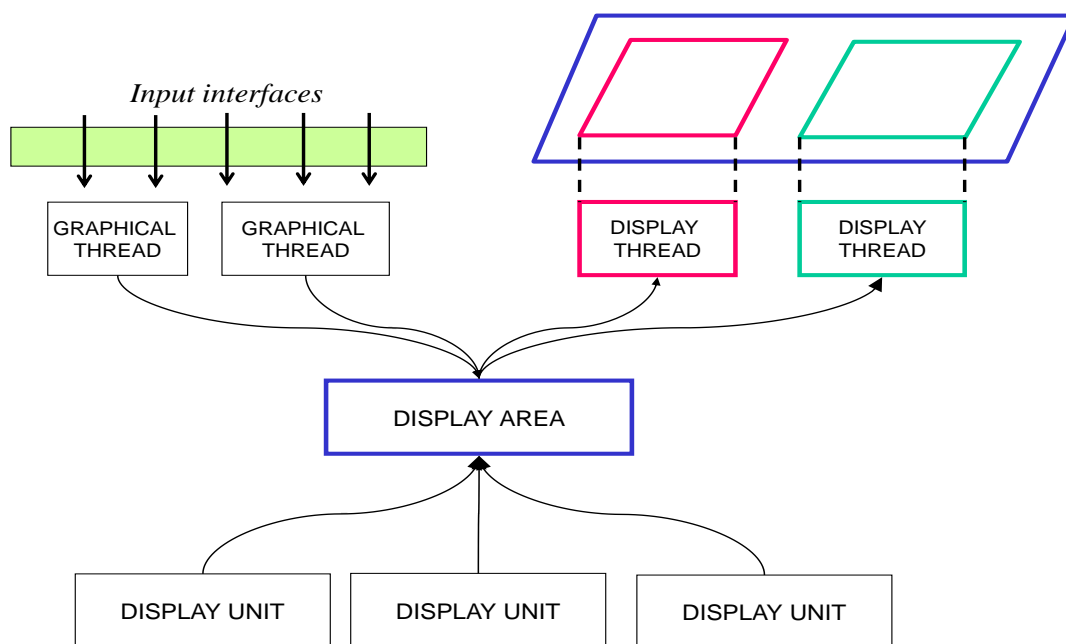

Figure 25: The relationship between CLASS DH Display Head elements

2.2. Characterisation requirements for ETSO-C153a CLASS DH

DH.d) In addition to the Common Requirement CO.w), the characterisation shall address the safety aspects of delay and/or frozen information.

DH.e) In addition to Common Requirement CO.s), the characterisation shall include any data needed to evaluate the Worst-Case Display Elaboration Time of managed threads, and the characteristics required by the applicable release of SAE AS8034 (as per the applicable revision of ETSO-C113).

DH.f) The additional activities to be performed by the user related to the applicable release of ETSO-C113 for complete compliance demonstration shall be included in the characterisation for gap identification.

3. Verification procedures

The following table gives a verification method for each MPS; nevertheless, an alternative method may be proposed to the certification authority:

Requirement identifier	Verification method	Test under normal conditions	Test under environmental conditions	Comment
DH.a)	T	Y	Y	
DH.b)	(2)	(2)	(2)	
DH.c)	T	Y	Y	
DH.d)	T/A*	Y		
DH.e)	A			
DH.f)	A			

Table 8: Verification Acceptance Criteria

(A*) means that verification by the Analysis method is possible for the item that cannot be tested.

Note (1): for the functional subset, see **CO.gg**.

Note (2): an applicable revision of ETSO-C113 defining the verification requirements of a display function.

[Amdt ETSO/10]

[Amdt ETSO/16]

Appendix 3 to ETSO-C153a – Integrated Modular Avionics (IMA) Module Data Requirements

ED Decision 2020/011/R

For an IMA module authorisation, as mentioned in paragraph 2.2 of the ETSO-C153a main body document, additional technical data shall be available or submitted. This data will be documented into a set of documents for the ETSO authorisation (qualification plans, compliance evidences, etc.) and for the IMA module users such as Application developers, Integrators or type certificate applicants (User Guide, Usage domain, etc.):

- Chapter 1 — IMA module ED-124 documentation;
- Chapter 2 — Specific User Guide and Installation Manual contents;
- Chapter 3 — Core software;
- Chapter 4 — Health management and reporting;
- Chapter 5 — Usage domain;
- Chapter 6 — Configuration;
- Chapter 7 — Tools; and
- Chapter 8 — Compatibility & mixability information.

Chapter 1 — IMA module ED-124 documentation

The IMA system approval can be made incremental by introducing some intermediate acceptance steps. An ETSO-C153a authorisation is the first intermediate step dedicated to authorising IMA platforms and/or IMA modules (independently of any specific aircraft installation).

EUROCAE ED-124/RTCA DO-297 contains guidance for Integrated Modular Avionics (IMA) developers, application developers, integrators, certification applicants, and those involved in the approval and continued airworthiness of IMA systems in civil certification projects.

As mentioned in paragraph 3.2.2.1 of the ETSO-C153a main body document, to prepare the integration of the ETSO-C153a IMA module, the development objectives are defined in the EUROCAE ED-124 guidance related to Task 1 (Table A-1 objectives).

For an ETSO-C153a approval, the following data are available (A) or submitted (S) to the competent authority:

EUROCAE ED-124 Life Cycle Data	EUROCAE ED-124 Life Cycle Section	Available (A)/Submitted (S)
Module Acceptance Plan	4.2.3	S
Module Requirements Specifications	4.2.4	A
Traceability Data	4.2.5	A
Module Design Data	4.2.4	A
Module Failure Analyses and Safety Analyses	4.2.12b	S
Module Tool Qualification Data	4.2.12c	S
Partitioning Analysis Data(1)	4.2.4i	S
V&V data (Validation and verification)	4.2.5	A
Module Acceptance Data Sheet	4.2.10	S

EUROCAE ED-124 Life Cycle Data	EUROCAE ED-124 Life Cycle Section	Available (A)/Submitted (S)
Interface Specifications	4.2.4f	A
Module User Guide	4.2.12e	S(2)
Module Quality Assurance (QA) Records	4.2.6	A
Module Configuration Management (CM) Records	4.2.8	A
Module Acceptance Accomplishment Summary	4.2.9	S
Module Acceptance Configuration Index	4.2.7	S
Module Open Problem Reports	4.2.11	S

Note (1): this Partitioning Analysis shall include the verification results obtained for demonstration of compliance of CO.e), CO.f), CO.g), and CO.h).

Note (2): only for User Guide content used for ETSO compliance demonstration.

Chapter 2 — Specific User Guide and Installation Manual contents

As per ED-124, the IMA module User guide shall be provided by the IMA module manufacturer to both the module users and the Airworthiness Authority.

This User Guide includes all the information for users, integrators, and certification applicants to successfully interface with or integrate the module, such as:

- guaranteed behaviour and characteristics as per CO.k);
- interfaces (incl. physical mapping of interfaces);
- limitations and Open Problem Reports (OPRs)(1) (including tools);
- the Worst-Case Execution Time (WCET) analysis elements;
- the applicable Failure Mode Effect Analysis/Failure Mode Effect Summary (extracts) necessary for higher level safety analysis;
- the Core Software (see Appendix 3, Chapter 3);
- Fault Management and Health Monitoring (see Appendix 3, Chapter 4);
- the Usage Domain (see Appendix 3, Chapter 5) ;
- configuration aspects (see Appendix 3, Chapter6);
- tools aspects (see Appendix 3, Chapter 7);
- compatibility and mixability information (see Appendix 3, Chapter 8);
- remaining activities to be conducted by the module user to complete the IMA module qualification (environment);
- requirements recommendations for applications (e.g. data for the qualification of the application, service available for applications, etc.); and
- requirements recommendations for System Integration.

- (1) An explicit description of the root cause and effects of an IMA module OPR is necessary to support the IMA module user and aircraft manufacturer in their assessment of the effects of the OPR on the aircraft function.

The Installation Manual includes all the data necessary for the proper installation and use of the IMA module (including marking aspects).

Each item of the characterisation and functional requirements is addressed in the User Guide (or possibly in the Installation Manual, if appropriate).

The User Guide defines the Usage Domain for which the module acceptance data is valid.

The information includes recommendations and may also include examples of the correct use of the module. In addition, the guide highlights any warnings or limitations to integrate or to interface with the module to prevent potential incorrect or unintended use.

The User Guide may be completed by the IMA module manufacturer with:

- information on Single Event Upset (SEU) effects;
- a Validation and Integration Kit for application developers and system integrators;
- Development and In-Service support; and
- some training.

The Installation Manual includes information as required in the MPS Appendix or referenced subsequent applicable chapter of the User Guide. In this case, the User Guide chapter will be submitted to the Airworthiness Authority (see Note (*) above).

The User Guide may be included in the Installation Manual of the IMA module (e.g. Annexes) or a separated document referenced by the Installation Manual.

Chapter 3 — Core Software

As defined in Appendix 1 above, the IMA module may be an association of Hardware and Core Software.

Core Software consists of the operating system and the support software that manage resources to provide an environment in which the intended function is performed. Core software is typically comprised of one or more component(s). Core Software may be resident or a Field-Loadable Software part.

If the IMA module contains Core Software, the Core Software characteristics required by CO.r) of Appendix 2 are documented in the IMA module User Guide.

Chapter 4 — Health management and reporting

The data requirements related to health management and reporting are listed in CO.x).

Chapter 5 — IMA module usage domain

An ETSO-C153a authorisation relies on the concept of a Usage Domain (as per Chapter 2 — Definitions of Appendix 1).

The usage domain is defined at the IMA module level and used at the Application level and the IMA system level.

The definition of the usage domain includes consideration of the module functionality, performance and safety requirements, as well as of the required environmental performance of the module.

The IMA module manufactured to comply with this ETSO may be used to support other ETSOs or systems approved under CS-23, CS-25, CS-27, CS-29, CS-E or CS-P. These ETSO authorisations, IMA system approvals and aircraft level approvals, are not covered by this ETSO but will rely on the fact that compliance with the Usage Domain as documented in the User Guide, is correctly implemented.

Chapter 6 — Configuration

The IMA module may need to be configured before installation in the IMA system (EUROCAEED-124, Tasks 2, 3 and 4).

The data requirements related to configurability are listed in CO.y) of Appendix 2.

Chapter 7 — Tools

Some tools may need to be used during the installation of the IMA module in the IMA system (EUROCAE ED-124 Tasks 2, 3 and 4). These tools may be used by:

- application developers;
- (an) integrator(s); and
- type certificate (TC) or supplemental type certificate (STC) applicants.

These tools may address:

- software development (hosted applications);
- configuration development;
- network architecture and configuration;
- debug, data loading; and
- WCET analysis and measures.

In that case, the User Guide references each tool in the data listed in Appendix 2 CO.z).

If qualification credit is expected from these tools (such as configuration tools), the qualification process and data requirements are defined in paragraph 2.2 of CS-ETSO Subpart A. Software standards as well as the Airborne Electronic Hardware Qualification data of paragraph 2.3 are considered to be data to be submitted to EASA in the frame of an ETSO-C153a authorisation.

Chapter 8 — Compatibility and mixability information

The IMA module manufacturer provides compatibility and mixability information between hardware, software, tools and the usage domain in the User Guide, as required per CO.aa) of Appendix 2.

[Amdt ETSO/10]

[Amdt ETSO/16]

Appendix 4 to ETSO-C153a – Integrated Modular Avionics (IMA) Module Environmental Qualification Requirements

ED Decision 2020/011/R

Section 2.3 of CS-ETSO Subpart A requires environmental testing to be performed according to the appropriate release of EUROCAE ED-14/RTCA DO-160.

For ETSO-C153a, some particularities have to be addressed:

- the representativeness of the Test Software;
- the Applicable Test Procedures; and
- the parameters to be monitored during the Environmental Qualification Test.

Chapter 1 — The representativeness of the Test Software

If the IMA module is qualified without the functional software installed and operating, engineering analysis from the manufacturer must determine that the Test Software (not the target functional software) is representative of the usage domain stress envelope for the environmental tests (i.e. dissipated temperature, power consumption, field radiation, etc.).

Test Software shall be developed to exercise the hardware in performing the environmental tests in the worst-case conditions and/or most sensitive configurations in order to evaluate the robustness of the IMA module over the full Usage Domain. For example, the Test Software should exercise all the physical interfaces with a maximum number of applications or inputs, and with filter values set to the domain boundary which would be the most transparent to any input electrical interference.

Chapter 2 — Applicable Test Procedures

For an ETSO-C153a authorisation, the IMA module may be a single Line Replaceable Unit (LRU) platform or may be a Line Replaceable Module (LRM) located in a Rack.

Depending on the characteristics of the IMA module, the applicant should consider one of the two following cases as appropriate:

- Case 1: the IMA module is a single LRU platform; and
- Case 2: the IMA module is a module designed to be located in a Rack at installation.

Note: The Rack Housing module is not addressed in this generic Appendix but in the relevant Appendix 2.2 — Class RH: Rack Housing.

Chapter 2.1 — The IMA module is a single LRU platform

In this case, the environmental sections defined in the Table below (Figure 26) are applicable to the IMA module.

The usage domain of the IMA module must be defined and maintained so that all the environmental qualification tests listed below produce a complete credit for all other functional ETSOs authorisations, or for the TC level.

Environmental Test	ED-14/DO-160 Section	Requirement for ETSO-C153a
Temperature	4.5	Mandatory
Altitude	4.6	Mandatory
Temperature Variation	5.0	Mandatory

Environmental Test	ED-14/DO-160 Section	Requirement for ETSO-C153a
Humidity	6.0	Mandatory
Shock (operational)	7.2	Mandatory
Shock (Crash Safety)	7.3	Optional
Vibration	8.0	Mandatory
Explosion Atmosphere	9.0	Optional
Waterproof	10.0	Optional
Fluids Susceptibility	11.0	Optional
Sand and Dust	12.0	Optional
Fungus Resistance	13.0	Optional
Salt Fog	14.0	Optional
Magnetic Effect	15.0	Mandatory
Power Input	16.0	Mandatory
Voltage Spike	17.0	Mandatory
Audio Frequency Conducted Susceptibility — Power Input	18.0	Mandatory
Induced-Signal Susceptibility	19.0	Mandatory
Radio Frequency Susceptibility (radiated and conducted)	20.0	Mandatory
Emission of Radio Frequency Energy	21.0	Mandatory
Lightning-Induced Transient Susceptibility	22.0	Mandatory
Lightning Direct Effects	23.0	Optional
Icing	24.0	Optional
Electrostatic Discharge (ESD)	25.0	Mandatory
Fire, Flammability	26.0	Mandatory

Figure 26 — Environmental Qualification for ETSO-C153a in the case of a single LRU platform

Chapter 2.2 — The IMA module is a module designed to be located in a Rack at installation or the rack itself.

In this type of envisioned installation, only a minimal subset of environmental conditions is applicable to the IMA module. This minimal subset is defined as mandatory in the table below (Figure 27).

Test sections identified as optional are not required for an ETSO-C153a application. Nevertheless, the IMA module can be subjected to these test conditions on a voluntary basis. When optional sections are not tested, they shall be marked with ‘X’.

The Environmental Qualification Testing (EQT) will be completed after cabinet integration in the frame of some other functional ETSOs authorisation, or of a TC level.

The usage domain of the IMA module must be defined and maintained so that at least this subset of qualification tests produces some credit for other ETSOs authorisations and for the TC level.

Note: It is acceptable to perform the environmental qualification on the intended rack installation equipped with (a) mounted IMA module(s). The ETSO-C153a IMA module should be set in worst-case configurations. By doing so, the set of Qualification documents (Qualification Test Plans, Procedures and Reports) may be common to both the rack and the module ETSO-C153a authorisations. These documents should demonstrate that the considered configurations (which may differ depending on the different sections of EUROCAE ED-14/RTCA DO-160) are the worst-cases for the set of authorised modules configurations within the rack. Whatever the qualification method used, the authorised configuration should be specified in the installation manual(s).

Such documented authorised configurations include any installation limitations that are taken as hypotheses for the EQT (rack part number(s), slot number(s), blade neighbourhood(s), and temperature to be guaranteed), and need to be specified in the Installation Manual and respected by the integrator so that he/she can take credit for the EQT performed at module level.

Environmental Test	ED-14/O-160 Section	Requirement for ETSO-C153a
Temperature	4.5	<p>Mandatory</p> <p>When the module performance under environmental conditions is dependent on the host rack, it is the responsibility of the applicant to adapt the ED-14/DO-160 high and low temperature values and temperature variations cycles to the intended IMA module installation context. For example, in the case of temperature testing (Section 4.0 of EUROCAE ED-14/RTCA DO-160), the temperature environment of the module (inside a rack) may be much higher or lower than the equipment level condition expressed in the aforementioned Section 4.0. Therefore, the applicant may qualify their IMA module based on a chosen intended environment, and, finally, indicate in the installation manual the temperature range for which the correct operation of the IMA module is guaranteed.</p>
Altitude	4.6	Mandatory
Temperature Variation	5.0	<p>Mandatory</p> <p>As for Section 4.5, when module performance under environmental conditions is dependent on the host rack, it is the responsibility of the applicant to adapt the ED-14/DO-160 high and low temperature values and temperature variations cycles to the intended IMA module installation context. As for Section 4.5, for example, in the case of temperature testing (Section 4.0 of EUROCAE ED-14/RTCA DO-160), where the temperature environment of the module (inside a rack) may be much higher or lower than the equipment-level condition as expressed in Section 4.0 of EUROCAE ED-14/RTCA DO-160, the applicant can qualify their IMA module based on a chosen intended environment, and, finally, indicate in the installation manual the temperature range for which the correct operation of the IMA module is guaranteed.</p>
Humidity	6.0	Mandatory
Shock (operational)	7.2	Optional
Shock (Crash Safety)	7.3	Optional
Vibration	8.0	<p>Optional</p> <p>Note: The IMA module technology should be assessed for further vibration qualification (ED-14/DO-160). This preliminary assessment could consider the IMA technology diversity of the module components, as well as the integration density and number of layers of the circuit boards within the IMA module. The assessment could be confirmed by testing on a module representative of the IMA module technology used in the product under certification. This preliminary assessment of the IMA module technology under vibration conditions does not constitute a credit for the qualification testing of the module integrated into the rack.</p>

Environmental Test	ED-14/O-160 Section	Requirement for ETSO-C153a
Explosion Atmosphere	9.0	Optional
Waterproof	10.0	Optional
Fluids Susceptibility	11.0	Optional
Sand and Dust	12.0	Optional
Fungus Resistance	13.0	Optional
Salt Fog	14.0	Optional
Magnetic Effect	15.0	Optional
Power Input	16.0	Mandatory for IMA module interfaces directly connected to the aircraft power distribution. Note: IMA module interfaces not directly connected to the aircraft power distribution will be tested after the cabinet integration phase as part of another ETSO application or as part of a Type Certification programme.
Voltage Spike	17.0	Mandatory for IMA module interfaces directly connected to the aircraft power distribution. Note: IMA module interfaces not directly connected to the aircraft power distribution will be tested after the cabinet integration phase as part of another ETSO application or as part of a Type Certification programme.
Audio Frequency Conducted Susceptibility — Power Input	18.0	Mandatory for IMA module interfaces directly connected to the aircraft power distribution. Note: IMA module interfaces not directly connected to the aircraft power distribution will be tested after the cabinet integration phase as part of another ETSO application or as part of a Type Certification programme.
Induced-Signal Susceptibility	19.0	Mandatory for IMA module interfaces directly connected to the aircraft wiring. Note: IMA module interfaces not directly connected to the aircraft wiring will be tested after the cabinet integration phase as part of another ETSO application or as part of a Type Certification programme.
Radio Frequency Susceptibility (radiated and conducted)	20.0	Mandatory for the conducted susceptibility of IMA module interfaces directly connected to the aircraft wiring. Note: IMA module interfaces not directly connected to the aircraft wiring will be tested after the cabinet integration phase as part of another ETSO application or as part of a Type Certification programme.
Emission of Radio Frequency Energy	21.0	Mandatory for the conducted emission of IMA module interfaces directly connected to the aircraft wiring. Note: IMA module interfaces not directly connected to the aircraft wiring will be tested after the cabinet integration phase as part of another ETSO application or as part of a Type Certification programme.
Lightning-Induced Transient Susceptibility	22.0	Mandatory for IMA module interfaces directly connected to the aircraft wiring. Note: IMA module interfaces not directly connected to the aircraft wiring will be tested after the cabinet integration phase as part of another ETSO application or as part of a Type Certification programme.
Lightning Direct Effects	23.0	Optional

Environmental Test	ED-14/O-160 Section	Requirement for ETSO-C153a
Icing	24.0	Optional
Electrostatic Discharge (ESD)	25.0	Mandatory for all areas subject to human contact during IMA module operation.
Fire, Flammability	26.0	Mandatory

Figure 27: Environmental Qualification Testing minimum subset for ETSO-C153a in for cabinet architectures

Chapter 3 — MPS compliance during EQT

When required by the test conditions and procedure (by the ‘DETERMINE COMPLIANCE WITH EQUIPEMENT PERFORMANCE STANDARDS’ statement), the IMA module manufacturer must determine compliance with the MPS as defined under the column ‘Test under environmental conditions’ of each individual class in Appendix 2:

MPS CLASS	MPS paragraph under Environmental Qualification Testing
All Classes (Common)	Appendix 2.1, paragraph 5
RH (Rack)	Appendix 4 is not applicable to this class. See Appendix 2.2, paragraph 3 under columns ‘Test under environmental conditions’ and ‘Applicable ED-14/DO-160 sections’.
PR (Processing)	Appendix 2.3, paragraph 3
GP (Graphical Processing)	Appendix 2.4, paragraph 3
DS (Data Storage)	Appendix 2.5, paragraph 3
IF (Interface)	Appendix 2.6, paragraph 3
PS (Power Supply)	Appendix 2.7, paragraph 3
DH (Display Head)	Appendix 2.8, paragraph 3

Figure 28 — MPS verification under environmental conditions

[Amdt ETSO/10]

[Amdt ETSO/16]

ETSO-C159d

ED Decision 2020/011/R (applicable from 25.7.2020)

NEXT GENERATION SATELLITE SYSTEMS (NGSS) EQUIPMENT

1 Applicability

This ETSO provides the requirements which next generation satellite systems (NGSS) equipment that is designed and manufactured on or after the date of this ETSO must meet in order to be identified with the applicable ETSO marking.

2 Procedures

2.1 General

The applicable procedures are detailed in CS-ETSO, [Subpart A](#).

2.2 Specific

None.

3 Technical Conditions

3.1 Basic

3.1.1 Minimum Performance Standard

The standards are those provided in EUROCAE ED-243 ‘Minimum Operational Performance Standards for Avionics Supporting Next Generation Satellite Systems (NGSS)’, dated April, 2017.

Note: *There are no MPS security requirements for NGSS equipment. However, a security risk assessment may be required at the time of installation, and if needed, security controls may be implemented in connected aircraft systems or addressed by flight crew procedures.*

3.1.2 Environmental Standard

See CS-ETSO, [Subpart A](#), paragraph 2.1.

3.1.3 Software

See CS-ETSO, [Subpart A](#), paragraph 2.2.

3.1.4 Airborne Electronic Hardware

See CS-ETSO, [Subpart A](#), paragraph 2.3.

3.2 Specific

The MPS allows for different equipment classes and subclasses as defined by EUROCAE ED-243. There are 6 applicable equipment classes and 11 equipment subclass components identified as shown in Tables 1A, 1B and Tables 2A, 2B of this ETSO. Tables 1A and 2A show the requirements for satellite communication (short burst data) (SATCOM (SBD)) equipment classes and subclass components, and Tables 1B and 2B show the requirements for satellite communication (swift Broadband) (SATCOM (SBB)) equipment classes and subclass components. The manufacturer must declare the equipment class requirements from those identified in the applicable table of this ETSO. The equipment configuration shall satisfy the relevant requirements of the EUROCAE ED-

243 minimum operational performance standards (MOPS) as identified in Tables 1A and 1B and 2A and 2B of this ETSO.

Table 1A — Equipment Class Identifiers supporting SATCOM (SBD)

Equipment Class Identifier	Description	Requirement
AES1	AES using a single channel Satellite Data Unit (SDU) that contains one transceiver for data only applications. AES1 is a Short Burst Data (SBD)-only transceiver and cannot support voice calling. A passive Low Gain Antenna (LGA) is required for use with the AES1.	Appendix D, Section 2.2.1.1 and Section 2.4 for the applicable test requirements
AES2	AES2 is capable of multiple services using a single or dual channel SDU that contains one or two transceivers for data and/or voice applications. A passive LGA is required for use with the AES2.	Appendix D, Section 2.2.1.2 and Section 2.4 for the applicable test requirements
AES3	AES using two or more transceivers for multiple data and/or voice applications. A passive LGA is required for use with the AES3.	Appendix D, Section 2.2.1.3 and Section 2.4 for the applicable test requirements

Table 1B — Equipment Class Identifiers supporting SATCOM (SBB)

Equipment Class Identifier	Description	Requirement
AES4	AES using an enhanced Low Gain Antenna (ELGA). AES4 configured as a complete system.	Appendix E, Section 2.2.1.1.1 and Section 2.4 for the applicable test requirements
AES6	AES using a High Gain Antenna (HGA), transceiver, and Diplexer Low Noise Amplifier (DLNA).	Appendix E, Section 2.2.1.1.2 and Section 2.4 for the applicable test requirements
AES7	AES using an Intermediate Gain Antenna (IGA), transceiver, and DLNA.	Appendix E, Section 2.2.1.1.3 and Section 2.4 for the applicable test requirements

Table 2A — Equipment Subclass Identifiers supporting SATCOM (SBD)

Subclass Identifier	Description	Requirement
LGA	Passive LGA for use with AES1, AES2 or AES3.	Appendix D, Section 2.2.3.1.1

Table 2B — Equipment Subclass Identifiers supporting SATCOM (SBB)

Subclass Identifier	Description	Requirement
HGA	HGA for AES6.	Appendix E, Section 2.2.3.1.2
IGA	IGA for AES7.	Appendix E, Section 2.2.3.1.2
6MA	Transceiver, SDU Configuration Module (SCM), SDU, Modified Type A (DMA) Diplexer Low Noise Amplifier (DLNA), and HGA for use with AES6.	Appendix E, Section 2.2.1.1.4
7MA	Transceiver, SDU, SCM, DMA DLNA, and IGA for use with AES7.	Appendix E, Section 2.2.1.1.6
6D	Transceiver and DLNA combination includes SDU, High-Power Amplifier (HPA), DLNA, SCM, and HGA functions for use with AES6.	Appendix E, Section 2.2.1.1.8
7D	Transceiver and DLNA combination includes SDU, HPA, DLNA, SCM, and IGA functions for use with AES7.	Appendix E, Section 2.2.1.1.9
6F	Transceiver and Type F (DF) DLNA includes SDU, HPA, SCM, and HGA functions for use with AES6.	Appendix E, Section 2.2.1.1.5
7F	Transceiver and DF DLNA includes SDU, HPA, SCM, and IGA functions for use with AES7.	Appendix E, Section 2.2.1.1.7
DMA	DLNA with standard Transmitter (Tx) filter configures with 6MA transceiver and HGA for use with AES6, or 7MA transceiver and IGA for use with AES7.	Appendix E, Section 2.2.1.1.10

Subclass Identifier	Description	Requirement
DF	DLNA with enhanced Tx filter configures with 6MA or 6F transceiver and HGA for use with AES6, or with 7MA or 7F transceiver and IGA for use with AES7.	Appendix E, Section 2.2.1.1.11

This ETSO standard applies to equipment intended for long-range communication services, procedural and continental communication services, aeronautical mobile satellite (route) services (AMS(R)S) by means of satellite communications between AES, corresponding satellites, and ground earth stations (GES). The NGSS supports voice and data communications between aircraft users and ground-based users, such as air navigation service providers (ANSPs) and aircraft operators.

The functionality of an NGSS supports four categories of communication service in the aircraft control domain (ACD) and/or aircraft information services domain (AISD). Two are safety of flight communication used for air traffic services (ATS) and aeronautical operational control (AOC) communication. The other two are aeronautical administrative communication (AAC) and special-purpose aeronautical passenger communication (APC) under the physical or virtual access control of the flight crew.

EUROCAE ED-243, Normative Appendix E, also contains provisions for supporting a non-priority communications service known as passenger information and entertainment services (PIES). EUROCAE ED-243, Normative Appendix E, states that non-priority services are outside the scope of that Appendix. However, PIES communications, if supported, must be partitioned from communications in the ACD and AISD for security reasons. Therefore, PIES communications are non-ETSO functions, and equipment that supports shared ACD and PIES communications must provide security partitioning of the PIES functionality from priority communications services in the ACD and AISD in accordance with this ETSO.

See paragraphs 3.1.3, 3.1.4 and 3.2.1 of this ETSO for specific additional data, design/security assurance and verification requirements related to the required security partitioning for equipment intended to support shared ACD/AISD and PIES communications.

NGSS equipment is intended for procedural/continental airspace area operations. The failure conditions specified in paragraph 3.2.1 of this ETSO have been determined based on NGSS equipment that supplements or complements primary HF/VHF voice or data communications in procedural/continental airspace area operations, and on equipment that provides ‘Segregation & arbitration’ as described in EUROCAE ED-243, Appendix E, Section 1.3.4, or the equivalent functionality. Use of NGSS equipment in other operating environments (for example, high-density terminal/en route airspace) may impact equipment performance and safety considerations.

3.2.1 Failure Condition Classification

See CS-ETSO, [Subpart A](#), paragraph 2.4.

A loss or malfunction of the security partitioning required by paragraph 3.2 of this ETSO that enables unauthorised or inadvertent access to ACD or AISD communications from outside the ACD or AISD is a major failure condition.

A loss or malfunction of the functions defined in paragraph 3.1.1 of this ETSO, except for a loss or malfunction of the security partitioning required by paragraph 3.2 of this ETSO, is a minor failure condition.

Note: The use of NGSS equipment as the sole means of routine ATS communication may change the classification of the failure conditions.

4 Marking

4.1 General

See CS-ETSO, [Subpart A](#), paragraph 1.2.

4.2 Specific

For valid combinations of system component markings, see Table 3 below.

Table 3 — Valid Combinations of System Components

Valid Combinations		EUROCAE ED-243 Normative Appendix	Transceiver					Transceiver & DLNA		DLNA		Antenna			Complete System	
			SBD	LBT	6MA	6F	7MA	7F	6D	7D	DMA	DF	LGA (passive)	HGA		IGA
AES1	1	D														x
	2	D	x									x				
AES2	3	D														x
	4	D		x								x				
AES3	5	D														x
	6	D	x	x								x				
AES4	1	E														x
AES6	2	E			x					x			x			
	3	E				x					x		x			
	4	E						x					x			
	5	E			x						x		x			
	6	E														x
AES7	7	E					x			x					x	
	8	E						x			x				x	
	9	E							x						x	
	10	E					x				x				x	
	11	E														x

5 Availability of Referenced Documents

See CS-ETSO, [Subpart A](#), paragraph 3.

[Amdt ETSO/11]

[Amdt ETSO/13]

[Amdt ETSO/16]

ETSO-C165b

ED Decision 2020/011/R (applicable from 25.7.2020)

ELECTRONIC MAP SYSTEMS FOR GRAPHICAL DEPICTION OF AIRCRAFT POSITION

1 Applicability

This ETSO provides the requirements that any electronic map system for the graphical depiction of aircraft position (own-ship), designed and manufactured on or after the date of this ETSO, must meet in order to be identified with the applicable ETSO marking.

This ETSO applies to equipment that is intended to provide graphical depiction of advisory information on a display (e.g. navigation, traffic, weather, obstacles, graphical taxi routing, etc.). The system is intended to improve flight crew positional awareness of the aircraft own-ship position relative to other items depicted on the display.

2 Procedures

2.1 General

The applicable procedures are detailed in CS-ETSO [Subpart A](#).

2.2 Specific

Applications to certify only the software without certifying the hardware and/or the operating system will be accepted. Nevertheless, the applicant has to specify the requirements for the hardware and/or the operating system to be used, the tests to be performed once the software is integrated into the final system, and the environment which has been used to demonstrate functionality of the system.

2.3 Databases

If the article includes database(s), each database must be processed in accordance with the requirements in EUROCAE ED-76A, Standards For Processing Aeronautical Data, dated June 2015, or RTCA DO-200B, Standards for Processing Aeronautical Data, dated 18 June 2015.

3 Technical Conditions

3.1 Basic

3.1.1 Minimum Performance Standard (MPS)

The applicable are those provided in Section 2 of RTCA document DO-257B, 'Minimum Operational Performance Standards for the Depiction of Navigational Information on Electronic Maps', dated 22 March 2018.

Electronic map systems may include displays, controls, and processing equipment that is intended to provide a graphical depiction of navigation information on the display (e.g. flight plans, fixes, nav aids, electronic charts, terrain, weather, obstacles, aerodrome surfaces, graphical taxi routing, etc.). The electronic map system improves flight crew positional awareness of the aircraft relative to other items depicted on the display. The standards were updated to support required navigation performance (RNP) systems, specifically when the in-flight (plan view) and vertical situation display (VSD) maps are displaying defined paths that are generated by the RNP system.

Table 1 provides the RTCA DO-257B requirements that are applicable to each specific function of the electronic map systems.

Electronic Map System functional description	Applicable Requirements Sections in RTCA DO-257B				
	2.1	2.2	2.3	2.4	2.5
In flight (Plan View Display)	X	X	X		
Aerodrome Moving Map (AMM)	X	X		X	
Vertical Situation Display (VSD)	X	X			X

Table 1

Displays that are part of the electronic map system must also be approved in accordance with ETSO-C113().

3.1.2 Environmental Standard

See CS-ETSO, [Subpart A](#), paragraph 2.1.

3.1.3 Software

See CS-ETSO, [Subpart A](#), paragraph 2.2

3.1.4 Airborne Electronic Hardware

See CS-ETSO, [Subpart A](#), paragraph 2.3

3.2 Specific

3.2.1 Failure Condition Classification

See CS-ETSO, [Subpart A](#), paragraph 2.4. RTCA DO-257B Section 2.1.8 defines the minimum failure condition classifications for the specific electronic map system functions that are summarised in Table 1, except for the loss of the aerodrome moving map display, which is a minor failure condition.

Failure of the functions defined in paragraph 3.1.1 of this ETSO for Electronic Map Systems used in flight and VSD equipment (airborne applications) have been determined to be a major failure condition for malfunctions causing the incorrect depiction of aircraft position (own-ship).

3.2.2 Documentation

Installation procedures and limitations must include:

- a description of the intended function of the electronic map system;
- a description of the data quality characteristics that are necessary for the electronic map system to perform its intended function (reference EUROCAE ED-76A Standards For Processing Aeronautical Data, dated June 2015, Section 2.3, or RTCA DO-200B, Standards for Processing Aeronautical Data, dated 18 June 2015, Section 2.3);
- a requirement to interface the electronic map system with a TSO or ETSO-approved global navigation satellite system (GNSS) sensor, which is the source of position input data;
- if applicable, a description of how the electronic map system with AMM meets the total system accuracy requirements of RTCA DO-257B, Section 2.4.1.1; and

- a requirement stating that the aeronautical database(s) associated with the electronic map system, whether internal or external to the electronic map system, must demonstrate compliance with EUROCAE ED-76A/RTCA DO-200B, or its subsequent revisions as required in paragraph 2.3 of this ETSO.

4 Marking

4.1 General

See CS-ETSO, [Subpart A](#), paragraph 1.2

4.2 Specific

None.

5 Availability of Referenced Documents

See CS-ETSO, [Subpart A](#), paragraph 3

[Amdt ETSO/6]

[Amdt ETSO/9]

[Amdt ETSO/16]

ETSO-C168*ED Decision 2020/011/R (applicable from 25.7.2020)***AVIATION VISUAL DISTRESS SIGNALS****1 Applicability**

This ETSO provides the requirements which aviation visual distress signals that are designed and manufactured on or after the date of this ETSO must meet in order to be identified with the applicable ETSO marking.

2 Procedures**2.1 General**

The applicable procedures are detailed in CS-ETSO, Subpart A.

2.2 Specific

None.

3 Technical Conditions**3.1 Basic****3.1.1 Minimum Performance Standard**

For handheld, high-intensity, stroboscopic light sources that can be added to aviation survival kits to supplement pyrotechnic devices, the standards are those provided in SAE International's Aerospace Standard AS5134A, Aviation Distress Signal, dated 27 September 2007.

3.1.2 Environmental Standard

See CS-ETSO, Subpart A, paragraph 2.1.

3.1.3 Software

See CS-ETSO, Subpart A, paragraph 2.2.

3.1.4 Airborne Electronic Hardware

See CS-ETSO, Subpart A, paragraph 2.3.

3.2 Specific**3.2.1 Failure Condition Classification**

See CS-ETSO, Subpart A, paragraph 2.4.

3.2.2 Others

These light sources must:

- eliminate the significant potential equipment and personnel hazards that are posed by untrained personnel using pyrotechnics in inflatable life rafts; and
- provide an equivalent level of safety to pyrotechnics that aid in locating and rescuing aviation accident survivors.

4 Marking

4.1 General

See CS-ETSO, Subpart A, paragraph 1.2.

4.2 Specific

None.

5 Availability of Referenced Documents

See CS-ETSO, Subpart A, paragraph 3.

[Amdt ETSO/16]

ETSO-C179b

ED Decision 2020/011/R (applicable from 25.7.2020)

RECHARGEABLE LITHIUM CELLS, BATTERIES, AND BATTERY SYSTEMS

1 Applicability

This ETSO provides the requirements which rechargeable lithium cells, batteries, and battery systems that are designed and manufactured on or after the date of this ETSO must meet in order to be identified with the applicable ETSO marking.

2 Procedures

2.1 General

The applicable procedures are detailed in CS-ETSO, [Subpart A](#).

2.2 Specific

None.

3 Technical Conditions

3.1 Basic

3.1.1 Minimum Performance Standard

For equipment with rechargeable lithium cells, lithium batteries and battery systems that are intended to provide power for aircraft equipment, including emergency systems, the applicable standards are those provided in RTCA document DO-311A, Minimum Operational Performance Standards for Rechargeable Lithium Batteries and Battery Systems, dated 19 December 2017. However, the demonstration of compliance with this ETSO may not rely on Appendix C to DO-311A.

3.1.2 Environmental Standard

Test the equipment according to Section 3 of RTCA document DO-311A, Minimum Operational Performance Standards for Rechargeable Lithium Batteries and Battery Systems, dated 19 December 2017.

3.1.3 Software

See CS-ETSO, [Subpart A](#), paragraph 2.2.

3.1.4 Airborne Electronic Hardware

See CS-ETSO, [Subpart A](#), paragraph 2.3.

3.2 Specific

3.2.1 Failure Condition Classification

See CS-ETSO, [Subpart A](#), paragraph 2.4.

4 Marking

4.1 General

See CS-ETSO, [Subpart A](#), paragraph 1.2.

4.2 Specific

The specific marking requirements are detailed in Section 2.1.3 of RTCA document DO-311A, Minimum Operational Performance Standards for Rechargeable Lithium Battery Batteries and Systems document, dated 19 December 2017.

In addition, the article must be marked with:

- its serial number;
- ‘ETSO-C179b-CLASS A-XY’ or ‘ETSO C179b-CLASS B-XY’ as shown below (where X stands for the energy category and Y stands for the venting category as listed in the table below and defined in RTCA document DO-311A Sections 1.4.1 and 1.4.2):
 - ETSO-C179b CLASS A — During the RTCA document DO-311A Section 2.4.5.5 Battery Thermal Runaway Containment Test, all the cells within the battery must undergo thermal runaways.
 - ETSO-C179b CLASS B — During the RTCA document DO-311A Section 2.4.5.5 Battery Thermal Runaway Containment Test, not all the cells within the battery must undergo thermal runaways.

Energy Category (X)	Venting Category (Y)
1	A
1	B
1	C
2	A
2	B
2	C
3	A
3	B
3	C
4	A
4	B
4	C

(For example: ETSO-C179b CLASS B-1A would be a rechargeable lithium battery and battery system that is of energy category 1 and a venting category of A, and not all the cells underwent thermal runaways during the RTCA document DO-311A Section 2.4.5.5 testing.)

5 Availability of Referenced Documents

See CS-ETSO, [Subpart A](#), paragraph 3.

[Amdt ETSO/7]

[Amdt ETSO/16]

ETSO-C196b*ED Decision 2020/011/R (applicable from 25.7.2020)***AIRBORNE SUPPLEMENTAL NAVIGATION SENSORS FOR GLOBAL POSITIONING SYSTEM
EQUIPMENT USING AIRCRAFT-BASED AUGMENTATION****1 Applicability**

This ETSO provides the requirements which airborne supplemental navigation sensors for Global Positioning System equipment using aircraft-based augmentation that are designed and manufactured on or after the date of this ETSO must meet in order to be identified with the applicable ETSO marking.

Note: Revision b provides applicants with the option to use an ETSO-2C206 GNSS circuit card assembly (CCA) as part of their ETSO application. There is no technical change to the MOPS in comparison with ETSO-C196a.

2 Procedures**2.1 General**

The applicable procedures are detailed in CS-ETSO, [Subpart A](#).

2.2 Specific

This section applies only for ETSO articles that use an ETSO-2C206 GNSS CCA.

Applicants who use an ETSO-2C206 GNSS CCA will need to coordinate with their GNSS CCA supplier for at least the following aspects:

2.2.1 Access to the Information of the Selected ETSO-2C206 CCA

The applicant is responsible for establishing the necessary communication channels with the ETSO-2C206 holder company. Applicants who use an ETSO-2C206 SBAS CCA will need to coordinate with their SBAS CCA supplier to obtain the documentation that supports ETSO-2C206.

The applicant's organisation shall establish a means of communication to obtain timely notifications of design changes, open problem reports (at least the ones that impact the usage of the CCA), occurrence reports and airworthiness directives that affect or relate to the ETSO-2C206 article.

2.2.2 Assessment of Design Changes

The applicant shall perform an impact analysis of the design changes to the ETSO-2C206 article, and shall perform the necessary development life-cycle activities that are impacted by the ETSO-2C206 changes.

Note: If a major change (as assessed per point 21.A.611) is applied to the ETSO-2C206 article, which is installed in the ETSO-C196b article, it is also systematically considered to be major for the ETSO-C196b function.

2.2.3 Assessment and Reporting of Open Problem Reports (OPRs)

The applicant shall perform the assessment of the ETSO-2C206 CCA OPRs. The applicant shall report the resulting OPRs that affect the ETSO-C196b article.

3 Technical Conditions

3.1 Basic

3.1.1 Minimum Performance Standard

The applicable standards are those provided in the Radio Technical Commission for Aeronautics (RTCA) document DO-316, Minimum Operational Performance Standards (MOPS) for Global Positioning System/Aircraft Based Augmentation System Airborne Equipment, dated 14 April 2009, Section 2.

Use of an ETSO-2C206 GNSS CCA functional sensor

ETSO-196b applicants have the option to use an ETSO-2C206 GNSS CCA functional sensor. Applicants who choose to use an ETSO-2C206 GNSS CCA can take credit for certification compliance by virtue of the ETSO-2C206 ETSOA for:

- meeting the MPS Section 2.1 requirements;
- the development assurance of the hardware/software;
- the classification of the failure conditions;
- the MPS Section 2.3 performance testing (functional qualification), except that specified in Appendix 1 to this ETSO; and
- partial environmental testing performed on the ETSO-2C206 GNSS CCA.

After the integration of the ETSO-2C206 CCA in the ETSO-196b article, the applicant shall perform the testing described in Appendix 1. The applicant shall also complete the environmental qualification testing. The testing shall include the detailed functional test procedures delivered by the ETSO-2C206 GNSS CCA provider. This testing is required to address the paragraphs of this ETSO that are not covered by the items listed above.

Note: An end-use equipment manufacturer that uses an ETSO-2C206 SBAS CCA functional sensor assumes full responsibility for the design and the function under their ETSO-C196b authorisation.

3.1.2 Environmental Standard

See CS-ETSO, [Subpart A](#), paragraph 2.1.

Test to EUROCAE ED-14() Sections 9 and 26 are considered to be optional. Tests to Sections 10, 11, 12, 13, and 14 are required only when the component is installed on the outside of the aircraft, such as the antenna.

3.1.3 Software

See CS-ETSO, [Subpart A](#), paragraph 2.2.

Applicants who use ETSO-2C206 GNSS CCA functional sensors may use the ETSO 2C206 authorisation as substantiation for compliance with the software development assurance aspects of the CCA.

3.1.4 Airborne Electronic Hardware

See CS-ETSO, [Subpart A](#), paragraph 2.3.

Applicants who use ETSO-2C206 GNSS CCA functional sensors may use the ETSO 2C206 authorisation as substantiation for compliance with the hardware development assurance aspects of the CCA.

3.2 Specific

3.2.1 Failure Condition Classification

See CS-ETSO, [Subpart A](#), paragraph 2.4.

A failure of the function defined in paragraph 3.1.1 of this ETSO has been determined to be a major failure condition for a malfunction of oceanic/remote, en route and terminal navigation and lateral navigation (LNAV) approaches.

A failure of the function defined in paragraph 3.1.1 of this ETSO has been determined to be a minor failure condition for a loss of navigation of oceanic/remote, en route and terminal navigation and lateral navigation (LNAV) approaches.

Note: These failure condition classifications are considered to be the minimum classifications. Guidance for the installation of navigation systems at the aircraft level (e.g. Certification Specifications and Acceptable Means of Compliance for Airborne Communications, Navigation and Surveillance (CS ACNS)) could require a different failure condition classification.

3.2.2 Additional Specific

Barometric-aided Fault Detection and Exclusion (FDE). If the equipment uses barometric-aiding to enhance the availability of FDE, then the equipment must meet the requirements in RTCA document DO-316, Appendix G.

4 Marking

4.1 General

See CS-ETSO, [Subpart A](#), paragraph 1.2.

4.2 Specific

None.

5 Availability of Referenced Documents

See CS-ETSO, [Subpart A](#), paragraph 3.

[Amdt ETSO/7]

[Amdt ETSO/16]

Appendix 1 to ETSO-C196b – End-Use Equipment Manufacturer Tests for GNSS CCA functional PVT Sensors Used for Navigation and Non-Navigation Applications

ED Decision 2020/011/R

1. SCOPE

This Appendix describes the required supplementary equipment level testing, in addition to the environmental testing of RTCA document DO-316, Section 2.2, that the manufacturer of the end-use equipment is required to conduct in order to receive an ETSO-C196b authorisation if they use an ETSO-2C206 GNSS CCA functional sensor. These test procedures are intended to streamline and simplify the ETSO-C196b authorisation process for the manufacturer of the end-use equipment by allowing credit for the design and selected testing performed at the GNSS CCA functional sensor level. However, the manufacturer of the end-use equipment remains fully responsible for the design and control of the article per their ETSO-C196b authorisation.

2. GENERAL PRINCIPLES

- (a) The testing methods for GPS equipment have been standardised by RTCA document DO-316, and these serve as the basis for ETSO-C196b. RTCA document DO-316 was written to cover equipment that can be installed on aircraft. Section 2.2 specifically addresses the issues of the environment in which the equipment operates, and provides the approved test methods to validate its performance in this environment. Section 2.2 represents the RTCA consensus in identifying which RTCA document DO-316 requirements are sensitive to environmental effects. These requirements are listed in Table 2-2, referenced in Section 2.2.1.
- (b) The determination that a MOPS requirement is susceptible to the environment does not depend on whether or not the implementation is a GNSS CCA within an ETSO-C196b article. Only the sensitivity to the environment is affected. This is the same concept as an equipment enclosure that is designed to protect against a benign environment compared with one that is designed for a severe environment; the identification of the susceptible requirements is the same.
- (c) Therefore, this Appendix uses Table 2-2 of RTCA document DO-316, Section 2.2.1, to identify the MOPS requirements that are susceptible to environmental conditions for a GNSS CCA functional sensor in the end-use equipment. The focus is on the change in environment seen by the GNSS CCA functional sensor as a result of its installation in the end-use equipment. For example, other components inside the end-use equipment may radiate RF energy that could interfere with the GPS functions; therefore, the ambient testing performed at the CCA level is not equivalent to the tests performed in the end-use equipment. This is the basis for defining the Section 2.3 performance tests that need to be repeated by the manufacturer of the end-use equipment.
- (d) Table 2-2, referenced in RTCA document DO-316, Section 2.2.1, is the prime source to determine the MOPS performance requirements that are susceptible to environmental conditions. Based on that table, the susceptible requirements can be grouped into two categories: those that are susceptible to most types of environmental conditions (described in Section 3) and those that are susceptible to only a few (described in Section 4).

3. PERFORMANCE REQUIREMENTS THAT ARE SUSCEPTIBLE TO MOST ENVIRONMENTAL CONDITIONS

3.1. RTCA document DO-316: Accuracy, sensitivity and dynamic range

The RTCA document DO-316 requirements for accuracy (2.1.3.1) and for sensitivity and dynamic range (2.1.1.10) are sensitive to most environmental conditions. Section 3 identifies the testing that manufacturers of end-use equipment are required to repeat to demonstrate that the GNSS CCA functional sensor continues to meet the accuracy and dynamic range performance requirements after installation in the end-use equipment. All the tests shall be run under conditions in which the functions of the end-use equipment are fully enabled to create the worst-case environment.

3.2. RTCA document DO-316: Section 2.3.6 Accuracy Test

- (a) The accuracy test described in Section 2.3.6 is actually a joint test that covers accuracy, sensitivity and dynamic range. This joint testing also applies under the environment as stated in Section 2.2.1.1.5, with the environmental adaptations as described in Section 2.2.1.1.1.
- (b) The demonstration of accuracy is performed in accordance with Section 2.3.6 only for the test case with broadband external interference noise. This test must be repeated when the GNSS CCA functional sensor is installed in the end-use equipment, and it is sufficient to perform it using broadband interference.
 - (1) The environmental testing is limited to broadband interference, as it represents the worst-case signal-to-noise condition, which is the most sensitive to environmental effects. This applies equally to the environment for the GNSS CCA functional sensor that is created by the end-use equipment.
 - (2) Section 2.3.6 contains a measurement accuracy test in 2.3.6.1, with the simulator and interference conditions described in 2.3.6.2, and the detailed test procedure in 2.3.6.2.1. The Section 2.3.6 test must be run under the worst-case environment identified in Section 5 'Additional considerations for internal interference sources' below.
 - (3) Section 2.3.6.3 is a 24-hour actual satellite accuracy test. The Section 2.3.6.3 test exposes the equipment to a variety of signal conditions and data-processing conditions over varying satellite geometries that will increase the confidence that no unforeseen interactions between the components within the end-use equipment and the GNSS CCA functional sensor will go undetected.
- (c) The test threshold is relaxed from 110 % to 125 %, as specified in Table 2-6 of the Section 2.3.6.2.1 test procedure, to shorten the duration of the test. However, the Section 2.3.6 testing for the GNSS CCA functional sensor in the end-use equipment shall be under the ambient conditions per Section 2.3 with the 110-% test pass threshold for maximum test sensitivity.
- (d) Only the broadband external interference noise test case using the minimum satellite power will be executed in most cases to shorten the duration of the test. The testing of Sections 2.3.6.1 and 2.3.6.2 will be repeated for both the minimum and the maximum satellite power only for the worst-case environment.

4. PERFORMANCE REQUIREMENTS THAT ARE PARTIALLY SUSCEPTIBLE TO ENVIRONMENTAL CONDITIONS

- (a) Table 2-2 in RTCA document DO-316 indicates that the acquisition time (2.1.1.7) and the reacquisition time (2.1.1.9) requirements are sensitive to four environmental conditions: icing, lightning-induced transient susceptibility, lightning direct effects, and normal/abnormal operating conditions. The requirements for loss of navigation (2.1.1.11.2) and loss of integrity (2.1.1.11.1) are sensitive to low and high operating temperatures.

Note: RTCA document DO-316 Table 2-2 contains a typo that erroneously numbers the loss of navigation and loss of integrity requirements as 2.1.1.13.2 and 2.1.1.13.1.

- (b) The lightning-induced transient susceptibility, lightning direct effects, or icing environmental conditions are not pertinent to the environment that is created by the end-use equipment relative to the GNSS CCA functional sensor. However, the manufacturer of the end-use equipment remains responsible for meeting the overall environmental qualification at the end-use equipment level.
- (c) Loss of navigation and loss of integrity indications are limited to temperature testing and the information in RTCA document DO-316, Sections 2.2.1.1.2 and 2.2.1.1.3, is appropriate. The purpose is to ensure that the interface that is used to indicate the loss of navigation or integrity is functional under the environmental conditions that are present after the GNSS CCA functional sensor is installed in the end-use equipment. Sections 2.2.1.1.2 and 2.2.1.1.3 indicate that any source that generates the indication can be used, since it is the interface and not the detection mechanism that is verified. The temperature testing performed at the end-use equipment level is the worst-case scenario. It is not necessary to repeat the GNSS CCA level test at room temperature in the end-use equipment since the environmental qualification adequately addresses the testing for these requirements.
- (d) EUROCAE ED-14 Section 16 relates to aircraft power supplies (refer to ETSO Section 3.1.2 for the environmental qualification requirements). Sections 16.5.1.2 and 16.6.1.2 are for normal/abnormal operating conditions. Given the potential susceptibility of the GNSS CCA functional sensor to power supply noise, it is prudent to repeat the tests at the end-use equipment level on this basis. Table 2-2, referenced in RTCA document DO-316, Section 2.2.1, does not guarantee the execution of specific acquisition testing.
- (e) Sections 4.1 and 4.2 identify the testing that manufacturers of end-use equipment are required to repeat to demonstrate that the GNSS CCA functional sensor continues to meet the acquisition time and reacquisition time performance requirements relative to the normal/abnormal operating conditions after installation in the end-use equipment. All the tests shall be run under conditions in which the functions of the end-use equipment are fully enabled to create the worst-case environment.

4.1. RTCA DO-316: Section 2.3.3 Initial Acquisition Test Procedures

The information in RTCA document DO-316, Section 2.2.1.1.4, on the initial acquisition test in Section 2.3.3, applies. The manufacturer of the end-use equipment shall repeat the initial acquisition testing described in RTCA document DO-316, Section 2.3.3.

4.2. RTCA document DO-316: Section 2.3.4 Satellite Reacquisition Time Test

The manufacturer of the end-use equipment is required to repeat the satellite reacquisition time testing in RTCA document DO-316, Section 2.3.4.

5. ADDITIONAL CONSIDERATIONS FOR INTERNAL INTERFERENCE SOURCES

- (a) Installing a GNSS CCA functional sensor into end-use equipment that also includes other functions requires a careful evaluation of the potential internally radiated and conducted interference. The manufacturer of the end-use equipment must evaluate each operating mode to determine whether the mode changes the environment for the installed GNSS CCA functional sensor. If there is only one environment or there is clearly one worst-case environment, then the accuracy and message loss rate testing in Section 3 can be run in that operating mode only. For example, if the end-use equipment includes an RF transmitter that radiates at one frequency, one could reasonably argue that setting the transmitter at full power with maximum data throughput would generate a clear worst-case environment in which to run all the testing.
- (b) In the case of multiple environments, the accuracy and message loss rate tests can either be run under each environment, or the methodology in RTCA document DO-316, Section 2.2.1.2.3, can be used to run an aggregate with approximately equal time in each mode. The methodology in Section 2.2.1.2.3 must be used to identify the modes of greatest susceptibility under which the combined accuracy and message loss rate tests are repeated in addition to the aggregate test. For example, the 2.2.1.2.3 methodology is appropriate for end-use equipment that contains a high-power transmitter that operates on a large number of frequencies such that it is impractical to run a test at each frequency. This is analogous to the large number of frequencies that need to be tested during the EUROCAE ED-14 Section 19 testing on induced signal susceptibility and the Section 20 testing on radio frequency susceptibility, and this is the reason why the Section 2.2.1.2.3 methodology was developed.
- (c) It is sufficient to identify one worst-case environment when performing acquisition and 24-hour accuracy testing.

6. SUMMARY

- (a) The manufacturer of end-use equipment that incorporates a GNSS CCA functional sensor is required to repeat the following RTCA document DO-316 Section 2.3 testing under ambient conditions (see paragraph 5) after installing the GNSS CCA functional sensor in the end-use equipment:
 - The Section 2.3.6 accuracy test adapted per Section 2.2.1.1.1, except that the 110 % test pass threshold is used.

Note: Refer to Section 5 ‘Additional considerations for internal interference sources’ of this Appendix, which could affect the test methodology.
 - The Section 2.3.3 initial acquisition test.
 - The Section 2.3.4 satellite reacquisition time test.
- (b) The manufacturer of the end-use equipment remains responsible for completing a full environmental qualification evaluation (see ETSO Section 3.1.2) at the end-use equipment level. The manufacturer of the end-use equipment that incorporates a GNSS CCA functional sensor is required to repeat the Loss of Navigation and Loss of

Integrity indication environmental testing according to RTCA document DO-316, Sections 2.2.1.1.2 and 2.2.1.1.3.

[Amdt ETSO/16]

ETSO-C199 A1

ED Decision 2020/011/R (applicable from 25.7.2020)

TRAFFIC AWARENESS BEACON SYSTEM (TABS)**1 Applicability**

This ETSO provides the requirements for the applicable equipment class defined by this ETSO which traffic awareness beacon systems (TABSs) that are designed and manufactured on or after the date of this ETSO must meet in order to be identified with the applicable ETSO marking.

TABS devices are distinctly different from other transponders. TABS devices are intended for voluntary equipage on aircraft that are exempted from carrying a transponder or automatic dependent surveillance — broadcast (ADS-B) equipment, such as gliders, balloons and aircraft without electrical systems. TABS devices do not meet the transponder or ADS-B requirements defined in Commission Implementing Regulation (EU) No 1207/2011 of 22 November 2011 laying down requirements for the performance and the interoperability of surveillance for the single European sky. TABS equipment built to the minimum requirements of this ETSO will enable an aircraft to be visible to other aircraft equipped with:

- a Traffic Advisory System (TAS) as defined in ETSO-C147();
- a Traffic Alert and Collision Avoidance System I (TCAS I) as defined in ETSO-C118();
- a Traffic Alert and Collision Avoidance System II, (TCAS II), as defined in ETSO-C119d;
- ADS-B IN capability as defined in ETSO-C154c, ETSO-C166b (), and ETSO-C195b.

2 Procedures**2.1 General**

The applicable procedures are detailed in CS-ETSO, [Subpart A](#).

2.2 Specific

None.

3 Technical conditions**3.1 Basic****3.1.1 Minimum Performance Standard**

TABS requirements are derived from existing transponder and ADS-B requirements. Equipment that only meets the minimum TABS requirements will provide the capability to be seen by other aircraft equipped with traffic advisory systems, but may not support its detection by ground surveillance systems that rely on full transponder functionality. A designer who builds equipment to meet this ETSO may decide to incorporate more capability than what is outlined in this ETSO, as long as it meets the applicable requirements in the referenced standards (e.g. EUROCAE ED-73E, MOPS for Secondary Surveillance Radar Mode S Transponders, as amended by [Appendix 1 to ETSO-C112e](#)).

TABS functionality is divided into four categories: the transponder function, the altitude source function, the ADS-B OUT function, and the position source function.

A Class A TABS:

- includes the transponder, altitude source, and ADS-B OUT functionality; refer to subparagraphs (a), (b), and (c) below;

- consists of a Class A device, or an ETSO-C112e and an ETSO-C166b-compliant device.

A Class B TABS:

- includes the Global Navigation Satellite System (GNSS) position source functionality; refer to subparagraph (d) below;
- consists of a Class B device, or an ETSO-C129a (cancelled), ETSO-C145c or later revision, ETSO-C146c or later revision, or an ETSO-C196b-compliant GPS.

A TABS may include an ADS-B IN function, but it is not required. If it is implemented, the ADS-B IN function shall meet the performance specified in ETSO-C195b as well as ETSO-C154c, or ETSO-C166b, or all three. A TABS is intended to make the aircraft a valid TIS-B and ADS-R client.

- (a) The transponder functionality must meet a subset of the requirements in document RTCA document DO-181E, MOPS for Air Traffic Control Radar Beacon System/Mode Select (ATCRBS/Mode S) Airborne Equipment, dated 17 March 2011, Section 2, for a Level 2, Class 2 transponder as amended by [Appendix 1](#).
- (b) The altitude source functionality must meet the requirements of ETSO-C88a or later revision, Automatic Pressure Altitude Reporting Code Generating Equipment, dated 5 August 2016.
- (c) The ADS-B OUT function must meet a subset of the requirements found in document EUROCAE ED-102A, Minimum Operational Performance Standards for 1090 MHz Extended Squitter Automatic Dependent Surveillance — Broadcast (ADS-B) and Traffic Information Services — Broadcast (TIS-B), dated December 2009, including Corrigendum-1, Section 2, dated January 2012, Class B0 as amended by [Appendix 1](#). The system must be built such that it transmits Navigation Integrity Code (NIC), Navigation Accuracy Category for Position (NACp), Navigation Accuracy Category for Velocity (NACv), Geometric Vertical Accuracy (GVA), and Safety Integrity Level (SIL) values that are appropriate for the GNSS receiver used.
- (d) The position source function must use a GNSS receiver that meets the requirements defined in [Appendix 1](#). The intent of this ETSO is to allow the use of commercially available GNSS position sources. The receiver must be capable of using SBAS-provided corrections and health messages, as defined in [Appendix 1](#), in order to provide a means to prevent the TABS from transmitting false or misleading information. The receiver may continue to provide position when outside of SBAS coverage or when using unmonitored satellites. TABS Class B position sources may not be used for certified navigation equipment.

3.1.2 Environmental Standard

See CS-ETSO, [Subpart A](#), paragraph 2.1.

For Class A equipment, demonstrate the required performance under the test conditions specified in RTCA document DO-181E Section 2.3 and EUROCAE ED-102A, including Corrigendum-1, Section 2.3, dated January 2012.

For Class B equipment, demonstrate the required performance under the test conditions specified in [Appendix 3](#).

3.1.3 Software

See CS-ETSO, [Subpart A](#), paragraph 2.2.

This requirement applies to Class A equipment only. Class B equipment is exempt from the software qualification defined in this paragraph.

3.1.4 Airborne Electronic Hardware

See CS-ETSO, [Subpart A](#), paragraph 2.3.

This requirement applies to Class A equipment only. Class B equipment is exempt from the electronic hardware qualification defined in this paragraph.

3.2 Specific

3.2.1 Failure Condition Classification

See CS-ETSO, [Subpart A](#), paragraph 2.4.

A failure of the function defined in paragraph 3.1.1 of this ETSO that results in misleading information is a minor failure condition.

A failure of the function defined in paragraph 3.1.1 of this ETSO that results in a loss of function is a minor failure condition.

Class B equipment is intended to be met by commercially available GNSSs and is unlikely to be designed specifically to support a minor hazard classification. The suitability of Class B equipment suitability for supporting the function in paragraph 3.1.1 of this ETSO is established by performing the functional and environmental testing in [Appendix 2](#) and [Appendix 3](#) to this ETSO with no further analysis required.

4 Marking

4.1 General

See CS-ETSO, [Subpart A](#), paragraph 1.2.

4.2 Specific

None.

5 Availability of Referenced Documents

See CS-ETSO, [Subpart A](#), paragraph 3.

EUROCONTROL Documents: EUROCONTROL, STA/R/460/0001/1, Study to Address the Detection and Recognition of Light Aircraft in the Current and Future ATM Environment, Issue 1.0, Final Report, dated 31 March 2005.

FCC Documents: Federal Communication Commission document OET Bulletin 65 Ed 97-01, Evaluating Compliance with FCC Guidelines for Human Exposure to Radiofrequency Electromagnetic Fields is available on the internet at:

http://transition.fcc.gov/Bureaus/Engineering_Technology/Documents/bulletins/oet65/oet65.pdf

UK Public Health Documents Public Health England document HPA-RPD-031, Exposure to EMFs from Lightweight Aviation Transponders, dated September 2007, ISBN 978-0-85951-605-1, can be obtained on line by going to:

<http://www.hpa.org.uk/Publications/Radiation/HPARPDSeriesReports/HpaRpd031/>

Global Positioning System Signals, Measurements, and Performance, Ganga-Jamuna Press, by Pratap Misra and Per Enge. ISBN: 0-9709544-0-9

[Amdt ETSO/13]

[Amdt ETSO/16]

Appendix 1 to ETSO-C199 A1 – Traffic Awareness Beacon System (TABS) Requirements

ED Decision 2020/011/R

A1 Introduction

A1.1 TABS Intent

A1.1.1 The intent of a TABS is to increase safety by encouraging the voluntary equipage of a low-cost, compact, easy-to-install device that will allow other aircraft equipped with collision avoidance systems and traffic advisory systems to track and display the TABS aircraft. TABSs are intended to be used on aircraft that are exempted from carrying a transponder or Automatic Dependent Surveillance — Broadcast (ADS-B) equipment, such as gliders, balloons and aircraft without electrical systems. TABS devices do not meet the transponder requirements defined in Commission Implementing Regulation (EU) No 1207/2011 of 22 November 2011 laying down requirements for the performance and the interoperability of surveillance for the single European sky. A TABS will allow these exempted aircraft to be visible to other aircraft equipped with:

1. a Traffic Advisory System (TAS) as defined in ETSO-C147();
2. a Traffic Alert and Collision Avoidance System I (TCAS I) as defined in ETSO-C118();
3. a Traffic Alert and Collision Avoidance System II, (TCAS II), as defined in ETSO-C119d;
4. ADS-B IN capability as defined in ETSO-C166b, and ETSO-C195b; or
5. ADS-B IN capability as defined in ETSO-C154c in airspace where UAT is used.

A1.1.2 A TABS is designed to:

6. reply to ATRBS Mode C, and Mode S UF=0, 4, 5, 20 and 21 interrogations;
7. not reply to ATRBS Mode A interrogations;
8. not reply to Mode S UF=11, and 16 interrogations;
9. incorporate ETSO-C88b, Automatic Pressure Altitude Reporting Code-Generating Equipment;
10. transmit ADS-B Messages: Aircraft Identification and Category, Airborne Position, Airborne Velocity, Emergency Priority Status Message, and Aircraft Operational Status;
11. optionally provide Surface Position Messages;
12. optionally use a commercial GNSS source meeting the requirements of this ETSO.

A1.1.3 A TABS can potentially act as a low-cost platform for other aviation applications. Although additional capabilities are beyond the scope of this ETSO, TABSs may include additional functions such as data loggers, search and rescue transmitter, or provide flight information services.

A1.2 Requirements

A1.2.1 TABS requirements are derived from existing Mode S transponder and 1090 MHz Extended Squitter ADS-B requirements. A designer who builds equipment to meet this ETSO may decide to incorporate the full transponder and ADS-B capability by using a device that meets ETSO-C112e and ETSO-C166b. If they elect to implement the full functionality, they must demonstrate that functionality against the unmodified test procedures in EUROCAE ED-102A, including Corrigendum-1, dated January, 2012, that are required by ETSO-C112e and ETSO-C166b respectively. Designers who wish to take advantage of the reduced transponder requirements afforded to ETSO-C199 Class A devices must meet the modified requirements outlined in paragraphs A1.2.3 Transponder Function Requirements, A1.2.4 Altitude Source Function Requirements, and A1.2.5 ADS-B OUT Function Requirements in this

Appendix in their entirety. Designers wishing to take advantage of the Class B reduced GNSS requirements will need to meet the requirements outlined in paragraphs A1.2.6 GNSS Position Source Function Requirements.

A1.2.2 MOPS text is used here with the permission of the RTCA. Table 1 provides notes in italics and parenthesis explaining how to read the tables that modify the text in the source documents.

(Source document reference)	Modified text for this ETSO
(This is a copy of the original text from the source document. Material to be deleted from this original text is marked with strikethrough formatting .)	(This is the requirement for this ETSO. Modifications to the source text are marked in <u>bold and underlined</u> to assist in identifying changes).

Table 1 — (Source document reference) (type of change)

A1.2.3 Transponder Function Requirements Derived From DO-181E (For Class A Devices)

A1.2.3.1 The transponder function must meet the Minimum Performance Standards (MPS) qualification and documentation requirements in RTCA, Inc. document RTCA document DO-181E, Section 2, for a Level 2, Class 2, transponder as modified below.

A1.2.3.1.1 Flight Crew Control Function Changes

A1.2.3.1.2 A cost factor in any device is the control and display functions to interface with the human operator. TABS display and control requirements are a subset of those required for transponders. Some user controls are allowed via an external device prior to flight (e.g., a personal electronic device (PED)). If the system is powered by batteries, display of the available battery life is recommended. Table 2 provides an overview of the flight crew control functions.

Operation mode	Required Controls	Required Indicators
In flight (i.e., control head)	- Power, - Emergency (3/A code 7700), - IDENT (optional)	Power on, Transponder Fail, ADS-B Fail, Battery indicator (optional)
Non-flight (optional in flight) (i.e., Personal Electronic Device PED)	- Set 4096 code, - Set Flight ID	Display of 4096 code, Display of Flight ID
Maintenance actions (allowed in non-flight conditions only)	- Set ICAO 24-bit aircraft address, - Set implementation specific configuration	Display of ICAO 24-bit aircraft address, Display of implementation specific configuration. Display software version (optional)

Table 2 — Summary of Control and Indication Requirements by Operation Mode

A1.2.3.1.3 RTCA document DO-181E, Section 2.1.7.a, Flight Crew Control Functions, is amended as shown in Table 3.

DO-181E text	Modified text for this ETSO
The following functions Shall be provided a. A means of selecting each of the ATCRBS 4096 reply codes, and of indicating the code selected.	The following functions SHALL be provided <u>as indicated in items a-f.</u> a. A means of selecting <u>and displaying</u> the ATCRBS 4096 code <u>on the ground SHALL be provided. A means of selecting and displaying the ATCRBS 4096 code in flight is optional. A means of setting the Mode 3/A code to 7700 (emergency), either by entering in the value or an automated means such</u>

	<p><u>as a switch, SHALL be provided. A means of setting an alternate 4096 code other than the primary 4096 code, either by entering in the value or an automated means such as a switch, SHALL be provided.</u></p>
--	---

Table 3 — DO-181E Section 2.1.7.a amendment

A1.2.3.1.4 RTCA document DO-181E, Section 2.1.7.b, Flight Crew Control Functions, is amended as shown in Table 4.

DO-181E text	Modified text for this ETSO
<p>The following functions Shall be provided</p> <p>b. A means of selecting the air/ground state:</p> <p>1) An automatic means Shall be the only acceptable means to determine the air/ground state.</p> <p>2) If an automatic means is not available, the transponder Shall ensure that the air/ground state is Airborne</p>	<p>The following functions SHALL be provided <u>as indicated in items a-f.</u></p> <p>b. A means of selecting the air/ground state:</p> <p>1) An automatic means to determine the air/ground state <u>is recommended.</u></p> <p>2) If an automatic means is not <u>implemented</u>, the transponder SHALL ensure that the air/ground state is Airborne.</p>

Table 4 — DO-181E Section 2.1.7.b amendment

A1.2.3.1.5 RTCA document DO-181E, Section 2.1.7.c, Flight Crew Control Functions, is amended as shown in Table 5.

DO-181E text	Modified text for this ETSO
<p>The following functions Shall be provided</p> <p>c. A means of selecting the condition in which all transponder functions, other than transmission on the reply frequency and associated self-testing, are operational (i.e., the Standby condition). Return to normal operation from this condition Shall be possible within five seconds.</p>	<p>The following functions SHALL be provided <u>as indicated in items a-f.</u></p> <p>c. A means of selecting the condition in which all transponder functions, other than transmission on the reply frequency and associated self-testing, are operational (i.e., the Standby condition) <u>is not required. However, if provided</u>, return to normal operation from Standby condition SHALL be possible within five seconds.</p>

Table 5 — DO-181E Section 2.1.7.c amendment

A1.2.3.1.6 RTCA document DO-181E, Section 2.1.7.d, Flight Crew Control Functions, is amended as shown in Table 6.

DO-181E text	Modified text for this ETSO
<p>The following functions Shall be provided</p> <p>d. A means of initiating the IDENT (SPI) feature.</p>	<p>The following functions SHALL be provided <u>as indicated in items a-f.</u></p> <p>d. A means of initiating the IDENT (SPI) feature <u>is optional.</u></p>

Table 6 — DO-181E Section 2.1.7.d amendment

A1.2.3.2 Reply Rate Capability Changes

A1.2.3.2.1 This section reduces the minimum reply rate capability of the TABS consistently with the interrogation acceptance based on two assumptions. The following rationale describes how the modified reply rates were chosen.

A1.2.3.2.1.1 Assumption 1. The worst-case Mode C interrogation count in a 100-millisecond interval from 1 ATCRBS radar is approximately 14 interrogations. 4 ATCRBS radar overlapping beam dwells in 1 second is approximately 53 Mode C interrogations. The Mode C interrogation acceptance rate from 10 TCAS I units is approximately 15 interrogations per second. This represents a total demand on the TABS of 68 Mode C replies per second for this example.

A1.2.3.2.1.2 Assumption 2. The worst-case Mode S reply rate is primarily derived from the expected interrogation pattern of a set of 50 nearby TCAS II units all equipped with hybrid surveillance. The radar load from only roll-call interrogations would be small and would require networked sensors, otherwise the Mode S ground interrogation acceptance rate from radar systems would be 0 (zero).

A1.2.3.2.2 Based on assumptions 1 and 2, RTCA document DO-181E Section 2.2.3.4 Reply Rate Capability is changed as follows:

A1.2.3.2.2.1 RTCA document DO-181E, Section 2.2.3.4.1.a, ATCRBS Reply Rate Capability, is amended as shown in Table 7.

DO-181E text	Modified text for this ETSO
The transponder Shall be able to continuously generate at least 500 ATCRBS 15-pulse replies per second.	The transponder Shall be able to continuously generate at least <u>100</u> ATCRBS 15-pulse replies per second.

Table 7 — DO-181E Section 2.2.3.4.1.a amendment

A1.2.3.2.2.2 RTCA document DO-181E, Section 2.2.3.4.1.c, ATCRBS Reply Rate Capability, is amended as shown in Table 8.

DO-181E text	Modified text for this ETSO
For Class 2 equipment, the transponder Shall be capable of a peak reply rate of 1000 ATCRBS 15-pulse replies per second for a duration of 100 milliseconds.	For Class 2 equipment, the transponder SHALL be capable of a peak reply rate of <u>150</u> ATCRBS 15-pulse replies per second for a duration of 100 milliseconds.

Table 8 — DO-181E Section 2.2.3.4.1.c added

A1.2.3.2.2.3 RTCA document DO-181E, Section 2.2.3.4.2.a, Mode S Reply Rate Capability, is amended as shown in Table 9.

DO-181E text	Modified text for this ETSO
A transponder equipped for only short Mode S downlink formats (DF), Shall have the following minimum reply rate capabilities:	A transponder equipped for only short Mode S downlink formats (DF), SHALL have the following minimum reply rate capabilities:
50 Mode S replies in any 1-second interval.	<u>29</u> Mode S replies in any 1-second interval.
18 Mode S replies in a 100-millisecond interval.	<u>10</u> Mode S replies in a 100-millisecond interval.
8 Mode S replies in a 25-millisecond interval.	<u>5</u> Mode S replies in a 25-millisecond interval.
4 Mode S replies in a 1.6-millisecond interval.	<u>3</u> Mode S replies in a 1.6-millisecond interval.

Table 9 — DO-181E Section 2.2.3.4.a amendment

A1.2.3.2.2.4 RTCA document DO-181E, Section 2.2.3.4.2.b, Mode S Reply Rate Capability, is amended as shown in Table 10.

DO-181E text	Modified text for this ETSO
A transponder equipped for long Mode S reply formats Shall be able to transmit as long replies:	A transponder equipped for long Mode S reply formats SHALL be able to transmit as long replies:
At least 16 of the 50 Mode S replies in any 1-second interval.	At least 10 of the 29 Mode S replies in any 1-second interval.
At least 6 of the 18 Mode S replies in a 100 millisecond interval.	At least 4 of the 10 Mode S replies in a 100-millisecond interval.
At least 4 of the 8 Mode S replies in a 25 millisecond interval.	At least 3 of the 5 Mode S replies in a 25-millisecond interval.
At least 2 of the 4 Mode S replies in a 1.6 millisecond interval.	At least 2 of the 4 Mode S replies in a 1.6-millisecond interval.

Table 10 — DO-181E Section 2.2.3.4.2.b amendment

A1.2.3.3 Reply Rate Limiting Changes

A1.2.3.3.1 The modifications in this section address reply rate limiting for ATRCBS and Mode S reply rates consistently with the previous section.

A1.2.3.3.2 RTCA document DO-181E, Section 2.2.7.3.1, ATRCBS Reply Rate Limiting, is amended as shown in Table 11.

DO-181E text	Modified text for this ETSO
A sensitivity-reduction reply rate limit Shall be incorporated in the transponder for ATRCBS replies. The limit Shall be capable of being adjusted between 500 continuous ATRCBS Mode A and Mode C replies per second and the maximum continuous rate of which the transponder is capable, or 2000 replies per second, whichever is less, without regard to the number of pulses in each reply. Sensitivity reduction Shall apply only to the receipt of ATRCBS, ATRCBS/Mode S All-Call, and ATRCBS Only All-Call interrogations.	A sensitivity-reduction reply rate limit SHALL be incorporated in the transponder for ATRCBS replies. The limit SHALL be capable of being adjusted between 100 continuous ATRCBS Mode C replies per second and the maximum continuous rate of which the transponder is capable, or 200 replies per second, whichever is less, without regard to the number of pulses in each reply. Sensitivity reduction SHALL apply only to the receipt of ATRCBS interrogations.

Table 11 — DO-181E Section 2.2.7.3.1 amendment

A1.2.3.4 RTCA document DO-181E, Section 2.2.13.1.2.c, Variable Direct Data, is amended as shown in Table 12.

DO-181E text	Modified text for this ETSO
c. <u>On-the-Ground Condition</u> The transponder shall report the automatically determined on-the-ground state as determined by the aircraft in the Flight Status (FS), Vertical Status (VS), and Capability (CA) fields (see §2.2.14.4.15, §2.2.14.4.42, and §2.2.14.4.6), except when reporting airborne status when on-the-ground is reported to	c. <u>On-the-Ground Condition</u> The transponder may report the automatically determined on-the-ground state as determined by the aircraft in the Flight Status (FS), Vertical Status (VS), and Capability (CA) fields (see paragraphs 2.2.14.4.15, 2.2.14.4.42, and 2.2.14.4.6), except when reporting airborne status when on-the-ground is

the transponder under the conditions specified in §2.2.18.2.7.	reported to the transponder under the conditions specified in paragraph 2.2.18.2.7.
--	---

Table 12 — DO-181E Section 2.2.13.1.2.c amendment

A1.2.3.5 RTCA document DO-181E, Section 2.2.13.1.2.d, Variable Direct Data, is amended as shown in Table 13.

DO-181E text	Modified text for this ETSO
<p>d. Special Position Identification (SPI)</p> <p>In the ATCRBS mode, an SPI pulse shall be transmitted upon request, following a Mode A reply. In the FS field of Mode S replies, an equivalent of the ATCRBS SPI pulse shall be transmitted upon the same request. The code is transmitted for 18 ±1.0 seconds after initiation and can be reinitiated at any time.</p>	<p>d. Special Position Identification (SPI)</p> <p>In the FS field of Mode S replies, an equivalent of the ATCRBS SPI pulse shall be transmitted upon <u>request if the optional IDENT flight crew control is implemented per A1.2.3.1.6 of this ETSO.</u> The code is transmitted for 18 ± 1.0 seconds after initiation and can be reinitiated at any time.</p>

Table 13 — DO-181E Section 2.2.13.1.2.d amendment

A1.2.3.6 RTCA document DO-181E, Section 2.2.13.1.2.e, Variable Direct Data, is amended as shown in Table 14.

DO-181E text	Modified text for this ETSO
<p>e. Aircraft Identification Data</p> <p>If the aircraft uses a flight number for aircraft identification, a means shall be provided for the variable aircraft identification to be inserted by the pilot while on the ground, or during flight. The means for modifying and displaying aircraft identification shall be a simple crew action independent of the entry of other flight data.</p>	<p>e. Aircraft Identification Data</p> <p>If the aircraft uses a flight number for aircraft identification, a means SHALL be provided for the variable aircraft identification to be inserted by the pilot while on the ground. <u>A means may be provided for modifying aircraft identification in flight.</u></p>

Table 14 — DO-181E Section 2.2.13.1.2.e amendment

A1.2.3.7 Interrogation Acceptance Protocol Changes (All-Call reply capability)

A1.2.3.7.1 The transponder All-Call interrogation reply acceptance requirements are reduced to reply only to ATCRBS Mode C (P1-P3) interrogations. The purpose is to reduce the reply rate of TABS while maintaining TCAS and TAS interoperability. The requirements of this ETSO are identical to RTCA document DO-181E except for the changes shown below.

A1.2.3.7.2 RTCA document DO-181E, Section 2.2.18.2.2.b, Interrogation Acceptance Protocol (Figure 2-12), is amended as shown in Table 15.

DO-181E text	Modified text for this ETSO
<p>All-Call Address – If the address extracted from the received interrogation consists of 24 ONEs and UF=11, the transmission is a Mode S-Only All-Call and the received interrogation shall be accepted according to “i” below unless the lockout protocol is in effect.</p>	<p>All-Call Address – If the address extracted from the received interrogation consists of 24 ONEs and UF=11, the transmission is a Mode S-Only All-Call and the received interrogation SHALL not be accepted.</p>

~~Mode S Only All-Call shall not be accepted (no replies) when in the on-the-ground state (consistent with the CA, VS and FS fields)~~

Table 15 — DO-181E Section 2.2.18.2.2.b amendment

A1.2.3.7.3 RTCA document DO-181E, Section 2.2.18.2.2.c, Interrogation Acceptance Protocol (Figure 2-12), is amended as shown in Table 16.

DO-181E text	Modified text for this ETSO
ATCRBS/Mode S All-Call – An ATCRBS/Mode S All-Call interrogation (1.6 microseconds P4) shall be accepted unless the TD timer is running or side-lobe suppression is in effect or when in the “on-the-ground” state (consistent with the CA, VS and FS fields).	ATCRBS/Mode S All-Call – An ATCRBS/Mode S All-Call interrogation (1.6 microseconds P4) SHALL not be accepted.

Table 16 — DO-181E Section 2.2.18.2.c amendment

A1.2.3.8 RTCA document DO-181E, Section 2.2.18.2.2.g, Interrogation Acceptance Protocol, paragraph g, All-Call Lockout Conditions, is amended as shown in Table 17.

DO-181E text	Modified text for this ETSO
All-Call Lockout Conditions – On receipt of a Mode S-Only All-Call (UF=11) containing an Interrogator Code (IC and CL fields) corresponding to the designator of a running TL timer, the interrogation shall not be accepted. unless the contained PR code is 8 through 12 and the “on-the-ground” report (CA, VS or FS field) does not include the ground condition. Upon receipt of a Mode S-Only All-Call (UF=11) containing II=0, the interrogation shall be accepted if the TD timer is not running or if the received PR code is 8 through 12 and the “on-the-ground” report (CA, VS or FS field) does not include the ground condition.	All-Call Lockout Conditions – On receipt of a Mode S-Only All-Call (UF=11) the interrogation SHALL not be accepted.

Table 17 — DO-181E Section 2.2.18.2.g amendment

A1.2.3.9 RTCA document DO-181E, Section 2.2.18.2.2.i, Interrogation Acceptance Protocol Stochastic All-Calls, should not be implemented in Class A TABS.

A1.2.3.10 Two new sections are added here to explicitly define interrogation acceptance criteria for TABS.

A1.2.3.10.1 RTCA document DO-181E, Section 2.2.18.2.2.L, Interrogation Acceptance Protocol (Figure 2-12), is added as shown in Table 18.

DO-181E text	Modified text for this ETSO
None	ATCRBS Mode A Rejection – ATCRBS Mode A interrogations (P1-P3 spacing 8 microseconds) SHALL not be accepted. Recovery from a Mode A interrogation shall adhere to the requirements of Section 2.2.7.2 defined for recovery from a desensitizing pulse.

Table 18 — DO-181E Section 2.2.18.2.2L addition

A1.2.3.10.2 RTCA document DO-181E, Section 2.2.18.2.2.m, Interrogation Acceptance Protocol (Figure 2-12), is added to as shown in Table 19. This change reduces the range at which addressed Mode S ground interrogations would be replied to. The intent is to reduce the reply rate of the TABS. Sensitivity to TCAS interrogations is not affected.

DO-181E text	Modified text for this ETSO
None	Ground-to-Air Mode S Acceptance – Mode S interrogations, excluding UF=0 SHALL be accepted at the Mode S MTL (paragraph 2.2.2.4 b) +3dB ± 1dB.

Table 19 — DO-181E Section 2.2.18.2.2.m addition

A1.2.3.11 RTCA document DO-181E, Section 2.2.18.2.3, Interrogation Reply Coordination, is amended as shown in Table 20.

DO-181E text		Modified text for this ETSO	
The transponder SHALL generate replies as follows, except when in the on-the-ground state:		The transponder SHALL generate replies as follows, except when in the on-the-ground state:	
Interrogations	Replies	Interrogations	Replies
ATCRBS Mode A	4096 Codes	ATCRBS Mode A	SHALL not reply
ATCRBS Mode C	Altitude Codes	ATCRBS Mode C	Altitude Codes
ATCRBS Mode A/Mode S All-Call	Reply is DF=11	ATCRBS Mode A/Mode S All-Call	SHALL not Reply
ATCRBS Mode C/Mode S All-Call	Reply is DF=11	ATCRBS Mode C/Mode S All-Call	SHALL not Reply
Mode S-only All-Call (UF=11)	Reply is DF=11	Mode S-only All-Call (UF=11)	SHALL not Reply

Table 20 — DO-181E Section 2.2.18.2.3 amendment

A1.2.3.12 RTCA document DO-181E, Section 2.2.18.2.4, Lockout Protocol, should not be implemented in Class A TABS.

A1.2.3.13 RTCA document DO-181E, Section 2.2.18.2.5, Multisite Lockout Protocol, should not be implemented in Class A TABS.

A1.2.3.14 RTCA document DO-181E, Section 2.2.18.2.7, Flight Status and Vertical Status Protocols, is amended as shown in Table 21.

DO-181E text	Modified text for this ETSO
Mode S-equipped aircraft Shall report details of their flight status. The source of and the rules for such reports are as follows: a. Alert – The transponder Shall transmit the 4096 identification code in ATCRBS Mode A replies and in the ID field of downlink format DF=5. This code can be changed by the pilot, and when a change is made an alert condition Shall be established. If the identification code is changed to 7500, 7600 or 7700, the alert condition Shall be permanent. If the identification code is changed to any other value, the alert condition Shall be temporary and self-cancelling after 18 ± 1 seconds (TC timer). The TC timer Shall be retriggered and continued for 18 ± 1 seconds after any	Mode S-equipped aircraft SHALL report details of their flight status. The source of and the rules for such reports are as follows: a. Alert – The transponder SHALL transmit the 4096 identification code in the ID field of downlink format DF=5. When a change is made an alert condition SHALL be established. If the identification code is changed to 7500, 7600 or 7700, the alert condition SHALL be permanent. If the identification code is changed to any other value, the alert condition SHALL be temporary and self-cancelling after 18 ± 1 seconds (TC timer). The TC timer SHALL be retriggered and continued for 18 ± 1 seconds after any change has been accepted by the transponder function. The alert

change has been accepted by the transponder function. The alert condition Shall be reported in the FS field. The permanent alert condition Shall be terminated and replaced by a temporary alert condition when the identification code is set to a value other than 7500, 7600 or 7700.	condition SHALL be reported in the FS field. The permanent alert condition SHALL be terminated and replaced by a temporary alert condition when the identification code is set to a value other than 7500, 7600 or 7700.
--	--

Table 21 — DO-181E Section 2.2.18.2.7 amendment

A1.2.3.15 RTCA document DO-181E, Section 2.2.18.2.9, All-Call Reply Protocol, should not be implemented in Class A TABS.

A1.2.3.16 RTCA document DO-181E, Section 2.2.19.1, Minimum Level 2 Transponder Requirements, is amended as shown in Table 22.

DO-181E text	Modified text for this ETSO
<p>The operational functions described in §1.4.3.2 require that this transponder Shall, in addition to the functions of the Level 1 transponder:</p> <p>a. Process uplink and downlink formats DF=16, UF=DF=20 and 21 (Figure 2-14). The format UF=16 is optional.</p> <p>Note: UF=16 is supported by transponders connected to an on-board operational TCAS (see §2.2.22).</p> <p>b. Receive broadcast transmissions from sensors (§2.2.19.1.11).</p> <p>c. Follow the protocols for:</p> <p>Comm-A (see §2.2.19.1.10).</p> <p>Comm-B (see §2.2.19.1.12).</p> <p>Comm U/V (air-air) (see §2.2.19.1.16).</p> <p>Multisite message operation (see §2.2.19.2).</p> <p>Report Codes 4 through 7 in the CA field (see §2.2.14.4.6).</p> <p>TCAS crosslink capability (see §2.2.19.1.18).</p>	<p>The operational functions described in paragraph 1.4.3.2 require that this transponder SHALL, in addition to the functions of the Level 1 transponder:</p> <p>a. Process uplink and downlink formats DF=16, UF=DF=20 and 21 (Figure 2-14).</p> <p>The format UF=16 <u>SHALL not be accepted. TABS SHALL not be installed with an on-board TCAS system.</u></p> <p>b. <u>Requirement Deleted.</u></p> <p>c. Follow the protocols for:</p> <p>Comm-B (see paragraph 2.2.19.1.12.1 through 2.2.19.1.12.3).</p> <p>Report Codes 4 through 7 in the CA field (see paragraph 2.2.14.4.6).</p> <p>TCAS crosslink capability (see paragraph 2.2.19.1.18).</p>

Table 22 — DO-181E Section 2.2.19.1 amendment

A1.2.3.17 RTCA document DO-181E, Section 2.2.19.1.3, Information Transfer, should not be implemented in Class A TABS.

A1.2.3.18 RTCA document DO-181E, Section 2.2.19.1.4, Interrogation-Reply Coordination, is amended per Table 23. Equipment using Minimum Level 2 Transponder Requirements, SHALL follow the text in DO-181E as written.

DO-181E text		Modified text for this ETSO	
The transponder SHALL generate replies to interrogations as follows:		The transponder SHALL generate replies to interrogations as follows:	
Interrogation	Reply	Interrogation	Reply
ATCRBS Mode A (see Note)	4096 code	ATCRBS Mode A (see Note)	<u>SHALL not reply</u>

ATCRBS Mode C (see Note)	Altitude Code	ATCRBS Mode C (see Note)	Altitude Code
ATCRBS/Mode S All-Calls (see Note)	DF=11	ATCRBS/Mode S All-Calls (see Note)	SHALL not reply
UF=4 and UF=5	as below	UF=4 and UF=5	as below
UF=11 (see Note)	DF=11	UF=11 (see Note)	SHALL not reply
UF=20 and UF=21	as below	UF=20 and UF=21	as below
Broadcast	None	Broadcast	None

Table 23 — DO-181E Section 2.2.19.1.4 amendment

A1.2.3.19 The Lockout Protocol described in RTCA document DO-181E, Section 2.2.19.1.5, should not be implemented in Class A TABS.

A1.2.3.20 The UM Protocol described in RTCA document DO-181E, Section 2.2.19.1.9, should not be implemented in Class A TABS.

A1.2.3.21 The Comm-A Protocol described in RTCA document DO-181E, Section 2.2.19.1.10, should not be implemented in Class A TABS.

A1.2.3.22 The Broadcast Protocol described in RTCA document DO-181E, Section 2.2.19.1.11, should not be implemented in Class A TABS.

A1.2.3.23 The Air-Initiated Comm-B Protocol described in RTCA document DO-181E, Section 2.2.19.1.12.4, should not be implemented in Class A TABS.

A1.2.3.24 The Comm-B Broadcast Protocol described in RTCA document DO-181E, Section 2.2.19.1.12.5, should not be implemented in Class A TABS.

A1.2.3.25 The Updating the Data Link Capability Report described in RTCA document DO-181E, Section 2.2.19.1.12.6.3, should not be implemented in Class A TABS.

A1.2.3.26 The Change of Aircraft Identification described in RTCA document DO-181E, Section 2.2.19.1.13.e, should not be implemented in Class A TABS.

A1.2.3.27 Linked Comm-A Coding described in RTCA document DO-181E, Section 2.2.19.1.14, should not be implemented in Class A TABS.

A1.2.3.28 The Comm-U/V Protocol described in RTCA document DO-181E, Section 2.2.19.1.16, should not be implemented in Class A TABS.

A1.2.3.29 The Data Handling Interfaces described in RTCA document DO-181E, Section 2.2.19.1.17, should not be implemented in Class A TABS.

A1.2.3.30 The Multisite Message Protocol described in RTCA document DO-181E, Section 2.2.19.2, should not be implemented in Class A TABS.

A1.2.3.31 Surveillance Identifier (SI) requirements contained in RTCA document DO-181E, Section 2.2.24.2, should not be implemented in Class A TABS.

A1.2.3.32 The Elementary Surveillance (ELS) Compliant Transponder requirements in RTCA document DO-181E, Section 2.2.24, do not apply to TABS equipment. TABS SHALL not claim ELS compliance. Changes made to ELS registers do not need to be indicated via a Comm-B broadcast. If one or more of the ELS registers are supported, then Section 2.2.24 requirements SHALL apply except Sections 2.2.24 b 4, 2.2.24 c, 2.2.24.2, 2.2.24.3.2.5, and 2.2.24.3.4, which do not apply.

A1.2.3.33 The Enhanced Surveillance (EHS) Compliant Transponders requirements in RTCA/DO-181E, Section 2.2.25, do not apply to TABS. TABS equipment SHALL not claim EHS compliance. Changes made

to EHS registers do not need to be indicated via a Comm-B broadcast. If one or more of the EHS registers are supported, then Section 2.2.25 requirements SHALL apply except Sections 2.2.25.1.2.4 and 2.2.25.2.3, which do not apply. Also, Section 2.2.25, paragraph 6 ‘Transponder capable of supporting EHS...’, must support ELS per A1.2.3.32 of this ETSO.

A1.2.4 Altitude Source Function Requirements (For Class A Devices)

A1.2.4.1 The altitude source function shall meet the performance requirements of ETSO-C88b, Automatic Pressure Altitude Reporting Code-Generating Equipment, dated 5 August 2016. It is recommended that the altitude source provide 25 ft or better resolution.

A1.2.5 ADS-B OUT Function Requirements Derived From EUROCAE ED-102A, including Corrigendum-1, (For Class A Devices)

A1.2.5.1 The ADS-B OUT function must be 1090 Extended Squitter (ES) OUT, to support TCAS surveillance. The 1090ES OUT function must meet the Minimum Performance Standards (MPS) qualification and documentation requirements in EUROCAE ED-102A, MOPS for 1090 MHz Extended Squitter Automatic Dependent Surveillance – Broadcast (ADS-B) and Traffic Information Services – Broadcast (TIS-B), dated December, 2009, including Corrigendum-1, Section 2, dated January, 2012, for a Class B0 ADS-B OUT transmitter with the following modifications.

A1.2.5.2 EUROCAE ED-102A, including Corrigendum-1, Section 2, dated January, 2012, Paragraph 2.2.2.1.c, Mode S Transponder Based Transmitters, is amended as shown in Table 24.

ED-102A text	Modified text for this ETSO
If the ADS-B transmitter is based on Mode S transponders, then for transponder functions it shall comply with RTCA/DO-181D (EUROCAE ED-73C) for each class of transponder specified in the latest version of FAA TSO C112 (ETSO 2C112)	If the ADS-B transmitter is based on Mode S transponders, then for The transponder functions SHALL comply with RTCA/DO-181 <u>E</u> (EUROCAE ED-73 <u>E</u>) for each class of transponder specified in the latest version of ETSO-C112 (FAA TSO C112), except where modified by Appendix 1 to this ETSO.

Table 24 — ED-102A Section 2.2.2.1.c amendment

A1.2.5.3 The output power SHALL be as specified in EUROCAE ED-102A, including Corrigendum-1, dated January, 2012, Section 2.2.2.2.10.1.a., for Class A0 and B0 equipment. The RF Peak Output power SHALL be at least 18.5 dBW (70 watts).

A1.2.5.4 Broadcast of the ADS-B Surface Position Messages defined in EUROCAE ED-102A including Corrigendum-1, Section 2.2.3.2.4, is optional.

A1.2.5.5 EUROCAE ED-102A including Corrigendum-1, Section 2.2.3.2.7.2, Aircraft Operational Status Messages, is amended as shown in Table 25.

ED-102A text	Modified text for this ETSO
The ‘Aircraft Operational Status Message’ is used to provide the current status of the aircraft. The format of the Aircraft Operational Status Message shall be as specified in Figure 2-11, while further definition of each of the subfields is provided in the subsequent paragraphs.	The ‘Aircraft Operational Status Message’ is used to provide the current status of the aircraft. The format of the Aircraft Operational Status Message shall be as specified in Figure 2-11, while further definition of each of the subfields is provided in the subsequent paragraphs. Broadcast of Aircraft Operational Status Message subtype=1, Surface Messages, is optional.

Table 25 — Aircraft Operational Status Message

A1.2.5.6 When TABS is installed with a position source meeting the Class B requirements of this ETSO and transmitting a valid position, the transmitted NIC SHALL be set to 6 (0.5 NM), reference EUROCAE

ED-102A including Corrigendum-1, dated January 2012, Section 2.2.8.1.16. The transmitted SIL SHALL be set to 1 (1×1E-3/ h), reference EUROCAE ED-102A including Corrigendum-1, dated January 2012, Section 2.2.5.1.40. When TABS is installed with a position source compliant with ETSO-C145, ETSO-C146 or ETSO-C196, NIC and SIL SHALL be set in accordance with EUROCAE ED-102A including Corrigendum-1, dated January, 2012. When the position is not valid, NIC and SIL SHALL be set to 0 (zero).

A1.2.5.7 The System Design Assurance (SDA), SHALL be set to 1, reference EUROCAE ED-102A, including Corrigendum-1, dated January 2012, Section 2.2.5.1.50. The probability of an undetected fault causing transmission of false or misleading information SHALL be less than or equal to 1E-3.

A1.2.5.8 Navigation Accuracy Category for Position, (NACp) SHALL be derived from the Horizontal Figure of Merit (HFOM) in accordance with EUROCAE ED-102A, including Corrigendum-1, dated January 2012, Section A.1.4.9.9; however, TABS Class B position sources may not provide HFOM directly. When HFOM is not available directly, HFOM SHALL be derived from Horizontal Dilution of Precision (HDOP) according to the following formula: $HFOM = 2 * HDOP * User\ Equivalent\ Range\ Error\ (UERE)$, where the UERE is 6 metres. This UERE is based on typical single frequency (L1) receiver performance and an assumption of mid-latitude atmospheric propagation. Although the real-time UERE may fluctuate, this assumption is sufficient to support the TABS use case. (Ref. Global Positioning System Signals, Measurements and Performance, by Pratap Misra and Per Enge, copyright 2001).

A1.2.5.9 When a TABS is installed with a position source meeting the Class B requirements of this ETSO and transmitting a valid position, the transmitted Navigation Accuracy Category for Velocity, (NACv) SHALL be set to 1 (10 m/s), reference EUROCAE ED-102A including Corrigendum-1, dated January, 2012, Section 2.2.5.1.19. When position is not valid, NACv SHALL be set to 0 (zero).

A1.2.5.10 Geometric Vertical Accuracy (GVA) SHALL be derived from Vertical Figure of Merit, (VFOM) in accordance with EUROCAE ED-102A including Corrigendum-1, dated January, 2012, Section 2.2.3.2.7.2.8. Class B position sources may not provide VFOM directly. When VFOM is not available directly, VFOM SHALL be derived from Vertical Dilution of Precision (VDOP) according to the following formula: $VFOM = 2 * VDOP * UERE$, where the UERE is 6 metres.

A1.2.5.11 The Type Code 31, Operational Status Message, subfield ‘Airborne Capability Class Code’, SHALL be changed to indicate the device is a TABS.

A1.2.5.11.1 The Operational Status Message SHALL be modified to indicate that it meets the performance standards of this ETSO. ED-102A, including Corrigendum-1, dated January, 2012, paragraph 2.2.18.4.7 and Figure 2-40, is modified by this ETSO. Message bits 53-54, (ME Bits 21-22), SHALL describe the capabilities of the TABS per Table 26. Set bit 54 to 1 (one) to indicate that either TABS Class A, Class B, or both classes of equipment are installed.

Bit 53	Bit 54	Description
0	0	Not TABS equipped
0	1	TABS Equipped
1	0	TABS device (reserved for future use)
1	1	TABS device (reserved for future use)

Table 26 — ED-102A Airborne Capability Class Message format

A1.2.6 GNSS Position Source Function Requirements (For Class B Devices)

A1.2.6.1 Manufacturers may use commercial off-the-shelf (COTS) GNSS position sources to meet the performance of this ETSO as long as the sensor meets the requirements in this section. The position source shall be capable of using satellite-based augmentation system (SBAS) corrections and health messages to exclude satellites from the position solution or to correct satellite range errors. In areas

where the SBAS is available, the TABS shall use the SBAS corrections and health messages to exclude satellites from the position solution or to correct satellite range errors. In areas where the SBAS is not available or out of service, the TABS may continue to operate. The regional airspace authority will determine what operational impacts this may have on air-to-ground usage of TABS equipment. According to the FAA the GPS constellation experiences a significant ramp error approximately once a year. During these events, a chipset which uses the SBAS will, depending on the received SBAS messages, either correct or exclude the faulty satellite. Refer to RTCA document DO-229E, Minimum Operational Performance Standards for Global Positioning System/Satellite-Based Augmentation System Airborne Equipment, when interpreting SBAS-related requirements.

A1.2.6.2 The GNSS position source SHALL provide a GPS-only solution for use by the TABS ADS-B function. The FAA and EASA have not evaluated the performance of other GNSS systems for use in support of aviation-intended functions. This ETSO will be updated once sufficient analysis has been performed to show that other GNSS are appropriate for use by TABS equipment. Note, the GPS-only solution refers to the use of the GPS satellite constellation, it does not exclude augmentation of the GPS solution, such as provided by SBAS or GBAS systems.

A1.2.6.3 The GNSS horizontal position error SHALL not exceed 30 metres, 95th percentile, when the Horizontal Dilution of Precision (HDOP) is 2.5 or less. The GNSS position source SHALL either transmit a Horizontal Figure of Merit (95 %) (HFOM) or an HDOP metric.

Note: The 30-metre horizontal position fixing error requirement assumes a UERE of 6 metres, consistent with Section A1.2.5.8.

A1.2.6.4 Removed.

A1.2.6.5 The GNSS position source SHALL be capable of transmitting horizontal velocity measurements more accurate than 10 m/s, 95th percentile.

A1.2.6.6 The GNSS position source SHALL not transmit false or misleading data in the presence of broadband interference. There is no minimum interference rejection requirement for TABS equipment and loss of position in the presence of interference is acceptable behaviour.

A1.2.6.7 The GNSS position source SHALL not use SBAS corrections when the SBAS satellite is broadcasting message type 0.

A1.2.6.8 The GNSS position source SHALL exclude satellites with UDREI=15 reported in the SBAS fast corrections.

A1.2.6.9 The GNSS position source SHALL apply SBAS fast and long-term corrections when available.

A1.2.6.10 The GNSS position source SHALL be capable of transmitting geometric altitude, Height Above the Ellipsoid (HAE) measurements more accurate than 45 metres, 95th percentile, when the Vertical Dilution of Precision (VDOP) is 3.7 or less. The GNSS position source SHALL either transmit a Vertical Figure of Merit (95 %) (VFOM) or a Vertical Dilution of Precision (VDOP) metric.

Note: The 45-metre vertical position fixing error requirement assumes a UERE of 6 metres, consistent with Section A1.2.5.10.

A1.2.7 Antenna Function Requirements

A1.2.7.1 The requirements for transponder antennas are specified in ETSO-C112e. The requirements for GNSS antennas are specified in ETSO-C190 and ETSO-C144a. The antennas should be designed to meet the performance specified in the applicable ETSO. However, the TABS may benefit significantly in installation costs from implementations where the antennas are integrated in the TABS equipment. Small degradations in antenna performance may be acceptable as a trade-off for installation cost.

A1.2.7.2 Antennas may be installed internally on aircraft that are transparent to radio frequencies. An internal antenna may not be appropriate on aircraft with a metal hull. If an antenna is installed internally, testing will need to be conducted to ensure the TABS is not negatively impacted and installation guidance must accompany the unit to ensure the system is properly fitted to the aircraft.

A1.2.7.3 Because TABS may be installed on a radio frequency (RF) transparent fuselage near a pilot or passenger, or in a cockpit in close proximity to a pilot or passenger, consideration must be given to antenna placement to ensure it does not pose a hazard to humans or combustible materials. Manufacturers must provide installation guidance describing the minimum safe distance the antenna can be to the nearest human body or if applicable, combustible material. Appendix 3 to this ETSO provides a more in-depth discussion of this subject based on FCC and European documents.

A1.2.8 Form factor and power

A1.2.8.1 An ideal implementation of the TABS would be a single integrated unit with minimal connections to the airframe, such as; mechanical mounting, power, and static air source. Where the equipment might be shared between multiple airframes, the mechanical mounting could incorporate an airframe-specific configuration module (containing such items as the ICAO 24-bit aircraft address), and be designed such that no tools are required to remove or install the TABS.

A1.2.8.2 Low-power consumption design is important. Designs specifically intended for long-term battery operation are ideal. If the TABS is battery powered, it should be designed to provide system integrity commensurate with the failure condition category / classification stated in paragraph 3.2.1.

[Amdt. ETSO/13]

[Amdt. ETSO/16]

Appendix 2 to ETSO C-199 A1 – Test Requirements

ED Decision 2020/011/R

A2 Testing Introduction

A2.1 Testing Intent

A2.1.1 This Appendix provides an acceptable means to verify the major functions of the TABS.

A2.1.2 The TABS is not intended to accept and reply to any UF=11 All-Call interrogations. RTCA document DO-181E tests like 2.4.2.1 Step 6 that use the Mode S Only All-Call interrogation (UF=11) will need to use a different interrogation, such as a UF=0 interrogation.

A2.2 Testing Requirements

A2.2.1 The tests defined here are derived from tests in the reference documents or written here to ensure compliance with the intended capabilities of TABS equipment. These tests are one acceptable means to demonstrate that the equipment meets the functional requirements defined in Appendix 1 to this ETSO. Functionality not modified by Appendix 1 should be verified by the test outlined in the applicable standards, e.g. RTCA document DO-181E.

A2.2.2 Table 27 provides notes in italics and parenthesis explaining how to read the tables that modify the text in the source documents.

(Source document reference)	Modified text for this ETSO
(This is a copy of the original text from the source document. Material to be deleted from this original text is marked with strikethrough formatting .)	(This is the requirement for this ETSO. Modifications to the source text are marked in <u>bold and underlined</u> to assist in identifying changes).

Table 27 — (Source document reference) (type of change)

A2.2.3 Testing Transponder Function Requirements Derived From DO-181E (For Class A Devices)

A2.2.3.1 Testing of the transponder function of the TABS should follow the tests outlined in document RTCA document DO-181E, Minimum Operational Performance Standards for Air Traffic Control Radar Beacon System/Mode Select (ATCRBS/Mode S) Airborne Equipment, dated 17 March 2011, Section 2.3, 2.4, and 2.5, with the following exceptions:

A2.2.3.1.1 Testing of Flight Crew Control Functions

A2.2.3.1.2 Testing should verify that the requirements of RTCA document DO-181E, as modified by paragraph A1.2.3.1.2 of this ETSO, have been properly incorporated.

A2.2.3.1.3 Testing should verify that changes made to paragraph 2.1.7 a, in RTCA document DO-181E, per Section A1.2.3.1.3, have been properly incorporated.

A2.2.3.1.3.1 Testing should verify the requirements of A1.2.3.1.3, by performing the test outlined in RTCA document DO-181E Section 2.5.4.11. Test results should verify that the 4096 code can be set while on the ground. If the 4096 code can be set in flight, testing should verify that the 4096 code can be set while in the air (weight-off-wheels condition) per RTCA/DO-181E Section 2.5.4.11.

A2.2.3.1.3.2 Testing should verify the requirements of A1.2.3.1.3, by performing the test outlined in RTCA/DO-181E Section 2.5.4.11. Testing should verify that a means of selecting and transmitting Mode 3/A code 7700 (emergency) is provided and tested per RTCA document DO-181E Section 2.5.4.11.

A2.2.3.1.3.3 Testing should verify the requirements of A1.2.3.1.3, by performing the test outlined in RTCA document DO-181E Section 2.5.4.11. Testing should also verify that a means of selecting and

transmitting an alternate Mode 3/A codes is provided and tested per RTCA document DO-181E Section 2.5.4.11.

A2.2.3.1.4 Testing should verify the requirements of A1.2.3.1.4, by performing the test outlined in RTCA document DO-181E Section 2.5.4.3.b. Test results should verify aircraft without a means of determining air/ground state, report in the air at all times. Aircraft with an automatic means to determine the air/ground state, must verify that the air/ground state is set properly. Perform the test outlined in RTCA document DO-181E Section 2.5.4.3.b. If capable of determining the air/ground state, test results should verify that the aircraft reports in the air when in the air, and on the ground when on the ground.

A2.2.3.1.5 Testing should verify that the requirements of A1.2.3.1.5, have been properly incorporated. If a means of selecting the standby condition is provided, testing should verify return to normal operation from standby condition is within 5 seconds.

A2.2.3.1.6 Testing should verify that the requirements of A1.2.3.1.6, have been properly incorporated. If a means of initiating the IDENT (SPI) feature is installed, testing shall verify it functions properly per RTCA document DO-181E Section 2.5.4.3. (see Also A1.2.3.5 and A2.2.3.5).

A2.2.3.2 Testing Reply Rate Capability Changes

A2.2.3.2.1 This section provides test criteria for the reply rate changes based on assumptions made in Section A1.2.3.2.1.

A2.2.3.2.2 Testing should verify that changes made to A1.2.3.2.2 have been correctly incorporated into TABS equipment.

A2.2.3.2.2.1 Testing should verify that the requirements of A1.2.3.2.2.1 of this ETSO have been satisfied. Testing outlined in RTCA document DO-181E, Section 2.3.2.2.3 step 1, should verify that the transponder be able to continuously generate at least 100 ATCRBS 15-pulse replies per second.

A2.2.3.2.2.2 Testing should that verify the requirements of A1.2.3.2.2.2 of this ETSO have been satisfied. Testing outlined in RTCA document DO-181E, Section 2.3.2.2.3 step 3, should verify that the transponder is capable of a peak reply rate of 150 ATCRBS 15-pulse replies per second for a duration of 100 milliseconds.

A2.2.3.2.2.3 Testing should verify that the changes made to RTCA document DO-181E Section 2.2.3.4.2.a have been correctly incorporated into TABS equipment per A1.2.3.2.2.3.

A2.2.3.2.2.3.1 Testing should verify that the requirements of RTCA document DO-181E, Section 2.2.3.4.2.a, as modified by paragraph A1.2.3.2.2.3 of this ETSO have been satisfied. Testing outlined in RTCA document DO-181E, Section 2.3.2.2.3 step 2, should verify that the transponder provides at least 29 short Mode S replies in any 1-second interval.

A2.2.3.2.2.3.2 Testing should verify that the requirements of RTCA document DO-181E, Section 2.2.3.4.2.a, as modified by paragraph A1.2.3.2.2.3 of this ETSO have been satisfied. Testing outlined in RTCA document DO-181E, Section 2.3.2.2.3 step 3, should verify that the transponder provides at least 10 short Mode S replies in a 100-millisecond interval.

A2.2.3.2.2.3.3 Testing should verify that the requirements of RTCA document DO-181E, Section 2.2.3.4.2.a, as modified by paragraph A1.2.3.2.2.3 of this ETSO have been satisfied. Testing outlined in RTCA document DO-181E, Section 2.3.2.2.3 step 4, should verify that the transponder provides at least 5 short Mode S replies in a 25-millisecond interval.

A2.2.3.2.2.3.4 Testing should verify that the requirements of RTCA document DO-181E, Section 2.2.3.4.2.a, as modified by paragraph A1.2.3.2.2.3 of this ETSO have been satisfied. Testing outlined in RTCA document DO-181E, Section 2.3.2.2.3 step 5, should verify that the transponder provides at least 3 short Mode S replies in a 1.6-millisecond interval.

A2.2.3.2.2.4 Testing should verify that the changes made to RTCA document DO-181E, Section 2.2.3.4.2.b, have been correctly incorporated into TABS equipment per A1.2.3.2.2.4.

A2.2.3.2.2.4.1 Testing should verify that the requirements of RTCA/DO-181E, Section 2.2.3.2.4.2.b, as modified by paragraph A1.2.3.2.2.4 of this ETSO have been satisfied. Testing outlined in RTCA document DO-181E, Section 2.3.2.2.3 step 2, should verify that the transponder provides at least 10 of the 29 Mode S replies as long-format replies in any 1-second interval.

A2.2.3.2.2.4.2 Testing should verify that the requirements of RTCA document DO-181E, Section 2.2.3.2.4.2.b, as modified by paragraph A1.2.3.2.2.4 of this ETSO have been satisfied. Testing outlined in RTCA document DO-181E, Section 2.3.2.2.3 step 3, should verify that the transponder provides at least 4 of the 10 Mode S replies as long-format replies in a 100-millisecond interval.

A2.2.3.2.2.4.3 Testing should verify that the requirements of RTCA document DO-181E, Section 2.2.3.2.4.2.b, as modified by paragraph A1.2.3.2.2.4 of this ETSO have been satisfied. Testing outlined in RTCA document DO-181E, Section 2.3.2.2.3 step 4, should verify that the transponder provides at least 3 of the 5 Mode S replies as long-format replies in a 25-millisecond interval.

A2.2.3.2.2.4.4 Testing should verify that the requirements of RTCA document DO-181E, Section 2.2.3.2.4.2.b, as modified by paragraph A1.2.3.2.2.4 of this ETSO have been satisfied. Testing outlined in RTCA document DO-181E, Section 2.3.2.2.3 step 5, should verify that the transponder provides at least 2 of the 4 Mode S replies as long-format replies in a 1.6-millisecond interval.

A2.2.3.3 Testing Reply Rate Limiting Changes

A2.2.3.3.1 Testing should verify that the requirements of RTCA document DO-181E, Section 2.2.7.3.1, as modified by paragraph A1.2.3.3.1 of this ETSO have been satisfied. Testing outlined in RTCA document DO-181E, Section 2.4.2.2.5 step 1, should be performed to verify that the unit does not reply to Mode A interrogations.

A2.2.3.3.2 Testing should verify that the requirements of RTCA document DO-181E, Section 2.2.7.3.1, as modified by paragraph A1.2.3.3.2 of this ETSO have been satisfied. Testing outlined in RTCA document DO-181E, Section 2.4.2.2.5 step 1, should be performed to verify the unit is capable of between 100 continuous ATCRBS Mode C replies per second and the maximum continuous rate of which the transponder is capable, or 200 replies per second, whichever is less, without regard to the number of pulses in each reply. Sensitivity reduction SHALL apply only to the receipt of ATCRBS interrogations.

A2.2.3.4 Testing should verify that the requirements of RTCA document DO-181E, Section 2.2.13.1.2.c, as modified by paragraph A1.2.3.4 of this ETSO have been satisfied. Testing should show that airborne status is set to in the air unless the aircraft is air/ground determination capable. If the aircraft can determine air/ground state, testing should show that this capability is determined on the ground when on the ground and in the air when in the air.

A2.2.3.5 Testing should verify that the requirements of RTCA document DO-181E, Section 2.2.13.1.2.d, as modified by paragraph A1.2.3.5 of this ETSO have been satisfied. If the aircraft is capable of providing SPI, follow the test outlined in A2.2.3.1.6 of this ETSO to verify that it functions properly per RTCA document DO-181E Section 2.5.4.3 (see also, Section A1.2.3.1.6 and A2.2.3.1.6).

A2.2.3.6 Testing should verify that the requirements of RTCA document DO-181E, Section 2.2.13.1.2.e, as modified by paragraph A1.2.3.6 of this ETSO have been satisfied. Testing should show the aircraft ID loaded while on the ground is broadcast. If aircraft ID can be changed in flight, testing should verify that aircraft ID can be changed in flight and the new aircraft ID is broadcast.

A2.2.3.7 Testing of Interrogation Acceptance Protocol Changes (All-Call reply capability)

A2.2.3.7.1 Except where noted here, testing of the Interrogation Acceptance Protocol capability should follow that called out in RTCA document DO-181E. Testing of the Interrogation Acceptance Protocol capability should be modified from those called out in RTCA document DO-181E to meet the changes made in A1.2.3.7.1.

A2.2.3.7.2 Testing should verify that the requirements of RTCA document DO-181E, Section 2.2.18.2.2.b, as modified by paragraph A1.2.3.7.2 of this ETSO have been satisfied. Various tests in RTCA document DO-181E Section 2.4 utilise the Mode S Only All-Call interrogation and the expected reply to execute the test procedure. A discrete interrogation should be used as a substitute for these test procedures. Testing outlined in RTCA document DO-181E, Section 2.5.4.2, should verify that UF=11 interrogations are not accepted.

A2.2.3.7.3 Testing should verify that the requirements of RTCA document DO-181E, Section 2.2.18.2.2.c, as modified by paragraph A1.2.3.7.3 of this ETSO have been satisfied. Testing outlined in RTCA document DO-181E, Section 2.5.4.2, should verify that an ATCRBS/Mode S All-Call interrogation (1.6-microseconds P4) is not accepted. The pulse decoder tests in Section 2.4.2.5 for ATCRBS/Mode S All-Call interrogation acceptance shall be modified to verify that no ATCRBS/Mode S All-Call interrogations that meet the criteria for acceptance in RTCA document DO-181E, Section 2.2.6.2, produce a reply.

A2.2.3.8 Testing of the requirements of RTCA document DO-181E, Interrogation Acceptance Protocol, per Sections 2.5.4.4 and 2.5.4.5, are not required per A1.2.3.8 of this ETSO.

A2.2.3.9 Testing of the requirements of RTCA document DO-181E, Stochastic All-Calls, per 2.5.4.13, is not required per A1.2.3.9 of this ETSO.

A2.2.3.10 Testing should verify the modified Mode S MTL requirements added to RTCA document DO-181E, per Section A1.2.3.10. Test to ensure that paragraphs 2.2.18.2.2.L and 2.2.18.2.2.m have been properly incorporated.

A2.2.3.10.1 Testing outlined in RTCA document DO-181E, Section 2.4.2, should verify that ATCRBS Mode A interrogations (P1-P3 spacing 8 microseconds) are not accepted per A1.2.3.10.1. Various tests in RTCA document DO-181E, Section 2.4, utilise Mode A interrogations to execute the test procedure. Mode C interrogations should be used as a substitute for these test procedures. The pulse decoder tests in RTCA document DO-181E, Section 2.4.2.5, for Mode A interrogation acceptance shall be modified to verify that no Mode A interrogations that meet the criteria for acceptance in RTCA document DO-181E, Section 2.2.6.2, produce a reply. The requirement for recovery from a Mode A interrogation per A1.2.3.10.1 shall be tested according to RTCA document DO-181E, Section 2.4.2.6 step 1, except using a Mode A interrogation from the master and a Mode C interrogation from the slave.

A2.2.3.10.2 Testing should verify the requirements added to RTCA document DO-181E, paragraph 2.2.18.2.2.m, have been properly incorporated per Section A1.2.3.10.2. Verify the requirement added by this ETSO, by performing the test procedure in RTCA document DO-181E, Section 2.4.2.1 step 6, using a UF=0 to verify the Mode S MTL in Section 2.2.2.4.b and UF=4, 5, 20 and 21 to verify the modified MTL per A1.2.3.10.2.

A2.2.3.11 Testing should verify that the requirements of RTCA document DO-181E, Interrogation Reply Coordination, Section 2.2.18.2.3, as modified by A1.2.3.11 of this ETSO are satisfied. Testing outlined in RTCA document DO-181E, Section 2.5.4.2, shall be modified to verify that the unit does not reply to ATCRBS Mode A interrogations. Test ATCRBS Mode A/Mode S All-Calls, ATCRBS Mode C/Mode S All-Calls or UF=11 interrogations per testing outlined in A2.2.3.7 and A2.2.3.10.

A2.2.3.12 Testing of RTCA document DO-181E, Lockout Protocol, Section 2.2.18.2.4, is not required since TABS devices do not reply to All-Call interrogations per A1.2.3.12 of this ETSO. Testing using interrogations in RTCA document DO-181E, Section 2.5.4.4, should be performed to verify the unit properly replies to interrogations containing lockout commands from ground interrogations.

A2.2.3.13 Testing of RTCA document DO-181E, Multisite Lockout Protocol, Section 2.2.18.2.5, is not required since TABS devices do not reply to All-Call interrogations per A1.2.3.13 of this ETSO. Testing using interrogations in RTCA document DO-181E, Section 2.5.4.5, should be performed to verify that the unit properly replies to interrogations containing multisite lockout commands from ground interrogations.

A2.2.3.14 Testing should verify that the requirements of RTCA document DO-181E, Flight Status and Vertical Status Protocols, Section 2.2.18.2.7, as modified by A1.2.3.14 of this ETSO are satisfied. Testing outlined in RTCA document DO-181E Section 2.5.4.7 should be performed to verify that the unit sets the flight status bits properly consistently with the capabilities provided for Mode 3/A code entry per A1.2.3.1.3.

A2.2.3.15 Testing the requirement of RTCA document DO-181E, All-Call Reply Protocol, Section 2.2.18.2.9, as modified by A1.2.3.15 is not required. Testing outlined in RTCA document DO-181E, Section 2.5.4.8, does not need to be performed since the TABS does not support the All-Call Protocol.

A2.2.3.16 Testing should verify the Level 2 Transponder Requirements of RTCA document DO-181E, Minimum Level 2 Transponder Requirements, Section 2.2.19.1, as modified by A1.2.3.16 of this ETSO are satisfied. Testing outlined in RTCA document DO-181E Section 2.5.3 should be performed to verify that the unit performs per design specifications. Also, testing outlined in RTCA document DO-181E, Section 2.5.4.17, should be performed to verify that the unit does not process DF=16 messages.

A2.2.3.17 No test is required to verify the requirements of RTCA document DO-181E, Information Transfer, Section 2.2.19.1.3, per A1.2.3.17.

A2.2.3.18 Testing should verify that the requirements of RTCA document DO-181E, Interrogation-Reply Coordination, Section 2.2.19.1.4, as modified by A1.2.3.18 are met. Use tests in A2.2.3.7 and A2.2.3.10 in this ETSO to verify the TABS does not reply to ATCRBS Mode A, ATCRBS/Mode S All Calls and UF=11 interrogations.

A2.2.3.19 Testing of the requirements of RTCA document DO-181E, Lockout Protocol, Section 2.2.19.1.5, per Section 2.5.4.4, are not required per A1.2.3.19 of this ETSO. Testing should verify the TABS does not perform the UM Protocol per RTCA document DO-181E, Section 2.5.4.18.

A2.2.3.20 Since TABS do not support the Comm-B protocol except for GICB extraction requests, the requirements of RTCA/DO-181E, UM Protocol, Section 2.2.19.1.9, do not apply, per A1.2.3.20. Using a subset of the interrogations identified in RTCA document DO-181E, Section 2.5.4.18, select 12 interrogations with UF 4, 5, 20 and 21 and containing DI=0, 1 and 7 and verify that the reply contains UM field of 0 (zero).

A2.2.3.21 Testing of the requirements of RTCA document DO-181E, Comm-A Protocol, Section 2.2.19.1.10, per Section 2.5.4.15, is not required per A1.2.3.21 of this ETSO. Testing should verify that the TABS does not perform the Com-A Protocol per RTCA document DO-181E, Section 2.5.4.15.

A2.2.3.22 Testing of the requirements of RTCA document DO-181E, Broadcast Protocol, Section 2.2.19.1.11, as modified by A1.2.3.22 is not required since TABSs do not support this protocol.

A2.2.3.23 Testing of the requirements of RTCA document DO-181E, Air-Initiated Comm-B Protocol, Section 2.2.19.1.12.4, per Section 2.5.4.18, is not required per A1.2.3.23. To verify GICB extraction requirements, perform the portion of the test procedure of RTCA/DO-181E, Section 2.5.4.18 using interrogation patterns 1 to 24, to test the transponder in state 1 of the test matrix to verify proper reply content.

A2.2.3.24 Testing the requirements of RTCA document DO-181E, Comm-B Broadcast Protocol, Section 2.2.19.1.12.5, per 2.5.4.21 is not required per A1.2.3.24.

A2.2.3.25 Testing should verify the requirements of RTCA document DO-181E, Updating the Data Link Capability Report, Section 2.2.19.1.12.6.3, as modified by A1.2.3.25. Testing should verify that the TABS does not perform the Updating the Data Link Capability Report per RTCA document DO-181E, Section 2.5.4.33.

A2.2.3.26 Testing should verify the requirements of RTCA document DO-181E, Change of Aircraft Identification, Section 2.2.19.1.13.e, as modified by A1.2.3.26. Testing should verify that the TABS does not perform the Change of Identification per RTCA document DO-181E, Section 2.5.4.19.

A2.2.3.27 Testing the requirements of RTCA document DO-181E, Linked Comm-A Coding, Section 2.2.19.1.14, per 2.5.4.15, is not required per A1.2.3.27.

A2.2.3.28 Testing the requirements of RTCA document DO-181E, Comm-U/V Protocol, Section 2.2.19.1.16, per 2.5.4.17, as modified by A1.2.3.28 is not required.

A2.2.3.29 Testing the requirements of RTCA/DO-181E, Data Handling Interfaces, Section 2.2.19.1.17, per 2.5.4.20, as modified by A1.2.3.29 is not required.

A2.2.3.30 Testing the requirements of RTCA document DO-181E, Multisite Message Protocol, Section 2.2.19.2, per Section 2.5.4.5, as modified by A1.2.3.30 is not required.

A2.2.3.31 Testing the requirements of RTCA document DO-181E, Surveillance Identifier (SI), Section 2.2.24.2, per 2.6.2, as modified by A1.2.3.31 is not required.

A2.2.3.32 Testing the requirements of RTCA/DO-181E, Elementary Surveillance Capability, Section 2.2.24 as modified by A1.2.3.32, is not required. If one or more ELS registers are supported, test per RTCA/DO-181E, Section 2.6.

A2.2.3.33 Testing the requirements of RTCA document DO-181E, Enhanced Surveillance Capability, Section 2.2.25.3.2, as modified by A1.2.3.33 is not required. If the unit is Enhanced Surveillance Capability capable test per RTCA document DO-181E, Section 2.7.

A2.2.4 Testing Altitude Source Function Requirements

A2.2.4.1 Testing of the Altitude Source Function should follow that called out in ETSO-C88b, Automatic Pressure Altitude Reporting Code Generating Equipment, dated August 5, 2016.

A2.2.5 Testing ADS-B OUT Function Requirements (For Class A Devices)

A2.2.5.1 Testing should verify the ADS-B system performs its intended function per EUROCAE ED-102A, MOPS for 1090 MHz Extended Squitter Automatic Dependent Surveillance — Broadcast (ADS-B) and Traffic Information Services — Broadcast (TIS-B), dated December 2009, including Corrigendum 1, dated January 2012, except as modified by Section A1.2.5. Testing should follow the tests outlined in EUROCAE ED-102A, including Corrigendum 1, dated January 2012, Sections 2.3 and 2.4 with the following exceptions:

A2.2.5.2 Per Section A1.2.5.2, testing of transponder functions should follow the requirements in Sections A1.2.3 and A2.2.3 of this ETSO.

A2.2.5.3 Testing should verify the System RF Peak Power Output has a peak output level of at least 18.5 dBW (70 watts) per A1.2.5.3, reference EUROCAE ED-102A, including Corrigendum-1, dated January, 2012, RF Peak Power, Section 2.2.2.2.10.1.a. Testing outlined in ED-102A, Section 2.3.2.2.6.1 step 5, should verify that the unit under test provides a peak output power level of at least 18.5 dBW (70 watts).

A2.2.5.4 If the optional ADS-B Surface Position Messages function is provided, per Section, A1.2.5.4, testing should verify the ADS-B Surface Position Message is correctly populated and broadcast per EUROCAE ED-102A, Section 2.4.3.2.1.2.2.

A2.2.5.5 If the optional Typecode 31 subtype 1 Aircraft Operational Status Messages is provided per Section A1.2.5.5, testing should verify that the Aircraft Operational Status Messages is correctly populated and broadcast per EUROCAE ED-102A Section 2.4.3.2.7.2

A2.2.5.6 Per Section A1.2.5.6, testing should verify that NIC=6, and SIL=1 when using position from a Class B position source using test procedures in EUROCAE ED-102A, including Corrigendum 1, dated January 2012, Sections 2.4.8.1.5 and 2.4.5.1.40.

A2.2.5.7 Testing should verify that the System Design Assurance (SDA) is set to 1 to verify the requirement in Section A1.2.5.7, reference EUROCAE ED-102A, including Corrigendum 1, dated January 2012, System Design Assurance (SDA), Section 2.2.5.1.50.

A2.2.5.8 Per Section A1.2.5.8, testing should verify that Navigation Accuracy Category for Position (NACp) is set according to EUROCAE ED-102A including Corrigendum-1, dated January, 2012, Section 2.4.3.2.7.1.3.8. Testing should verify that the NACp is set appropriately when the position source is providing HDOP and not HFOM.

A2.2.5.9 If a TABS Class B position source is installed, verify that Navigation Accuracy Category Velocity (NACv) is set to 1 (10 m/s) per A1.2.5.9.

A2.2.5.10 Verify that Geometric Vertical Accuracy (GVA) is set per A1.2.5.10. Testing outlined in EUROCAE ED-102A, including Corrigendum 1, dated January, 2012, Section 2.4.3.2.7.2.8, should verify that GVA is set appropriately when the position source is providing VDOP and not VFOM.

A2.2.5.11 Verify Type Code 31, Airborne Capability Class Message, indicates that the unit under test is a TABS per A1.2.5.11.

A2.2.6 Testing of GNSS Position Source Function Requirements (For Class B Devices)

A2.2.6.1 A TABS incorporating a position source that is compliant with ETSO-C129, ETSO-C145, ETSO-C146 or ETSO-C196 must also meet the additional ADS-B criteria defined in AMC1 ACNS.D.ADSB.070 of CS-ACNS, to include any required testing. GNSS position sources that are not compliant with an existing GNSS ETSO will need to meet the requirements in paragraph A1.2.6 of this ETSO and verify it meets the minimum requirements by performing the tests outlined in Section A2.2.6 of this ETSO. The following tests were derived from a reduced set of requirements and associated tests found in RTCA document DO-229E.

A2.2.6.2 GPS Only Solution.

A2.2.6.2.1 Per paragraph A1.2.6.2, verify that the position source provides a GPS-SBAS or GPS Only solution for use by Class A TABS.

A2.2.6.3 Position Accuracy Tests.

A2.2.6.3.1 Two tests are used to verify the horizontal position accuracy to ensure the requirement in paragraph A1.2.6.3 is met. The first test is a 24-hour static scenario using live satellite signals. The second test uses a GNSS simulator to generate a scenario incorporating both static and dynamic aircraft manoeuvres.

A2.2.6.3.2 24-Hour Accuracy Test.

A2.2.6.3.2.1 The equipment SHALL be tested over a 24-hour period using live GPS satellite signals at a surveyed location. The equipment SHALL use an antenna representative of what will be used in an actual airborne installation. The horizontal position error SHALL be computed for each position estimate output by the equipment.

A2.2.6.3.2.2 Monitor the sensor-provided HFOM and VFOM, or HFOM and VFOM derived from the sensor-provided HDOP and VDOP per paragraphs A1.2.5.8 and A1.2.5.10. In order to pass the test, the horizontal position error must be less than 30 metres for at least 95 % of the samples and the horizontal accuracy reported must be greater than the actual position error for at least 95 % of the samples. In order to pass the test, the vertical position error must be less than 45 metres for at least 95 % of the samples and the vertical accuracy reported must be greater than the actual position error for at least 95 % of the samples.

A2.2.6.3.2.3 The horizontal position error SHALL not exceed 0.5 NM at any time during the test.

A2.2.6.3.2.4 Only those position outputs that are reported as valid by the equipment need to be considered for the accuracy evaluation. In order to pass the test, 99.9 % of the position outputs must be reported as valid, excluding those position reports prior to the first position fix.

A2.2.6.3.3 GPS Simulator-based Accuracy Tests.

A2.2.6.3.3.1 The equipment SHALL be tested using a GPS simulator scenario that includes both static and dynamic aircraft manoeuvres. The horizontal and vertical position errors SHALL be computed for each position estimate output by the equipment.

A2.2.6.3.3.2 Monitor the sensor-provided HFOM and VFOM, or HFOM and VFOM derived from the sensor-provided HDOP and VDOP per paragraphs A1.2.5.8 and A1.2.5.10. In order to pass the test, the horizontal position error must be less than 30 metres for at least 95 % of the samples and the horizontal accuracy reported must be greater than the actual position error for at least 95 % of the samples. In order to pass the test, the vertical position error must be less than 45 metres for at least 95 % of the samples and the vertical accuracy reported must be greater than the actual position error for at least 95 % of the samples.

A2.2.6.3.3.3 The horizontal position error SHALL not exceed 0.5 NM at any time during the test.

A2.2.6.3.3.4 Simulator Scenario Details

A2.2.6.3.3.4.1 Only those position outputs that are reported as valid by the equipment need to be considered for the accuracy evaluation. In order to pass the test, 99.9 % of the position outputs must be reported as valid, excluding those position reports prior to the first position fix.

A2.2.6.3.3.4.2 The simulator scenario SHALL use the standard 24-satellite constellation in RTCA document DO-229E Appendix B. The initial position and time should be chosen to ensure the satellite geometry supports the test pass-fail criteria, and the HDOP is close to 2.5 and the VDOP is close to 3.7.

A2.2.6.3.3.4.3 The simulation SHALL include both stationary and dynamic portions, as follows:

A2.2.6.3.3.4.3.1 At least 10 minutes of stationary position.

A2.2.6.3.3.4.3.2 A sequence of different manoeuvres, including acceleration to a constant velocity, climbs, descents, and turns.

A2.2.6.3.3.4.3.2.1 A series of turns should be included to ensure a constantly changing velocity to expose any effects of filtering on the position output.

A2.2.6.3.3.4.3.3 At least 10 minutes of accelerated manoeuvres SHALL be simulated.

A2.2.6.3.3.4.3.4 Aircraft dynamics are as follows: ground speed = 200 kt, horizontal acceleration=0.58 g, vertical acceleration of 0.5 g.

A2.2.6.3.3.4.4 The simulated satellite signals SHALL be set to -134 dBm while position measurements are taken. Signal powers may be increased at the beginning of the scenario to allow for initial acquisition.

A2.2.6.3.3.4.5 Simulated signals SHALL include ranging errors for atmospheric effects (troposphere and ionosphere) that adhere to approved models. Refer to DO-229E, Appendix A, Section A.4.2.4 and IS-GPS-200G, dated 5 September 2012.

A2.2.6.3.3.4.6 No interference needs to be simulated.

A.2.2.6.4 Reserved.

A2.2.6.5 Velocity Accuracy Tests.

A2.2.6.5.1 The velocity accuracy tests specified in AC 20-138D Appendix 4, Sections 4-2, 4-3 and 4-4, SHALL be performed per the requirement in A1.2.6.5 and show the unit provides an accuracy of 10 m/s or less, at least 95 % of the time. It is assumed that the GPS position source does not provide a velocity accuracy output and the TABS will broadcast NACv = 1. Only the tests required to demonstrate a NACv = 1 need be run.

A2.2.6.6 Interference Tests.

A2.2.6.6.1 The equipment SHALL be tested using simulated GPS signals mixed with an interfering signal of gradually increasing power until the equipment loses position to verify the requirement outlined in paragraph A1.2.6.6. The horizontal position accuracy will be evaluated.

A2.2.6.6.2 Simulator Scenario Details.

A2.2.6.6.2.1 Use the same simulator scenario set-up found in A2.2.6.3.3.4 with the following exceptions:

A2.2.6.6.2.2 The interfering signal SHALL be broadband noise with bandwidth of 20 MHz centred on 1575.42 MHz. The initial power spectral density SHALL be -170.5 dBm/Hz (-97.5 dBm total power).

A2.2.6.6.2.3 The scenario may need to be extended to allow sufficient time for increasing interference power.

A2.2.6.6.3 Test Procedure

A2.2.6.6.3.1 Step 1: The interfering signal SHALL initially be turned off.

A2.2.6.6.3.2 Step 2: The simulator scenario SHALL be engaged and the satellites' RF SHALL be turned on.

A2.2.6.6.3.3 Step 3: The equipment SHALL be powered on and initialized. It is assumed that the receiver has obtained a valid almanac for the simulator scenario to be tested prior to conducting these tests.

A2.2.6.6.3.4 Step 4: The receiver SHALL be allowed to reach steady state. When the receiver has reached steady state, an interfering broadband noise signal of -170.5 dBm/Hz SHALL be applied.

A2.2.6.6.3.5 Step 5: The interference power SHALL be maintained until the accuracy has reached steady state. Position measurements and validity indications SHALL be recorded during this interval.

A2.2.6.6.3.6 Step 6: The power of the interfering signal SHALL be increased by 2 dB and maintained for 200 seconds.

A2.2.6.6.3.7 Step 7: Go to Step 5 and repeat until the receiver is unable to maintain a position fix.

A2.2.6.6.4 Pass-Fail Criteria

A2.2.6.6.4.1 The horizontal position errors SHALL be computed for each position estimate output by the equipment.

A2.2.6.6.4.2 The horizontal position error SHALL not exceed 0.5 NM at any time during the test.

A2.2.6.6.4.3 Only those position outputs that are reported as valid by the equipment need to be considered for the accuracy evaluation. There is no minimum interference rejection requirement for TABS equipment, and loss of position in the presence of interference is acceptable behaviour.

A2.2.6.7 Verification of SBAS Message Type 0

A2.2.6.7.1 Test to verify that the GNSS position source does not use SBAS corrections when the SBAS satellite is broadcasting message type 0 per A1.2.6.7.

A2.2.6.7.2 Simulator Scenario Details

A2.2.6.7.2.1 The simulator scenario SHALL use the standard 24-satellite constellation in RTCA document DO-229E Appendix B.

A2.2.6.7.2.2 A single SBAS satellite SHALL be simulated with a fast corrections (MT 2-5) update rate of 6 seconds.

A2.2.6.7.2.3 At 500 seconds into the scenario, the SBAS satellite SHALL start broadcasting message type 0 for 60 seconds. The message type 0 broadcast SHALL contain message type 2 data (if appropriate for the SBAS service being simulated).

A2.2.6.7.2.4 The scenario SHALL have a static user position.

A2.2.6.7.2.5 The simulated satellite signals SHALL be set to a nominal power level (-128 dBm).

A2.2.6.7.2.6 Simulated signals SHALL include ranging errors for atmospheric effects (troposphere and ionosphere) that adhere to approved models. Refer to DO-229E Appendix A Section A.4.2.4 and IS-GPS-200G, dated 5 September 2012.

A2.2.6.7.2.7 No interference needs to be simulated.

A2.2.6.7.3 Test Procedure

A2.2.6.7.3.1 Step 1: The simulator scenario SHALL be engaged and the satellites' RF SHALL be turned on.

A2.2.6.7.3.2 Step 2: The equipment SHALL be powered on and initialised. It is assumed that the receiver has obtained a valid almanac for the simulator scenario to be tested prior to conducting the tests.

A2.2.6.7.3.3 Step 3: Monitor the receiver output for the indication of SBAS use. Verify that the receiver indicates that SBAS is not in use before an SBAS satellite has been acquired.

A2.2.6.7.3.4 Step 4: Allow the receiver to reach steady-state navigation. Verify that the receiver indicates that SBAS is in use before proceeding to the next step.

A2.2.6.7.3.5 Step 5: 500 seconds into the scenario, the SBAS satellite SHALL start broadcasting message type 0.

A2.2.6.7.3.6 Step 6: Monitor the receiver output for the indication of SBAS use. Verify that the receiver indicates that SBAS is not used within 8 seconds.

A2.2.6.8 Exclusion of satellites identified by SBAS as unhealthy

A2.2.6.8.1 Test to verify that the GNSS position source excludes satellites with UDREI=15 reported in the SBAS fast corrections per A1.2.6.8. The ability of the position source to exclude unhealthy satellites based on the SBAS UDREI will be tested by injecting a ramp error on a satellite measurement and subsequently broadcasting an SBAS UDREI of 15 ('do not use') for that satellite.

A2.2.6.8.2 UDREI = 15 in fast corrections message (MT 2-5, 24)

A2.2.6.8.2.1 The equipment SHALL be tested to verify that the UDREI data contained in the SBAS fast corrections messages (MT 2-5, 24) is used to exclude unhealthy satellites.

Note: The test does not assume that the receiver outputs an indication that the unhealthy satellite has been removed from the position solution. Instead, it uses a pass criterion based on horizontal position error.

A2.2.6.8.2.2 Simulator Scenario Details

A2.2.6.8.2.2.1 The simulator scenario SHALL use the standard 24-satellite constellation in RTCA document DO-229E Appendix B.

A2.2.6.8.2.2.2 A single SBAS satellite SHALL be simulated with a fast corrections (MT 2-5, 24) update rate of 6 seconds. The integrity information message (MT 6) SHALL not be broadcast.

A2.2.6.8.2.2.3 The simulation start time and location SHALL be such that the resulting HDOP is close to 5.0.

A2.2.6.8.2.2.4 The simulation SHALL use nominal aircraft dynamics, defined to be ground speed = 200 knots and horizontal acceleration = 0.58 g. These dynamics can be simulated as a series of turns.

A2.2.6.8.2.2.5 The scenario SHALL allow the receiver time to achieve steady-state navigation before introducing any satellite errors.

A2.2.6.8.2.2.6 The scenario SHALL introduce a ramp error on each simulated GPS satellite individually, as follows:

A2.2.6.8.2.2.6.1 Step 1: A 5-m/s ramp error SHALL be introduced on the simulated GPS satellite.

A2.2.6.8.2.2.6.2 Step 2: 6 seconds after the introduction of the ramp error, the simulated SBAS satellite SHALL broadcast a UDREI of 15 for the GPS satellite in the fast correction message.

A2.2.6.8.2.2.6.3 Step 3: The ramp error SHALL be applied until one of the following conditions occur:

1. The horizontal position error of a valid position output exceeds 0.5 NM; or
2. The ramp error exceeds 2 000 m; or
3. The affected GPS satellite is excluded from the solution.

A2.2.6.8.2.2.6.4 Step 4: Allow the receiver time to return to steady state before repeating Steps 1 to 3 on the next satellite.

A2.2.6.8.2.2.7 The simulated satellite signals SHALL be set to -134 dBm while position measurements are taken. Signal powers may be increased at the beginning of the scenario to allow for initial acquisition.

A2.2.6.8.2.2.8 Simulated signals SHALL include ranging errors for atmospheric effects (troposphere and ionosphere) that adhere to approved models. Refer to DO-229E, Appendix A, Section A.4.2.4 and IS-GPS-200G dated 5 September 5 2012.

A2.2.6.8.2.2.9 No interference needs to be simulated.

A2.2.6.8.2.3 Pass-Fail Criteria

A2.2.6.8.2.3.1 The test SHALL be run on two different space-time scenarios. The two scenarios SHALL be sufficiently separated to ensure that different satellite geometry is presented to the receiver.

A2.2.6.8.2.3.2 The horizontal position errors SHALL be computed for each position estimate output by the equipment during the test.

A2.2.6.8.2.3.3 The horizontal position error SHALL not exceed 0.5 NM at any time during the test.

A2.2.6.8.2.3.4 Only those position outputs that are reported as valid by the equipment need to be considered for the accuracy evaluation.

A2.2.6.9 Testing GNSS Position Source SBAS Fast and Long-Term Corrections

A2.2.6.9.1 Application of Fast Corrections (MT 2-5, 24) and Long-Term Corrections (MT 24, 25). The equipment SHALL be tested to verify that fast corrections and long-term corrections are applied properly per A1.2.6.9.

A2.2.6.9.2 Simulator Scenario Details

A2.2.6.9.2.1 The simulator scenario SHALL use the standard 24-satellite constellation in RTCA document DO-229E Appendix B.

A2.2.6.9.2.2 A single SBAS satellite SHALL be simulated with a fast corrections (MT 2-5, 24) update rate of 6 seconds and standard long-term corrections (MT 24, 25) update rate of 120 seconds.

A2.2.6.9.2.3 The simulation start time and location SHALL be such that the resulting HDOP is close to 5.0.

A2.2.6.9.2.4 The simulation SHALL use nominal aircraft dynamics, defined to be ground speed = 200 kt and horizontal acceleration = 0.58 g. These dynamics can be simulated as a series of turns.

A2.2.6.9.2.5 The scenario SHALL introduce a bias and ramp error on a single satellite selected so that the range error will result in the maximum horizontal position error if not corrected by SBAS. The SBAS long-term corrections will be applied to correct the bias error. At each 6-second update, SBAS fast corrections will be provided to correct the ramp error for the affected satellite, as follows:

A2.2.6.9.2.5.1 Step 1: A 70-metre bias SHALL be introduced on the simulated GPS satellite. Provide SBAS long-term corrections to correct the bias term. The bias magnitude was chosen to approximate the maximum value that can be corrected by the $\delta a f_0$ term in a type 25 message (using velocity code 0).

A2.2.6.9.2.5.2 Step 2: Start the scenario broadcasting MT25 with the correction for the bias error introduced on the selected satellite.

A2.2.6.9.2.5.3 Step 3: Allow the receiver time to acquire the GPS and SBAS satellites and obtain a steady-state differential fix, including sufficient time to acquire a type 25 message for the selected GPS satellite.

A2.2.6.9.2.5.4 Step 4: Inject a 5-m/s ramp error on the selected satellite in the same direction as the bias error.

A2.2.6.9.2.5.5 Step 5: At each 6-second update, provide SBAS fast corrections equivalent to the size of the growing ramp error.

A2.2.6.9.2.5.6 Step 6: The ramp error SHALL be applied until the ramp error plus bias error reaches 325 metres. Maintain the error of 325 metres for 5 minutes.

A2.2.6.9.2.6 The simulated satellite signals SHALL be set to -134 dBm while position measurements are taken. Signal powers may be increased at the beginning of the scenario to allow for initial acquisition.

A2.2.6.9.2.7 Simulated signals SHALL include ranging errors for atmospheric effects (troposphere and ionosphere) that adhere to approved models. Refer to DO-229E Appendix A Section A.4.2.4 and IS-GPS-200G dated September 5, 2012.

A2.2.6.9.2.8 No interference needs to be simulated.

A2.2.6.9.3 Pass-Fail Criteria

A2.2.6.9.3.1 The horizontal and vertical position errors SHALL be computed for each position estimate output by the equipment during the test.

A2.2.6.9.3.2 Monitor the sensor-provided HFOM and VFOM, or HFOM and VFOM derived from the sensor-provided HDOP and VDOP per paragraphs A1.2.5.8 and A1.2.5.10. Compare the HFOM against the horizontal position error for each valid position estimate. Compare the VFOM against the vertical position error for each valid position estimate. In order to pass the test, the horizontal and vertical position accuracy output must be greater than the actual position error at least 95 % of the time. Analyse the position estimates to determine whether the fast corrections and long-term corrections are being applied correctly.

A2.2.6.9.3.3 Only those position outputs that are reported as valid by the equipment need to be considered for the accuracy evaluation.

A2.2.6.9.3.4 The test only needs to be run using a single space/time scenario.

A2.2.6.10 Test the GNSS position source requirements in Section 0 by running the test outlined in Section A2.2.6.3.3.

[Amdt ETSO/13]

[Amdt ETSO/16]

Appendix 3 to ETSO-C199 A1 – Environmental Testing for Class B Equipment

ED Decision 2020/011/R

A3 Environmental Test Considerations

A3.1 The environmental tests and performance requirements described in this subsection provide a laboratory means of determining the overall performance characteristics of the equipment under conditions that are representative of those that may be encountered in actual aeronautical operations.

A3.2 The following test procedures must be run when performing environmental testing on Class B equipment. Class B equipment only needs to be tested under DO-160D change 3 or later Environmental Test, Section 4 Temperature and Altitude, and Section 5 Temperature Variation Testing.

A3.3 The test procedure provided below is considered satisfactory for use in determining the performance of the equipment under environmental conditions. Although specific test procedures are cited, it is recognised that other methods may be preferred. These alternative procedures may be used if the manufacturer can show that they provide at least equivalent information. In such cases, the procedures cited herein should be used as one criterion in evaluating the acceptability of the alternative procedures.

Note: The intent of this section is to minimise the testing of commercial off-the-shelf (COTS) devices.

A3.4 Class B Equipment System Test

A3.4.1 Equipment Required: A representative antenna of what will be installed in an actual airborne TABS.

A3.4.2 Figure 1 provides a representation of the test setup.

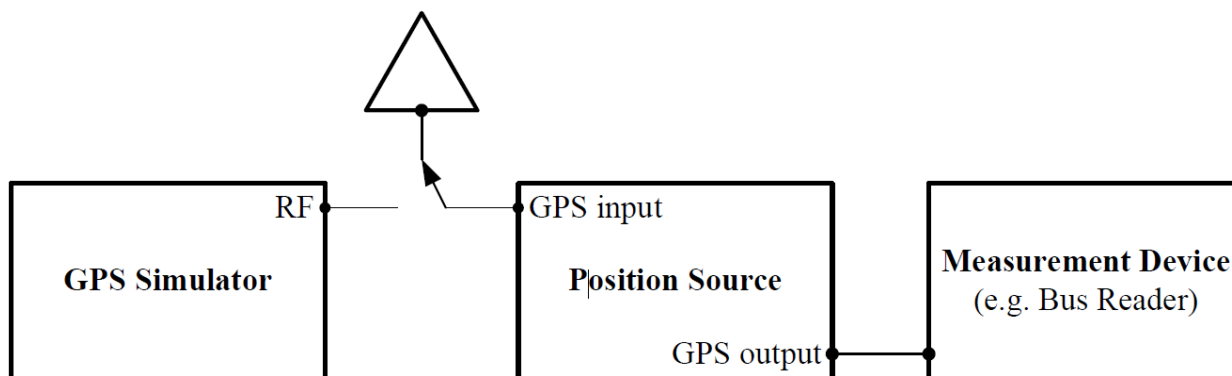

Figure 1 — Test Set-up

A3.4.3 Measurement Procedure:

A3.4.3.1 Set the test equipment to measure the output of the position source.

A3.4.3.1.1 Verify that the position information output by the GPS to the TABS is correct for:

A3.4.3.1.1.1 The latitude and longitude of the surveyed location when connecting the device to a live (e.g. rooftop) antenna, or;

A3.4.3.1.1.2 The output by the GPS simulator for the scenario outlined in Section A2.2.6.3.3

A3.4.3.1.2 Using the test set-up in A3.4.2, monitor the sensor-provided HFOM, or HFOM derived from the sensor-provided HDOP per paragraph A1.2.5.8. This output SHALL be compared against the horizontal position error for each valid position estimate. In order to pass the test, the horizontal position accuracy output must be greater than the actual position error for at least 95 % of the samples. The horizontal position error SHALL not exceed 0.5 NM at any time during the test.

[Amdt ETSO/13]

[Amdt ETSO/16]

ETSO-C207a

ED Decision 2020/011/R (applicable from 25.7.2020)

AERONAUTICAL MOBILE AIRPORT COMMUNICATION SYSTEM (AEROMACS)**1 Applicability**

This ETSO provides the requirements which aeronautical mobile airport communication system (AeroMACSs) that are designed and manufactured on or after the date of this ETSO must meet in order to be identified with the applicable ETSO marking.

2 Procedures

2.1 General

The applicable procedures are detailed in CS-ETSO, [Subpart A](#).

2.2 Specific

None.

3 Technical Conditions

3.1 Basic

3.1.1 Minimum performance standard

The applicable standards are those provided in EUROCAE ED-223, minimum operational performance standard (MOPS) for aeronautical mobile airport communication system (AeroMACS), dated October 2013.

Note: AeroMACS equipment may provide access in the airport environment to one or more of the following services: air traffic services (ATS), aeronautical operational communication (AOC) including aeronautical information services and meteorological (AIS/MET) information, airline administrative communication (AAC), and airport authority communication, as well as aircraft access to system-wide information management (SWIM) services. AeroMACS AMS equipment is intended for use while on the airport surface only. Passenger information and entertainment service and passenger-owned devices are not included in this ETSO. AeroMACS is considered to be supplemental to the communication equipment required by the operational rules. AeroMACS is based on the Institute of Electrical and Electronics Engineers 802.16-2009 standard: Air interface for broadband wireless access systems and can only operate on the airport surface.

3.1.2 Environmental Standard

See CS-ETSO, [Subpart A](#), paragraph 2.1.

3.1.3 Software

See CS-ETSO, [Subpart A](#), paragraph 2.2.

3.1.4 Airborne electronic hardware

See CS-ETSO, [Subpart A](#), paragraph 2.3.

3.2 Specific

None.

3.2.1 Failure Condition Classification

See CS-ETSO, [Subpart A](#), paragraph 2.4.

A failure of the function defined in paragraph 3.1.1 of this ETSO that results in misleading data link communication is a minor failure condition. A loss of this function is a minor failure condition. The minor failure condition classification is based on the network protocol and/or application system layers above the AeroMACS AMS equipment to detect and annunciate errors that would result in misleading or missing ATS messages.

4 Marking

4.1 General

See CS-ETSO, [Subpart A](#), paragraph 1.2.

4.2 Specific

None.

5 Availability of Referenced Documents

See CS-ETSO, [Subpart A](#), paragraph 3.

[Amdt ETSO/12]

[Amdt ETSO/16]

ETSO-C209

ED Decision 2018/002/R (applicable from 20/2/2018)

ELECTRONIC FLIGHT INSTRUMENT SYSTEM (EFIS) DISPLAY**1 Applicability**

This ETSO provides the requirements which electronic flight instrument system (EFIS) displays that are designed and manufactured on or after the date of this ETSO must meet in order to be identified with the applicable ETSO marking.

2 Procedures

2.1 General

Applicable procedures are detailed in CS-ETSO, [Subpart A](#).

2.2 Specific

None.

3 Technical Conditions

3.1 Basic

3.1.1 Minimum Performance Standard

Standards set forth in SAE AS6296, Electronic Flight Instrument System (EFIS) Display, dated March 2016, and AS8034B, Minimum Performance Standard for Airborne Multipurpose Electronic Displays, dated 27th June 2011.

Note1: The hardware, physical, and optical (ocular) requirements of EFIS displays are addressed in SAE AS8034B. The EFIS display requirements, expressed for a broad set of aircraft functions, are addressed in SAE AS6296.

Note2: This ETSO standard covers basic display standards (SAE AS8034B) and specific displayed functions requirements (SAE AS6296). Specific displayed functions can include, but are not limited to, flight instrumentation, navigation, engine and system status, alerting, surveillance, communication, terrain awareness, weather, and/or other displays. This ETSO standard does not provide standards for head up displays. Two functions covered within SAE AS6296 are required as a minimum. This ETSO does not address sensor requirements. This ETSO standard does not address the display of single function equipment (e.g., airspeed). Sensor requirements and single function equipment requirements are located in their respective ETSO.

3.1.2 Environmental Standard

See CS-ETSO, [Subpart A](#), paragraph 2.1.

3.1.3 Software

See CS-ETSO, [Subpart A](#), paragraph 2.2.

3.1.4 Airborne Electronic Hardware

See CS-ETSO, [Subpart A](#), paragraph 2.3

3.2 Specific

None.

3.2.1 Failure Condition Classification

See CS-ETSO, [Subpart A](#), paragraph 2.4

The failure condition classification appropriate for the equipment will depend on the intended use of the equipment in a specific aircraft. The loss of function and malfunction failure condition classification for which the equipment is designed should be documented.

4 Marking

4.1 General

Marking as detailed in CS-ETSO, [Subpart A](#), paragraph 1.2.

4.2 Specific

Per SAE AS6296 Section 3.14, a specific marking is required:

‘See Installation Manual (IM) for Declared EFIS Functions’, or equivalent, on the primary (most prominent) component of the EFIS.

5 Availability of Referenced Document

See CS-ETSO, [Subpart A](#), paragraph 3.

[Amdt ETSO/13]

ETSO-C210

ED Decision 2018/002/R (applicable from 20/2/2018)

AIRBORNE HEAD-UP DISPLAY**1 Applicability**

This ETSO provides the requirements which airborne head up displays that are designed and manufactured on or after the date of this ETSO must meet in order to be identified with the applicable ETSO marking.

This ETSO standard does not address enhanced vision systems (either infrared, millimeter wave or other imaging technologies), displays worn by the pilot (goggles, helmet-mounted displays) or specific symbology to be displayed.

2 Procedures**2.1 General**

Applicable procedures are detailed in CS-ETSO, [Subpart A](#).

2.2 Specific

None.

3 Technical Conditions**3.1 Basic****3.1.1 Minimum Performance Standard**

Standards set forth in SAE AS8055A, Minimum Performance Standards for Airborne Head Up Display, dated July 2015.

Some requirements of SAE AS8055A Section 4 are installation-dependent and cannot be fully verified at TSO article level. When the manufacturer is not able to test the TSO article in conditions representative of the overall range of the intended installation cases:

- the installation conditions for which the manufacturer has performed the test should be documented
- the installation procedures must define the functional qualification required to ensure the installed performance meets AS8055A.

3.1.2 Environmental Standard

See CS-ETSO, [Subpart A](#), paragraph 2.1.

3.1.3 Software

See CS-ETSO, [Subpart A](#), paragraph 2.2.

3.1.4 Airborne Electronic Hardware

See CS-ETSO, [Subpart A](#), paragraph 2.3.

3.2 Specific

None.

3.2.1 Failure Condition Classification

See CS-ETSO, [Subpart A](#), paragraph 2.4.

The failure condition classification appropriate for the equipment will depend on the intended use of the equipment in a specific aircraft. The loss of function and malfunction failure condition classification for which the equipment is designed should be documented, considering also obstructions to the pilot's field of view resulting from potential malfunction conditions.

4 Marking

4.1 General

Marking as detailed in CS-ETSO, [Subpart A](#), paragraph 1.2.

4.2 Specific

None

5 Availability of Referenced Document

See CS-ETSO, [Subpart A](#), paragraph 3.

[Amdt ETSO/13]

ETSO-C214 A1

ED Decision 2020/011/R (applicable from 25.7.2020)

FUNCTIONAL ETSO EQUIPMENT USING AN ETSO-2C153A-AUTHORISED IMA PLATFORM OR MODULE

1 Applicability

This ETSO standard is applicable to any equipment presented for an ETSO authorisation to a functional⁶ ETSO standard, where the equipment implements one (or several) [ETSO-C153a](#)-authorised IMA platforms/modules for which the applicant seeks compliance credit from these ETSO authorisations to demonstrate compliance with a functional ETSO.

Note: This ETSO standard is also applicable to any equipment for which an applicant is seeking an ETSO authorisation of a functional ETSO standard where the applicant performs additional development on an already authorised ETSO-C214 ‘open’ class article and intends to take compliance credit from this authorisation to demonstrate compliance with further functional ETSO standards.

This ETSO standard provides the requirements which functional ETSO equipment using an [ETSO-C153a](#)-authorised IMA platform or module or integrating further an ETSO-C214-authorised article that is designed and manufactured on or after the date of this ETSO must meet in order to be identified with the applicable ETSO marking.

EUROCAE ED-124 and RTCA document DO-297 recognise incremental IMA system approval by introducing intermediate acceptance steps. [ETSO-C153a](#) authorisation is the first step in the ETSO IMA authorisation process. This ETSO-C214 standard is an intermediate step to authorise functional ETSO equipment (F-ETSO equipment)⁷ implementing an [ETSO-C153a](#)-authorised IMA platform or IMA module, when the applicant is seeking compliance credit from these preceding authorisations to demonstrate compliance with a functional ETSO standard. This ETSO standard defines the requirements and delta activities that shall be performed for the authorisation of the integrated F-ETSO equipment.

Note: This ETSO standard does not define the minimum operational performance specifications of the defined function; these are defined by the individual ‘functional’¹ ETSO standard, with which the applicant may elect to comply (refer to CS-ETSO [Subpart A](#), Section 2.5).

2 Procedures

2.1 General

The applicable procedures are detailed in CS-ETSO, [Subpart A](#).

2.2 Specific

2.2.1 Access to the information of the selected ETSO-C153a platforms/modules

The applicant is responsible for establishing the necessary communication channels with the ETSO-C153a holder company.

The applicant shall have access to all necessary design data as a ‘user’ of the [ETSO-C153a](#) platform (for instance, the declaration of design performance, user

⁶ Functional ETSO standard: any ETSO standard of CS-ETSO describing an aircraft function, i.e. typically the majority of all ETSO standards except ETSO-C153a and this ETSO-C214.

⁷ ‘F-ETSO equipment’ is the integrated equipment for which the applicant is seeking an ETSO standard approval, using ETSO-C153a platform(s)/module(s).

guide/manual per [ETSO-C153a Appendix 3](#), installation manual, environmental qualification plans/reports, etc.).

The applicant's organisation shall establish a communication means to obtain timely notifications of design changes, open problem reports (at least the ones impacting the usage of the platform), occurrence reports and airworthiness directives (ADs) that affect or relate to the [ETSO-C153a](#) platforms/modules.

2.2.2 Assessment of design changes

The applicant shall perform a change impact analysis on [ETSO-C153a](#) platform design evolutions on the functional ETSO equipment, and shall perform the necessary development life cycle activities that are impacted by the [ETSO-C153a](#) changes.

Note: The functional ETSO holder is responsible for assessing the classification of the changes to the F-ETSO equipment as minor or major as per Part 21.A.611 and for providing the necessary associated justification.

Change management processes shall be compliant with AMC 20-170 Section 5.4.

2.2.3 Assessment and reporting of open problem reports (OPRs)

The management, analysis and classification of OPRs shall be performed by the applicant following the objectives of CS-ETSO Subpart A, Section 2.7 and AMC 20-170 Section 5.5, for which objective a) of that section is adapted to the F-ETSO context as follows:

- a) *The reporting of open problem reports (OPRs) between the different [ETSO-C153a](#) platforms/modules and the F-ETSO equipment shall be established and assessed by the F-ETSO applicant.*

3 Technical conditions

3.1 Basic

3.1.1 Minimum performance standard

This section provides the minimum performance standard requirements for the process of further development of equipment using an [ETSO-C153a](#)-authorised platform(s)/module(s) for which a functional ETSO authorisation (defined as the F-ETSO equipment) is sought.

The process requirements will cover the environmental qualification, the hardware development assurance, software development assurance and finally the integration of these developed items into the F-ETSO equipment to demonstrate compliance for the intended function, using the credit of the authorised [ETSO-C153a](#) platform(s)/module(s).

Definition of classes

This ETSO is an incremental step between [ETSO-C153a](#) and complete IMA systems certified during an aircraft type certification. Depending on the future evolution of the F-ETSO equipment, two classes have been defined:

- 'open' class, and
- 'closed' class.

'Open' class refers to an ETSO article that has been integrated taking into account the provisions for future evolution (*) of the ETSO article but restricted to an IMA

context. That means that there are still shared resources available after the integration of all the functions of the F-ETSO article, and that the performance and usage constraints of the remaining resources have been characterised.

‘Closed’ class refers to ETSO articles that have been integrated and where no evolution (*) has been anticipated, with all IMA-related activities considered closed. The performance of the remaining resources is not characterised. An F-ETSO ‘closed’ class article no longer offers the capability for IMA development. Design changes may still be performed in accordance with the Part 21 provisions, as for other ETSO articles.

() The term ‘evolution’ in these sentences refers to further development of functions using the remaining resources of the IMA, and without affecting the performance of the already authorised F-ETSO function.*

Class	Minimum performance standard
‘Open’	Section 3 of this document and Appendix 1
‘Closed’	Section 3 of this document

3.1.1.1 Use of ‘[ETSO-C153a](#)’-authorised platforms/modules

Identification of the ETSO-C153a platforms/modules used

- (a) The applicant shall clearly define the [ETSO-C153a](#) platforms/modules used in the design and the associated [ETSO-C153a](#) authorisation credit that is intended to be used for the F-ETSO equipment compliance demonstration.
- (b) The ETSO approval and the part number of the [ETSO-C153a](#) platforms/modules used shall be clearly referenced in the ETSO certification programme. The ETSO approval and the part number, including the issue/minor revisions of the [ETSO-C153a](#) platforms/modules used, shall be clearly referenced in the declaration of design and performance (DDP).
- (c) Any resources/functions included in the [ETSO-C153a](#) platforms/modules but unused in the current F-ETSO equipment shall be clearly identified in the ETSO certification programme or any related software/hardware plans.
- (d) The applicant shall identify and quantify the usage (used and unused features) of the [ETSO-C153a](#) platform resources, including the usage of its health monitoring and fault management resources.

Proper use of the ETSO-C153a platform(s)/module(s)

- (e) The applicant shall demonstrate the proper use of the [ETSO-C153a](#) platform(s)/module(s), including compliance with the [ETSO-C153a](#) platform integration requirements/user requirements and with the requirements for the correct use of platform safety features. In particular, the applicant shall demonstrate that the use, the partitioning, the configuration of the resources and the installation of the items are performed on the [ETSO-C153a](#) platform/modules in compliance with the [ETSO-C153a](#) user manual, installation manual or equivalent data (as documented per [ETSO-C153a Appendix 3](#)). This also includes the deactivation or disabling of unused [ETSO-C153a](#)

functions/modules, when available, or the means to ensure that the intended function is performed without any interference from unused [ETSO-C153a](#) functions/modules.

3.1.1.2 Equipment/hardware/software development

The ETSO certification programme shall describe the F-ETSO equipment and its structural breakdown. This shall include the use and integration of the [ETSO-C153a](#)-authorised platform(s)/module(s) within the F-ETSO equipment. The F-ETSO equipment certification programme shall introduce the planning, the organisation, the division of tasks and the development, validation, integration, and verification activities conducted on the F-ETSO article, including the tool environment used for those activities.

Considerations regarding the content of this ETSO certification programme and guidance can be found in ED-124 Chapter 4.4.3, referring to 'IMA system certification plans'.

In particular, the ETSO certification programme shall indicate the structure of the life cycle data that will support the compliance demonstration with the ETSO requirements.

Non-ETSO functions

Any non-ETSO function embedded in the equipment shall be developed and integrated in conformance to the requirements of this section, in order to be able to demonstrate that it does not interfere with the ETSO functions.

Any non-ETSO functions embedded in the equipment shall be clearly identified as non-ETSO functions in the ETSO certification programme.

3.1.1.2.1 Hardware development

The applicant shall clearly define the additional hardware part that will be developed and integrated with the [ETSO-C153a](#) platforms/modules that are used.

The development of the hardware shall be compliant with CS-ETSO, Subpart A, Section 2.3.

3.1.1.2.2 Software/application development

- (a) The applicant shall clearly define the software applications that will be developed and integrated with the [ETSO-C153a](#) platforms/modules that are used and with any possible additional hardware.
- (b) The development of hosted applications shall be compliant with CS-ETSO, Subpart A, Section 2.2.
- (c) The development of the hosted applications executing on an ETSO-2C153 platform shall comply with the Task 2 objectives defined in ED-124/DO-297 Table A-2 and Chapter 4.3.1, except Objective 4.3.1.d, and with the following adaptation for Objective 4.3.1.a, where the ED-124/DO-297 text is replaced by:

Objective 4.3.1.a:

‘Demonstrate that each application performs its intended function and satisfies the related ETSO standard and [Subpart A](#) Section 2.2 requirements and the F-ETSO article requirements while properly utilising the appropriate platform resources and interfacing with other modules and/or applications.’

Particularly it shall be demonstrated that the hosted application on the ETSO-C153a platform/module complies with the user requirements provided by the [ETSO-C153a](#) provider (see the CS-ETSO/[ETSO-C153a](#) standard — [Appendix 3](#)).

- (d) Any non-ETSO application embedded in the ETSO article shall be developed in conformance to the above requirements (b) and (c) in order to be able to demonstrate that it does not interfere with the ETSO functions.

The associated life cycle data to demonstrate the above requirements shall be produced and organised to support the functional ETSO system integration objectives, and to show that the applications are executing correctly within the platform and module requirements and limitations.

Even though the objectives for the development of hosted applications remain applicable, when relevant, some activities/life cycle data might be combined with F-ETSO equipment activities/data (next section).

3.1.1.2.3 Equipment integration process

There are several levels of integration that are possible for functional ETSO equipment using [ETSO-C153a](#)-authorised platforms/modules, of which some examples are listed below:

- the integration of software applications on an [ETSO-C153a](#) platform;
- the integration of several [ETSO-C153a](#) modules to build an integrated equipment and its software applications; and
- the integration of additional hardware simultaneously with software applications, together with an [ETSO-C153a](#) platform/module or additional hardware, into an [ETSO-C153a](#) rack platform (class RH).

General objective

- (a) The applicant shall perform the integration of the [ETSO-C153a](#) platform(s) and modules used with any additional hardware and the hosted software applications. These integration activities have to be compliant with the ED-124/DO-297 Task 3 objectives defined in ED-124/DO-297 Table A-3 and Chapter 4.4.1, except Objective 4.4.1.a, and with the following adaptation for Objective 4.4.1.d where the ED-124/DO-297 text is replaced by:

Objective 4.4.1.d:

‘Demonstrate compliance with the applicable functional ETSO standards and related MOPS.’

Note: Even though the integration activities have their own objectives, when relevant, some activities/data might be combined with some activities/life cycle data of the development of the hosted applications (see Section 3.1.1.2.2).

Health monitoring and fault management

- (b) The applicant shall describe how the [ETSO-C153a](#) health monitoring and fault management resources are used and integrated with the other platform/modules/application features, resulting in the health monitoring and fault management of the functional ETSO equipment.

In particular:

Principles and mechanisms shall be defined in order to allow the consistent sharing of fault management data between [ETSO-C153a](#) module/platform resources and the functions of the ETSO article. Recovery mechanisms shall be defined to ensure the continuity of the functions of the ETSO article when needed.

Guidance on health monitoring and fault management can be found in ED-124 Chapters 3.6.1 to 3.6.7.

Guidance about health monitoring and fault management at the platform and application levels respectively can also be found in ED-124 Chapters 3.1.1.b.5 and 3.1.2.d.

Configuration data/parameter data items

- (c) AMC 20-170 Section 5.2 shall be followed.

Use of tools and tool qualification

- (d) AMC 20-170 Section 5.3 shall be followed.

3.1.1.2.4 Safety assessment

The safety assessment of the F-ETSO equipment shall consider the possible failures in the [ETSO-C153a](#) platform/modules used in the equipment that are described by the platform provider in their failure modes and effect analysis and the safety assessment of the F-ETSO equipment. If any assumptions have been made at the [ETSO-C153a](#) platform/modules level, they shall be validated by the F-ETSO safety assessment process.

Note: If additional hardware is added to an [ETSO-C153a](#) platform/module, it shall also be considered in the safety assessment.

3.1.2 Environmental standard

The applicant shall demonstrate the compliance of the integrated F-ETSO equipment with the environmental requirements identified in CS-ETSO Subpart A, paragraph 2.1.

If the applicant intends to reuse evidence from an earlier demonstration of compliance achieved by the [ETSO-C153a](#) platform/module, an assessment of the achieved performance shall be performed so as to identify any gaps between the

earlier qualification of the [ETSO-C153a](#) platform/module and the intended F-ETSO environment, in compliance with the requirements of Subpart A, Section 2.1. The qualification test plan of the F-ETSO shall clearly identify any additional qualification activities and any tests that need to be (re)performed considering the impact of the integration of several hardware platforms/modules, as well as the possible differences between the intended environment of the F-ETSO equipment and the environment for which the [ETSO-C153a](#) platform/modules were qualified.

3.1.3 Software

See Section 3.1.1.2.2 of this ETSO standard.

3.1.4 Airborne electronic hardware

See Section 3.1.1.2.1 of this ETSO standard.

3.2 Specific

The installation manual shall include all the data necessary for the proper installation and use of the F-ETSO equipment.

The installation manual shall document a means to ensure the compatibility between the authorised [ETSO-C153a](#) platform/module and the authorised F-ETSO article. In particular, the installation manual shall provide compatibility and mixability information between the IMA ETSO-C153a platform/module and the F-ETSO hosted application(s).

3.2.1 Failure condition classification

See CS-ETSO, [Subpart A](#), paragraph 2.4.

The failure condition classification that is appropriate for the ETSO article will not be driven by this ETSO standard but driven by the intended aircraft function and the minimum classification indicated in the functional ETSO standard with which the ETSO article is intended to comply.

4 Marking

4.1 General

See CS-ETSO, [Subpart A](#), paragraph 1.2.

4.2 Specific

The applicant shall mark the ETSO article with ETSO-C214 and the selected class of the equipment:

- ETSO-C214 'Open', or
- ETSO-C214 'Closed'.

The applicant shall maintain the original ETSO marking of the [ETSO-C153a](#) platform and modules used in the F-ETSO equipment. When the technique of electronic marking was used, this electronic marking shall remain available, even after having developed additional software.

5 Availability of Referenced documents

See CS-ETSO, [Subpart A](#), paragraph 3.

[Amdt ETSO/14]

[Amdt ETSO/16]

Appendix 1 to ETSO-C214 A1 – ‘Open’ class IMA equipment

ED Decision 2020/011/R

This Appendix is applicable to ‘open’ class IMA equipment.

1 IMA resources of ‘open’ class equipment

When the C214-ETSO article is of the ‘open’ class, the F-ETSO applicant needs to properly characterise and document the resulting platform resources and partitioning features for the next user.

Three main cases of ‘open’ equipment are distinguished in order to adapt the requirements to the development specificities of the F-ETSO article as follows:

- a) When the applicant uses only one [ETSO-C153a](#) platform and does not augment its resources, as illustrated below:

Shared resources of the F-ETSO equipment



Note: ETSO-*C153* is intended to identify any existing amendment of this ETSO including its first release as ETSO-2C153

...then the applicant shall describe the use of the original [ETSO-C153a](#) platform with regard to the [ETSO-C153a Appendix 3](#) data (such as the user guide) and describe the remaining resources with respect to that Appendix 3 data so that it is clear which shared resources remain available for future incremental development by an independent user or aircraft manufacturer. In particular, the resources that are used and allocated shall be described and quantified.

- b) When the F-ETSO equipment integrates multiple [ETSO-C153a](#)-authorised resources without augmenting the IMA sharing capability, as illustrated below:

Shared resources of the F-ETSO equipment

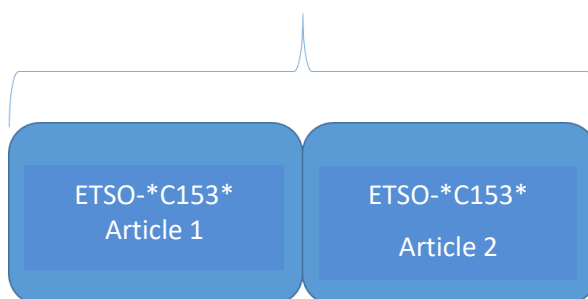

...the F-ETSO applicant shall characterise the resulting platform using the individual characterisation of the [ETSO-C153a](#) platform and document the resulting [ETSO-C214](#) ‘open’ platform in compliance with [ETSO-C153a Appendix 3](#).

c) When the F-ETSO equipment augments the IMA sharing resources with additional development (hardware and/or software), as illustrated below:

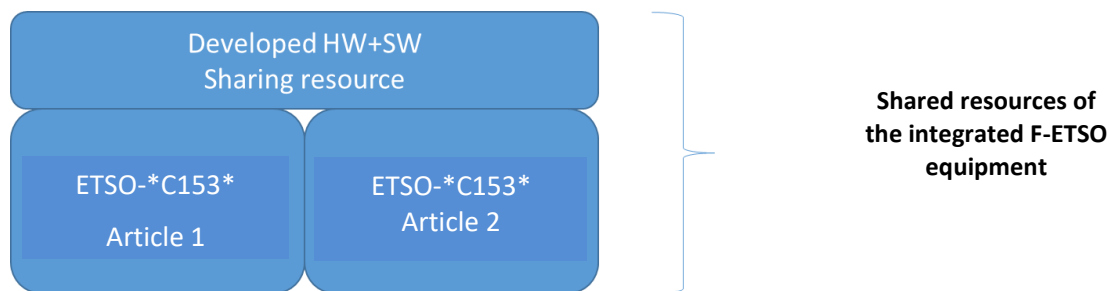

...the F-ETSO equipment development shall comply with [ETSO-C153a Appendix 2](#) and the related classes and document the augmented 'open' platform C214 in compliance with [ETSO-C153a Appendix 3](#).

The applicant can use the [Appendix 3 ETSO-C153a](#) data of the [ETSO-C153a](#) platform/modules that are used and augment or amend them to elaborate the [ETSO-C214](#) 'open' platform user data, in compliance with [ETSO-C153a Appendix 3](#).

Within the characterisation effort of resources, the applicant should in particular document the instructions for configuration of the [ETSO-C214](#) article so that the next user can ensure the integrity and continuity of the system configuration, and ensure that the resource allocation, partitioning, and health monitoring would not be impaired when integrating the ETSOA article.

2 Continuous health monitoring capability

As a user of an [ETSO-C153a](#) platform/modules, the F-ETSO applicant should pay particular attention to ensuring that there is a continuous health monitoring capability. Health monitoring features provided in an 'open' class platform shall be continuously maintained and characterised throughout the integration process, and the health monitoring capability shall be made available for any potential further incremental development.

[Amdt ETSO/14]

[Amdt ETSO/16]

INDEX 2

ETSO-2C19c A1

ED Decision 2020/011/R (applicable from 25.7.2020)

PORTABLE WATER-SOLUTION TYPE HAND FIRE EXTINGUISHERS

1 Applicability

This ETSO provides the requirements which portable water-solution type hand fire extinguishers that are designed and manufactured on or after the date of this ETSO must meet in order to be identified with the applicable ETSO marking.

2 Procedures

2.1 General

The applicable procedures are detailed in CS-ETSO, [Subpart A](#).

2.2 Specific

None.

3 Technical Conditions

3.1 Basic

3.1.1 Minimum Performance Standard

The applicable standards are those provided in SAE International's Aerospace Standard AS245B, Water Solution Type Hand Fire Extinguisher, dated 1 November 1948, revised in April 2000, as amended by [Appendix 1](#) to this ETSO.

3.1.2 Environmental Standard

See CS-ETSO, [Subpart A](#), paragraph 2.1

3.1.3 Software

None.

3.1.4 Airborne Electronic Hardware

See CS-ETSO, Subpart A, paragraph 2.3.

3.2 Specific

3.2.1 Failure Condition Classification

See CS-ETSO, Subpart A, paragraph 2.4.

4 Marking

4.1 General

See CS-ETSO, [Subpart A](#), paragraph 1.2.

Instead of the optional serial number, the date of manufacture has to be marked.

4.2 Specific

In addition to the requirements of paragraph 4.1, the marking requirements of SAE International's Aerospace Standard AS245B, paragraph 3.2 are applicable.

5 Availability of Referenced Document

See CS-ETSO, [Subpart A](#), paragraph 3

[Amdt ETSO/12]

[Amdt ETSO/16]

Appendix 1 to ETSO-2C19c A1 – MPS Portable Water Solution Type Hand Fire Extinguishers

ED Decision 2020/011/R

The applicable standard is SAE AS245B, Water Solution Type Hand Fire Extinguisher, dated (revised) April 2004, shall be modified as follows:

AS245B section	Action									
Paragraph 4.1.2: Burst pressure	<p>to be revised as follows: The burst pressure must be greater than or equal to ‘b’ times the design pressure (see Table 1 below). The design pressure is compatible with the maximum pressure encountered in use of the extinguisher and ensures a long service life for equipment when charged.</p>									
Paragraph 5. Individual Performance Requirements:	<p>to be revised as follows: All extinguishers, or extinguisher components shall be subjected at a minimum to the following tests:</p> <p>Requirement to be added: the proof pressure must be greater than or equal to ‘p’ times the design pressure (see table 1 below).</p> <p>Table 1: the ‘b’ and ‘p’ factors indicated depend on the type of extinguisher</p> <table border="1" style="margin-left: auto; margin-right: auto;"> <thead> <tr> <th></th> <th style="background-color: #cccccc;">b</th> <th style="background-color: #cccccc;">p</th> </tr> </thead> <tbody> <tr> <td style="text-align: center;">Type I</td> <td style="text-align: center;">2,7</td> <td style="text-align: center;">1,5</td> </tr> <tr> <td style="text-align: center;">Type II</td> <td style="text-align: center;">2,4</td> <td style="text-align: center;">1,2</td> </tr> </tbody> </table>		b	p	Type I	2,7	1,5	Type II	2,4	1,2
	b	p								
Type I	2,7	1,5								
Type II	2,4	1,2								

[Amdt ETSO/12]

[Amdt ETSO/16]

ETSO-2C123c

ED Decision 2020/011/R (applicable from 25.7.2020)

COCKPIT VOICE RECORDER SYSTEMS

1 Applicability

This ETSO provides the requirements that cockpit voice recorder (CVR) systems that are designed and manufactured on or after the date of this ETSO must meet in order to be identified with the applicable ETSO marking.

2 Procedures

2.1 General

The applicable procedures are detailed in CS-ETSO, [Subpart A](#).

2.2 Specific

All the information specified in EUROCAE ED-112A, Section 2-1, 2-1.3.4, excluding item 6, shall be documented in a manual and be made available to the accident investigation authorities on request. In addition, if special tools or recovery techniques are used to retrieve recorded information from any memory device that is used within the crash-protected memory module removed from a crash-damaged recorder, these tools/recovery techniques shall be also made available to the accident investigation authorities on request.

Note: Requests from accident investigation authorities can be independent of any ongoing investigation.

3 Technical Conditions

3.1 Basic

3.1.1 Minimum Performance Standard

The applicable standards are those provided in EUROCAE ED-112A, MOPS for Crash Protected Airborne Recorder Systems, dated September 2013, that pertain to the CVR type, except Chapters I-1 and I-6, and Sections 2-1.1, 2-1.5, 2-1.6, 2-1.11, 2-1.12, 2-3.1, 2-5, 3, Annex I-A, Annex I-C, and other ED-112A requirements related to installation, flight testing, aircraft maintenance as amended by Appendix 1 to this ETSO.

Table 1 lists CVR types and the ED-112A Section and Part containing the MPS for each type:

Table 1 — CVR MPS Requirements

CVR Type	ED-112A Reference
Single-function CVR in a <u>non-deployable</u> recorder	Section 2 and Part I.
CVR function in a <u>deployable</u> recorder	Section 2 (except for tests covered by ETSO-2C517) and Part I. The recorder shall also comply with ETSO-2C517.
CVR function in a <u>combined non-deployable</u> recorder	Section 2, Section 4, and Part I.

CVR function in a combined deployable recorder

Section 2 (except for tests covered by ETSO 2C517), Section 4 and Part I.
The recorder shall also comply with ETSO-2C517.

Note: A CVR article may cover multiple types. A CVR may be a combined CVR and may also be deployable, in which case the applicable MOPS are Sections 2, 4, Part I and the MOPS of ETSO 2C517, following the table above.

3.1.2 Environmental Standard

See CS-ETSO, [Subpart A](#), paragraph 2.1.

3.1.3 Software

See CS-ETSO, [Subpart A](#), paragraph 2.2.

3.1.4 Airborne Electronic Hardware

See CS-ETSO, [Subpart A](#), paragraph 2.3.

3.2 Specific

3.2.1 Failure Condition Classification

See CS-ETSO, [Subpart A](#), paragraph 2.4.

A failure of the function defined in paragraph 3.1.1 of this ETSO is a minor failure condition.

A loss of the function defined in paragraph 3.1.1 of this ETSO is a minor failure condition.

The applicant must develop the system to be at least the development assurance level that is commensurate with these failure conditions.

Note: The failure classification requirement is driven by the use of CVRs in accident investigations.

4 Marking

4.1 General

See CS-ETSO, [Subpart A](#), paragraph 1.2.

4.2 Specific

4.2.1 Lettering Identification

The equipment shall comply with the identification requirement in EUROCAE ED-112A, Section 2-1, paragraph 2-1.16.3, if it is fixed, and those of ETSO-2C517, if it is deployable.

5 Availability of Referenced Documents

See CS-ETSO, [Subpart A](#), paragraph 3.

[Amdt ETSO/6]

[Amdt ETSO/13]

[Amdt ETSO/16]

Appendix 1 to ETSO-2C123c – MPS for Crash-Protected Airborne Recorder Systems

ED Decision 2020/011/R

The standard EUROCAE ED-112a, MOPS for Crash Protected Airborne Recorder Systems, dated September 2013, shall be modified as per Table 1 below.

Table 1 — Modification of EUROCAE ED-112A

Location	Initial ED-112A text	Amending text
2-1.16.2 a. iii.	Impact shock, shear and tensile test, penetration resistance, static crush, deep sea pressure and sea water immersion.	Impact shock, shear and tensile test, penetration resistance, static crush, deep sea pressure and sea water immersion. Deep sea pressure and sea water immersion may be performed on two different units provided that both units undergo the rest of the sequence and that the period of the deep sea pressure test is 90 days.
2-4.2.7 a.	<p>Unless it can be shown that the recording medium can withstand the conditions associated with deep sea immersion and that it is unlikely to be damaged as a consequence of collapse of any protective armour, immerse the recorder in sea water at a pressure of 60 MPa (equivalent to a depth of 6 000 m (20 000 ft) for a period of 30 days.</p> <p>This period may be reduced to 24 hours provided that the methods and materials used to protect the recording medium have been shown to be unaffected by sea water. To avoid damage to the test equipment, this test may be performed using any suitable liquid in the pressure chamber itself together with a means to separate this liquid from the sea water in which the recorder is immersed.</p>	<p>Unless it can be shown that the recording medium can withstand the conditions associated with deep-sea immersion and that it is unlikely to be damaged as a consequence of the collapse of any protective armour or except if the recorder is deployed during or following impact with water, immerse the recorder in seawater at a pressure of 60 MPa (equivalent to a depth of 6 000 m, i.e. 20 000 ft) for a period of 90 days.</p> <p>This period may be reduced to 24 hours provided that the test is performed once more after the sea water immersion test in 2-4.2.7 b. To avoid damage to the test equipment, this test may be performed using any suitable liquid in the pressure chamber itself together with a means to separate this liquid from the seawater in which the recorder is immersed.</p>
2-4.2.7 b.	Unless it can be shown that the recording medium and the identification required by paragraph 2-1.16.3 are resistant to the corrosive effects of sea water, immerse the recorder in sea water at a depth of 3 m and nominal temperature of + 25°C for a period of 30 days.	Unless it can be shown that the recording medium and the identification required by paragraph 2-1.16.3 are resistant to the corrosive effects of seawater, immerse the recorder in seawater at a depth of 3 m and a temperature of at least + 25.0 °C for a period of 90 days.

[Amdt ETSO/16]

ETSO-2C124c

ED Decision 2020/011/R (applicable from 25.7.2020)

FLIGHT DATA RECORDER SYSTEMS

1 Applicability

This ETSO provides the requirements that flight data recorder (FDR) systems that are designed and manufactured on or after the date of this ETSO must meet in order to be identified with the applicable ETSO marking.

2 Procedures

2.1 General

The applicable procedures are detailed in CS-ETSO, [Subpart A](#).

2.2 Specific

All the information specified in EUROCAE ED-112A, Section 2-1, 2-1.3.4 excluding item 6, shall be documented in a manual and be made available to the accident investigation authorities on request. In addition, if special tools or recovery techniques are used to retrieve recorded information from any memory device used within the crash-protected memory module removed from a crash-damaged recorder, these tools/recovery techniques shall be also made available to the accident investigation authorities on request.

Note: Requests from accident investigation authorities can be independent of any ongoing investigation.

3 Technical Conditions

3.1 Basic

3.1.1 Minimum Performance Standard

The applicable standards are those provided in the applicable sections of EUROCAE ED-112A, MOPS for Crash Protected Airborne Recorder Systems, dated September 2013, that pertain to the FDR type, except Chapters II-1 and II-6, and Sections 2-1.1, 2-1.5, 2-1.6, 2-1.11, 2-1.12, 2-3.1, 2-5, 3, Annex II-A, Annex II-B, and other ED-112A requirements related to for aircraft-level equipment installation, flight testing, and aircraft maintenance as amended by Appendix 1 to this ETSO.

Table 1 lists FDR types and the ED-112A Section and Part containing the MPS for each type:

Table 1. Recorder MPS Requirements

Recorder Type	ED-112A Reference
Single-function FDR in a <u>non-deployable</u> recorder	Section 2 and Part II.
FDR function in a <u>deployable</u> recorder	Section 2 (except for tests covered by ETSO 2C517) and Part II. The recorder shall also comply with ETSO 2C517.
FDR function in a <u>combined non-deployable</u> recorder	Section 2, Section 4, and Part II.

FDR function in a combined deployable recorder

Section 2 (except for tests covered by ETSO 2C517), Section 4 and Part I. The recorder shall also comply with ETSO 2C517.

Note: An FDR article may cover multiple types. An FDR may be a combined FDR and may also be deployable, in which case the applicable MOPS are Sections 2, 4, Part I and the MOPS of ETSO 2C517, following the table above.

3.1.2 Environmental Standard

See CS-ETSO, [Subpart A](#), paragraph 2.1.

3.1.3 Software

See CS-ETSO, [Subpart A](#), paragraph 2.2.

3.1.4 Airborne Electronic Hardware

See CS-ETSO, [Subpart A](#), paragraph 2.3.

3.2 Specific

3.2.1 Failure Condition Classification

See CS-ETSO, [Subpart A](#), paragraph 2.3.

A failure of the function defined in paragraph 3.1.1 of this ETSO is a minor failure condition.

A loss of the function defined in paragraph 3.1.1 of this ETSO is a minor failure condition.

The applicant must develop the system to be at least the development assurance level that is commensurate with this failure condition.

Note: The failure classification requirement is driven by the use of FDRs in accident investigations.

4 Marking

4.1 General

See CS-ETSO, [Subpart A](#), paragraph 1.2.

4.2 Specific

4.2.1 Lettering Identification

The equipment shall comply with the identification requirement in EUROCAE ED-112A, Section 2-1, paragraph 2-1.16.3, if it is fixed, and those of ETSO-2C517, if it is deployable.

5 Availability of Referenced Documents

See CS-ETSO, [Subpart A](#), paragraph 3.

[Amdt ETSO/6]

[Amdt ETSO/13]

[Amdt ETSO/16]

Appendix 1 to ETSO-2C124c – MPS FOR CRASH-PROTECTED AIRBORNE RECORDER SYSTEMS

ED Decision 2020/011/R

The standard EUROCAE ED-112a, MOPS for Crash Protected Airborne Recorder Systems, dated September 2013, shall be modified as per Table 1 below.

Table 1 — Modification of EUROCAE ED-112A

Location	Initial ED-112A text	Amending text
2-1.16.2 a. iii.	Impact shock, shear and tensile test, penetration resistance, static crush, deep sea pressure and sea water immersion.	Impact shock, shear and tensile test, penetration resistance, static crush, deep sea pressure and sea water immersion. Deep sea pressure and sea water immersion may be performed on two different units provided that both units undergo the rest of the sequence and that the period of the deep sea pressure test is 90 days.
2-4.2.7 a.	<p>Unless it can be shown that the recording medium can withstand the conditions associated with deep sea immersion and that it is unlikely to be damaged as a consequence of collapse of any protective armour, immerse the recorder in sea water at a pressure of 60 MPa (equivalent to a depth of 6 000 m (20 000 feet) for a period of 30 days.</p> <p>This period may be reduced to 24 hours provided that the methods and materials used to protect the recording medium have been shown to be unaffected by sea water. To avoid damage to the test equipment, this test may be performed using any suitable liquid in the pressure chamber itself together with a means to separate this liquid from the sea water in which the recorder is immersed.</p>	<p>Unless it can be shown that the recording medium can withstand the conditions associated with deep-sea immersion and that it is unlikely to be damaged as a consequence of collapse of any protective armour or except if the recorder is deployed during or following impact with water, immerse the recorder in seawater at a pressure of 60 MPa (equivalent to a depth of 6 000 m, i.e. 20 000 ft) for a period of 90 days.</p> <p>This period may be reduced to 24 hours provided that the test is performed once more after the sea water immersion test in 2-4.2.7 b. To avoid damage to the test equipment, this test may be performed using any suitable liquid in the pressure chamber itself together with a means to separate this liquid from the seawater in which the recorder is immersed.</p>
2-4.2.7 b.	Unless it can be shown that the recording medium and the identification required by paragraph 2-1.16.3 are resistant to the corrosive effects of sea water, immerse the	Unless it can be shown that the recording medium and the identification required by paragraph 2-1.16.3 are resistant to the corrosive effects of seawater, immerse the recorder in seawater at a depth of

Location	Initial ED-112A text	Amending text
	recorder in sea water at a depth of 3 m and nominal temperature of +25°C for a period of 30 days.	3 m and a temperature of at least + 25.0 °C for a period of 90 days.

[Amdt ETSO/16]

ETSO-2C176a

ED Decision 2020/011/R (applicable from 25.7.2020)

AIRCRAFT COCKPIT IMAGE RECORDER SYSTEMS

1 Applicability

This ETSO provides the requirements that aircraft cockpit image recorder (CIR) systems that are designed and manufactured on or after the date of this ETSO must meet in order to be identified with the applicable ETSO marking.

2 Procedures

2.1 General

The applicable procedures are detailed in CS-ETSO, [Subpart A](#).

2.2 Specific

All the information specified in EUROCAE ED-112A, Section 2-1, 2-1.3.4, excluding item 6, shall be documented in a manual and be made available to the accident investigation authorities on request. In addition, if special tools or recovery techniques are used to retrieve recorded information from any memory device used within the crash-protected memory module removed from a crash-damaged recorder, these tools/recovery techniques shall be also made available to the accident investigation authorities on request.

Note: Requests from accident investigation authorities can be independent of any ongoing investigation.

3 Technical Conditions

3.1 Basic

3.1.1 Minimum Performance Standard

The applicable standards are those provided in the applicable sections of EUROCAE ED-112A, MOPS for Crash Protected Airborne Recorder Systems, dated September 2013 that pertain to the Cockpit Image Recorder (CIR) type, except chapters III-1 and III-6, and Sections 2-1.1, 2-1.5, 2-1.6, 2-1.11, 2-1.12, 2-3.1, 2-5, 3, Annex III-A, Annex III-B, and other ED-112A requirements related to aircraft-level equipment installation, flight testing, and aircraft maintenance as amended by Appendix 1 to this ETSO.

The table below lists the types of recorder and the ED-112A section or part that contains the MPS for each of them:

Table 1 — CIR MPS Requirements

CIR Type	ED-112 Reference
Single CIR in a non-deployable recorder	Section 2 and Part III.
CIR function in a deployable recorder	Section 2 (except for tests covered by ETSO-2C517) and Part III. The recorder shall also comply with ETSO-2C517.
CIR function in a combined non-deployable recorder	Section 2, Section 4 and Part III.

CIR Type	ED-112 Reference
CIR function in a <u>combined deployable</u> recorder	Section 2 (except for the tests covered by ETSO-2C517), Section 4 and Part I. The recorder shall also comply with ETSO-2C517.

Note: A CIR article may cover multiple types. A CIR may be a combined CIR and may also be deployable, in which case the applicable MOPS are in Sections 2, 4, Part I and the MOPS of ETSO-2C517, following the table above.

3.1.2 Environmental Standard

See CS-ETSO, [Subpart A](#), paragraph 2.1

3.1.3 Software

See CS-ETSO, [Subpart A](#), paragraph 2.2

3.1.4 Airborne Electronic Hardware

See CS-ETSO, [Subpart A](#), paragraph 2.3

3.2 Specific

3.2.1 Failure Condition Classification

See CS-ETSO, [Subpart A](#), paragraph 2.4.

A failure of the function defined in paragraph 3.1.1 of this ETSO is a minor failure condition.

A loss of the function defined in paragraph 3.1.1 of this ETSO is a minor failure condition.

Note: The failure classification requirement is driven by the use of recorders in accident investigations.

4 Marking

4.1 General

See CS-ETSO, [Subpart A](#), paragraph 1.2

4.2 Specific

4.2.1 Lettering Identification

The equipment shall comply with the identification requirement in EUROCAE ED-112A, Section 2-1, paragraph 2-1.16.3, if it is fixed, and those of ETSO-2C517, if it is deployable.

5 Availability of Referenced Documents

See CS-ETSO, [Subpart A](#), paragraph 3

[Amdt ETSO/6]

[Amdt ETSO/13]

[Amdt ETSO/16]

Appendix 1 to ETSO-C176a – MPS for Crash-Protected Airborne Recorder Systems

ED Decision 2020/011/R

The standard EUROCAE ED-112A, MOPS for Crash Protected Airborne Recorder Systems, dated September 2013, shall be modified as per Table 1 below.

Table 1 — Modification of EUROCAE ED-112A

Location	Initial ED-112A text	Amending text
2-1.16.2 a. iii.	Impact shock, shear and tensile test, penetration resistance, static crush, deep sea pressure and sea water immersion.	Impact shock, shear and tensile test, penetration resistance, static crush, deep sea pressure and sea water immersion. Deep sea pressure and sea water immersion may be performed on two different units provided that both units undergo the rest of the sequence and that the period of the deep sea pressure test is 90 days.
2-4.2.7 a.	Unless it can be shown that the recording medium can withstand the conditions associated with deep sea immersion and that it is unlikely to be damaged as a consequence of collapse of any protective armour, immerse the recorder in sea water at a pressure of 60 MPa (equivalent to a depth of 6 000 m (20 000 feet) for a period of 30 days. This period may be reduced to 24 hours provided that the methods and materials used to protect the recording medium have been shown to be unaffected by sea water. To avoid damage to the test equipment, this test may be performed using any suitable liquid in the pressure chamber itself together with a means to separate this liquid from the sea water in which the recorder is immersed.	Unless it can be shown that the recording medium can withstand the conditions associated with deep-sea immersion and that it is unlikely to be damaged as a consequence of collapse of any protective armour or except if the recorder is deployed during or following impact with water, immerse the recorder in seawater at a pressure of 60 MPa (equivalent to a depth of 6 000 m, i.e. 20 000 feet) for a period of 90 days. This period may be reduced to 24 hours provided that the test is performed once after the sea water immersion test in 2-4.2.7 b. To avoid damage to the test equipment, this test may be performed using any suitable liquid in the pressure chamber itself, together with a means to separate this liquid from the seawater in which the recorder is immersed.
2-4.2.7 b.	Unless it can be shown that the recording medium and the identification required by paragraph 2-1.16.3 are resistant to the corrosive effects of sea water, immerse the recorder in sea water at a depth of 3 m and nominal	Unless it can be shown that the recording medium and the identification required by paragraph 2-1.16.3 are resistant to the corrosive effects of seawater, immerse the recorder in seawater at a depth of 3 m and a temperature of at least + 25.0 °C for a period of 90 days.

Location	Initial ED-112A text	Amending text
	temperature of +25°C for a period of 30 days.	

[Amdt ETSO/16]

ETSO-2C177a

ED Decision 2020/011/R (applicable from 25.7.2020)

DATA LINK RECORDER EQUIPMENT

1 Applicability

This ETSO provides the requirements that new models of data link recorder systems that are designed and manufactured on or after the date of this ETSO must meet in order to be identified with the applicable ETSO marking.

2 Procedures

2.1 General

The applicable procedures are detailed in CS-ETSO, [Subpart A](#).

2.2 Specific

All the information specified in EUROCAE ED-112A, Section 2-1, 2-1.3.4, excluding item 6, shall be documented in a manual and be made available to the accident investigation authorities on request. In addition, if special tools or recovery techniques are used to retrieve recorded information from any memory device used within the crash-protected memory module removed from a crash-damaged recorder, these tools/recovery techniques shall be also made available to the accident investigation authorities on request.

Note: Requests from accident investigation authorities can be independent of any ongoing investigation.

3 Technical Conditions

3.1 Basic

3.1.1 Minimum Performance Standard

The applicable standards are those provided in the applicable sections of EUROCAE document ED-112A ‘Minimum Operational Performance Specification for Crash Protected Airborne Recorder Systems’ dated September 2013 that pertain to the types of data link recorder as defined in Table 1 below, except for the following exclusions: Chapters IV-1 and IV-6, and Sections 2-1.1, 2-1.5, 2-1.6, 2-1.11, 2-1.12, 2-3.1, 2-5, 3 and Annex IV-B and other ED-112A requirements related to aircraft-level equipment installation, flight testing and aircraft maintenance and as amended by Appendix 1 to this ETSO.

Recorder Type	ED-112A Reference
Single DLR in a non-deployable recorder	Section 2 and Part IV.
DLR function in a deployable recorder	Section 2 (except for the tests covered by ETSO-2C517) and Part IV. The recorder shall also comply with ETSO-2C517.
DLR function in a combined non-deployable recorder	Section 2, Section 4 and Part IV.
CVR function in a combined deployable recorder	Section 2 (except for the tests covered by ETSO-2C517), Section 4 and Part I. The recorder shall also comply with ETSO-2C517.

Table 1 — MPS Requirements per recorder type**3.1.2 Environmental Standard**

See CS-ETSO, [Subpart A](#), paragraph 2.1

3.1.3 Software

See CS-ETSO, [Subpart A](#), paragraph 2.2

3.1.4 Airborne Electronic Hardware

See CS-ETSO, [Subpart A](#), paragraph 2.3

3.2 Specific**3.2.1 Failure Condition Classification**

See CS-ETSO, [Subpart A](#), paragraph 2.4.

A loss or erroneous behaviour of the function defined in paragraph 3.1.1 of this ETSO has been determined to be a minor failure condition.

Note: The failure classification is driven by the use of recorders in accident investigations.

4 Marking**4.1 General**

See CS-ETSO, [Subpart A](#), paragraph 1.2

4.2 Specific

The equipment shall comply with the identification requirement in EUROCAE ED-112A Section 2-1, paragraph 2-1.16.3, if it is fixed, and those of ETSO-2C517, if it is deployable.

5 Availability of Referenced Documents

See CS-ETSO, [Subpart A](#), paragraph 3

[Amdt ETSO/6]

[Amdt ETSO/12]

[Amdt ETSO/16]

Appendix 1 to ETSO-C2177a – MPS for Crash-Protected Airborne Recorder Systems

ED Decision 2020/011/R

The standard EUROCAE ED-112A, MOPS for Crash Protected Airborne Recorder Systems, dated September 2013, shall be modified as per Table 1 below.

Table 1 — Modification of EUROCAE ED-112A

Location	Initial ED-112A text	Amending text
2-1.16.2 a. iii.	Impact shock, shear and tensile test, penetration resistance, static crush, deep sea pressure and sea water immersion.	Impact shock, shear and tensile test, penetration resistance, static crush, deep sea pressure and sea water immersion. Deep sea pressure and sea water immersion may be performed on two different units provided that both units undergo the rest of the sequence and that the period of the deep sea pressure test is 90 days.
2-4.2.7 a.	<p>Unless it can be shown that the recording medium can withstand the conditions associated with deep sea immersion and that it is unlikely to be damaged as a consequence of collapse of any protective armour, immerse the recorder in sea water at a pressure of 60 MPa (equivalent to a depth of 6 000 m (20 000 feet) for a period of 30 days.</p> <p>This period may be reduced to 24 hours provided that the methods and materials used to protect the recording medium have been shown to be unaffected by sea water. To avoid damage to the test equipment, this test may be performed using any suitable liquid in the pressure chamber itself together with a means to separate this liquid from the sea water in which the recorder is immersed.</p>	<p>Unless it can be shown that the recording medium can withstand the conditions associated with deep-sea immersion and that it is unlikely to be damaged as a consequence of collapse of any protective armour or except if the recorder is deployed during or following impact with water, immerse the recorder in seawater at a pressure of 60 MPa (equivalent to a depth of 6 000 m, i.e. 20 000 ft) for a period of 90 days.</p> <p>This period may be reduced to 24 hours provided that the test is performed once more after the sea water immersion test in 2-4.2.7 b. To avoid damage to the test equipment, this test may be performed using any suitable liquid in the pressure chamber itself together with a means to separate this liquid from the seawater in which the recorder is immersed.</p>
2-4.2.7 b.	Unless it can be shown that the recording medium and the identification required by paragraph 2-1.16.3 are resistant to the corrosive effects of sea water,	Unless it can be shown that the recording medium and the identification required by paragraph 2-1.16.3 are resistant to the corrosive effects of seawater, immerse the recorder in seawater at a depth of

Location	Initial ED-112A text	Amending text
	immerse the recorder in sea water at a depth of 3 m and nominal temperature of +25°C for a period of 30 days.	3 m and a temperature of at least + 25.0 °C for a period of 90 days.

[Amdt ETSO/16]

ETSO-2C197 A1

ED Decision 2020/011/R (applicable from 25.7.2020)

INFORMATION COLLECTION AND MONITORING SYSTEMS

1 Applicability

This ETSO provides the requirements which information collection and monitoring systems (ICMSs) that record cockpit audio, aircraft data, airborne images, or data link communications and that are designed and manufactured on or after the date of this ETSO must meet in order to be identified with the applicable ETSO marking.

2 Procedures

2.1 General

The applicable procedures are detailed in CS-ETSO, [Subpart A](#).

2.2 Specific

All the documents specified in EUROCAE ED-155, Section 2-1, 2-1.3.4, must be provided. In addition, a statement must be provided that tools are readily available for the retrieval of recorded information from any memory device used within the robust memory module removed from a crash damaged recorder.

Note: The documents and tools/special recovery techniques required above are meant to be offered to any safety investigation authority, whether or not the request from that authority is made in the frame of an ongoing investigation.

3 Technical Conditions

3.1 Basic

3.1.1 Minimum Performance Standard

The applicable standards are those provided in EUROCAE ED-155, Minimum Operational Performance Specification for Lightweight Flight Recording Systems, dated July 2009.

All ICMSs must meet the requirements in ED-155 Chapters 2-1, 2-2, 2-3 and 2-4 of Section 2. All deployable ICMS must also meet the requirements in ED-155 Chapters 3-1, 3-2, 3-3 and 3-4 of Section 3. Additionally, each Type of ICMS must meet the requirements of ED-155 listed in the table below.

ICMS Type	Your design must also meet the following requirements in ED-155	Your design does not need to meet the following requirements in ED-155
I	Part I, Cockpit Audio Recording System	I-2.1.7 and I-6
II	Part II, Aircraft Data Recording System	II-2.1.7, II-2.1.9, II-2.1.12, and II-6
III	Part III, Airborne Image Recording System	III-2.2 and III-6
IV	Part IV, Data-link Recording System	IV-2.1.6, IV-2.1.11, and IV-6

3.1.2 Environmental Standard

See CS-ETSO, [Subpart A](#), paragraph 2.1.

3.1.3 Software

See CS-ETSO, [Subpart A](#), paragraph 2.2.

3.1.4 Airborne Electronic Hardware

See CS-ETSO, [Subpart A](#), paragraph 2.3.

3.2 Specific

3.2.1 Minimum Dimensions for the Memory Module

The height (a), width (b), and depth (c) of the crash enclosure must each be 4 cm (1.5 inches) or greater.

3.2.2 Failure Condition Classification

See CS-ETSO, [Subpart A](#), paragraph 2.4

A failure of the function defined in paragraph 3.1.1 of this ETSO has been determined to be a minor failure condition. A loss of the function defined in paragraph 3.1.1 of this ETSO has been determined to be a minor failure condition.

Note: The failure classification is driven by the use of the recorders in accident investigations.

4 Marking

4.1 General

See CS-ETSO, [Subpart A](#), paragraph 1.2.

4.2 Specific

None.

5 Availability of Referenced Documents

See CS-ETSO, [Subpart A](#), paragraph 3.

[Amdt ETSO/7]

[Amdt ETSO/16]

ETSO-2C204a*ED Decision 2020/011/R (applicable from 25.7.2020)***CIRCUIT CARD ASSEMBLY (CCA) FUNCTIONAL SENSORS USING SATELLITE-BASED AUGMENTATION SYSTEMS (SBASS) FOR NAVIGATION AND NON-NAVIGATION POSITION/VELOCITY/TIME (PVT) OUTPUT****1 Applicability**

This ETSO provides the requirements that circuit card assembly (CCA) functional sensors that use satellite-based augmentation systems (SBASs) for navigation and non-navigation position/velocity/time (PVT) output, which are designed and manufactured on or after the date of this ETSO, must meet in order to be identified with the applicable ETSO marking.

ETSO-2C204a is intended as a means for manufacturers of end-use equipment to rationalise their ETSO-C145e applications for Class Beta PVT sensors by using ETSO-authorized SBAS CCAs for partial certification credit.

An ETSO-2C204a article has a limitation that requires the manufacturer of end-use equipment to repeat selected detailed functional tests in the end-use equipment and complete the environmental qualification tests in RTCA document DO-229E (see paragraphs 3.1.2.2 and 3.2.2 below).

2 Procedures**2.1 General**

The applicable procedures are detailed in CS-ETSO, Subpart A.

2.2 Specific

None.

3 Technical Conditions**3.1 Basic****3.1.1 Minimum Performance Standard**

The applicable standards are those provided for Class Beta functional equipment in RTCA document DO-229E, Minimum Operational Performance Standards for Global Positioning System/Satellite-Based Augmentation System Airborne Equipment, dated 15 December 2016, Section 2, as amended by Appendices 1 and 3 to this ETSO.

Class Beta equipment is defined in RTCA document DO-229E, Section 1.4.

The standards in this ETSO apply to CCAs that are intended to provide PVT information for navigation management unit applications that output deviation commands keyed to a desired flight path, or non-navigation applications such as automatic dependent surveillance — broadcast (ADS-B) or terrain awareness and warning systems (TAWS). In navigation applications, pilots or autopilots will use the deviations output by the navigation management unit to guide the aircraft. In non-navigation applications, the PVT outputs will provide the necessary inputs for the end-use equipment.

3.1.2 Environmental Testing and Test Procedures

3.1.2.1 Environmental Testing

For the applicable environmental standards, see CS-ETSO, Subpart A, paragraph 2.1.

Nevertheless, not all types of environmental test are required for this ETSO standard, as the ETSO article for this ETSO standard is a CCA that will be later integrated into an item of ETSO equipment. Therefore, a minimal set of the environmental test conditions of EUROCAE ED-14/RTCA document DO-160 has been defined (refer to Table 1) in order to verify the performance of the ETSOA article under this minimal set of conditions. The required performance under a particular environmental test is defined in the related test section in RTCA document DO-229E, Minimum Operational Performance Standards for Global Positioning System/Satellite-Based Augmentation System Airborne Equipment, dated 15 December 2016, Section 2.4.

This minimal set is defined in Table 1 below. The chosen test category, associated with the selectable parameters in the test conditions per EUROCAE ED-14/RTCA document DO-160, should be documented in the installation manual as limitations for the installation.

The test sections that are identified as optional are not required for an ETSO-2C204a application. Nevertheless, the ETSO CCA article can be subjected to these test conditions by the applicant on a voluntary basis. If optional sections are not tested, they shall be marked with 'X' in the environmental testing summary.

Table 1 — Environmental Qualification Testing minimum set for ETSO-2C204a

Environmental Test	EUROCAE ED-14/RTCA DO-160 Section	Requirement for ETSO-2C204a
Temperature	4.5	<p>Mandatory</p> <p>If the performance of the module under environmental conditions is dependent on the end-user equipment, it is the responsibility of the applicant to adapt the EUROCAE ED-14/RTCA DO-160 high and low operating temperature values and temperature variation cycles to the intended installation context.</p> <p>For example, in the case of temperature testing (Section 4.0 of EUROCAE ED-14/RTCA DO-160), the temperature of the environment of the CCA (inside an item of equipment) may be much higher or lower than the equipment level condition expressed in the aforementioned Section 4.0. Therefore,</p>

Environmental Test	EUROCAE ED-14/RTCA DO-160 Section	Requirement for ETSO-2C204a
		<p>the applicant may qualify their CCA functional sensor based on a chosen intended environment, and, finally, indicate in the installation manual the temperature range for which the correct operation of the CCA is guaranteed.</p> <p>The dissipation constraints required for the CCA and documented in the installation manual should be considered when establishing the temperature test set-up.</p>
Altitude	4.6	Mandatory
Temperature Variation	5.0	<p>Mandatory</p> <p>As for Section 4.5, if the performance of the CCA under environmental conditions is dependent on the end-user equipment, it is the responsibility of the applicant to adapt the EUROCAE ED-14/RTCA DO-160 high and low temperature values and temperature variation cycles to the intended CCA installation context.</p> <p>As for Section 4.5, for example, in the case of temperature testing (Section 4.0 of EUROCAE ED-14/RTCA DO-160), in which the temperature of the environment of the CCA (inside an item of equipment) may be much higher or lower than the equipment level condition as expressed in Section 4.0 of EUROCAE ED-14/RTCA DO-160, the applicant can qualify their CCA based on a chosen intended environment, and, finally, indicate in the installation manual the temperature range for which the correct operation of the CCA functional sensor is guaranteed.</p>
Humidity	6.0	Mandatory
Shock (operational)	7.2	Optional
Shock (Crash Safety)	7.3	Optional
Vibration	8.0	<p>Optional</p> <p>Note: The CCA <u>technology</u> should be assessed for further vibration qualification (EUROCAE ED-14/RTCA DO-160). This preliminary assessment could consider the technology diversity of the components of the CCA, as well as the integration density and number of layers of the circuit card. The assessment could be confirmed by tests conducted on</p>

Environmental Test	EUROCAE ED-14/RTCA DO-160 Section	Requirement for ETSO-2C204a
		a circuit card that is representative of the CCA <u>technology</u> used in the article under certification. This preliminary assessment of the CCA technology under vibration conditions does not constitute credit for the qualification testing of the CCA when it is integrated into the end-user equipment.
Explosion Atmosphere	9.0	Optional
Waterproof	10.0	Optional
Fluids Susceptibility	11.0	Optional
Sand and Dust	12.0	Optional
Fungus Resistance	13.0	Optional
Salt Fog	14.0	Optional
Magnetic Effect	15.0	Optional
Power Input	16.0	Mandatory for CCA interfaces that are directly connected to the aircraft power distribution system.
Voltage Spike	17.0	Mandatory for CCA interfaces that are directly connected to the aircraft power distribution system. Note: CCA interfaces that are not directly connected to the aircraft power distribution system will be tested after the integration phase as part of the end-user ETSO application or as part of a type-certification programme.
Audio Frequency Conducted Susceptibility — Power Input	18.0	Mandatory for CCA interfaces that are directly connected to the aircraft power distribution system. Note: CCA interfaces that are not directly connected to the aircraft power distribution system will be tested after the integration phase as part of the end-user ETSO application or as part of a type-certification programme.
Induced-Signal Susceptibility	19.0	Mandatory for CCA interfaces that are directly connected to the aircraft wiring. Note: CCA interfaces that are not directly connected to the aircraft wiring will be tested after the integration phase as

Environmental Test	EUROCAE ED-14/RTCA DO-160 Section	Requirement for ETSO-2C204a
		part of the end-user ETSO application or as part of a type-certification programme.
Radio Frequency Susceptibility (radiated and conducted)	20.0	Mandatory for the conducted susceptibility of CCA interfaces that are directly connected to the aircraft wiring. Note: CCA interfaces that are not directly connected to the aircraft wiring will be tested after the integration phase as part of the end-user ETSO application or as part of a type-certification programme.
Emission of Radio Frequency Energy	21.0	Mandatory for the conducted emission of CCA interfaces that are directly connected to the aircraft wiring. Note: CCA interfaces that are not directly connected to the aircraft wiring will be tested after the integration phase as part of the end-user ETSO application or as part of a type-certification programme.
Lightning-Induced Transient Susceptibility	22.0	Mandatory for CCA interfaces that are directly connected to the aircraft wiring. Note: CCA interfaces that are not directly connected to the aircraft wiring will be tested after the integration phase as part of the end-user ETSO application or as part of a type-certification programme.
Lightning Direct Effects	23.0	Optional
Icing	24.0	Optional
Electrostatic Discharge (ESD)	25.0	Optional
Fire, Flammability	26.0	Mandatory for flammability (ED-14/DO-160 Section 26, Category C)

3.1.2.2 Environmental Test Procedures for End User

The end user of this ETSO article will be required to complete the environmental qualification testing after integration of the ETSO-2C204a CCA. In order to allow the end user to properly test the functionality of the SBAS CCA functional sensor in environmental conditions, the applicant for the 'SBAS CCA functional sensor' shall provide the detailed functional test procedures to evaluate the required performance of the SBAS CCA functional sensor in

compliance with RTCA document DO-229E, Minimum Operational Performance Standards for Global Positioning System/Satellite-Based Augmentation System Airborne Equipment, dated 15 December 2016, Section 2.4.

3.1.3 Software

See CS-ETSO, Subpart A, paragraph 2.2.

3.1.4 Airborne Electronic Hardware

See CS-ETSO, Subpart A, paragraph 2.3.

3.2 Specific

3.2.1 Failure Condition Classification

See CS-ETSO, Subpart A, paragraph 2.4.

A failure of the function defined in paragraph 3.1.1 of this ETSO is a:

- major failure condition for a loss of function and malfunction of en route, terminal, approach lateral navigation (LNAV), and approach LNAV/vertical navigation (VNAV) position data;
- major failure condition for a loss of function of approach localiser performance without vertical guidance (LP), and approach localiser performance with vertical guidance (LPV) position data; and
- hazardous failure condition for a malfunction of approach (LP and LPV) position data that results in misleading information.

3.2.2 Additional Specific

If the SBAS CCA functional sensor can only satisfy the requirements of RTCA document DO-229E when used with a particular antenna, the use of that antenna (by part number) shall be a requirement on the installation.

This requirement shall be included in the installation manual as a limitation.

The applicant shall have all the data necessary to evaluate the geostationary (GEO) satellite bias as defined in RTCA document DO-229E, Section 2.1.4.1.5, available for review by EASA.

If the SBAS CCA functional sensor uses barometric-aiding to enhance the availability of FDE, then the equipment shall meet the requirements in RTCA document DO-229E, Appendix G.

The applicant shall provide to the end user the detailed functional test procedures of the SBAS CCA functional sensor for the end user to complete the environmental testing.

The intended installation environment and the associated installation constraints should be documented in the installation manual.

Limitations

The following specific limitations shall be documented in the installation manual and in the declaration of design and performance (DDP) of the SBAS CCA functional sensor:

- ‘The manufacturer of the end-use equipment, who installs the <insert

equipment model> SBAS CCA functional sensor, is required to perform the testing described in ETSO-C145<latest revision> Appendix 1 with the SBAS CCA functional sensor installed in the end-use equipment.'

- 'The manufacturer of end-use equipment is required to complete full environmental qualification at the end-use equipment level.'

4 Marking

4.1 General

See CS-ETSO, Subpart A, paragraph 1.2.

4.2 Specific

The SBAS CCA functional sensor must be permanently and legibly marked with the operational equipment class (e.g. Class 2), as defined in Section 1.4.2 of RTCA document DO-229E. The functional equipment class (e.g. Beta) defined in Section 1.4.1 of RTCA document DO-229E is not required to be marked.

It is sufficient to declare the proper functional equipment class in the DDP.

5 Availability of Referenced Documents

See CS-ETSO, Subpart A, paragraph 3.

[Amdt ETSO/16]

Appendix 1 to ETSO-2C204a – Addition to RTCA Document DO-229E

ED Decision 2020/011/R

This Appendix describes the modifications and additions to RTCA DO-229E that are required for compliance with this ETSO.

This Appendix adds a new Section 1.8.3, on cybersecurity and GNSS spoofing mitigation, to RTCA document DO-229E, and corrects a long-standing mistake in the Section 2.4 environmental requirements tables. The new section provides information for cybersecurity and GNSS spoofing mitigation to make RTCA document DO-229E consistent with the new RTCA MOPS template and RTCA document DO-253D, Minimum Operational Performance Standards for GPS Local Area Augmentation System Airborne Equipment, dated July 2017.

1.8.3 Cybersecurity and GNSS Spoofing Mitigation.

This section contains information to address intentional interference with the GNSS. Spoofing is caused by RF waveforms that mimic true signals in some ways, but deny, degrade, disrupt, or deceive the operation of a receiver when they are processed. Spoofing may be unintentional, such as effects from the signals of a GNSS repeater, or may be intentional and even malicious. There are two classes of spoofing:

- Measurement spoofing introduces RF waveforms that cause the target receiver to produce incorrect measurements of the time of arrival or the frequency of arrival, or their rates of change;
- Data spoofing introduces incorrect digital data to the target receiver for its use in the processing of signals and the calculation of positioning, navigation and timing (PNT).

Either class of spoofing can cause a range of effects: from incorrect outputs of PNT to receiver malfunctions. The onset of effects can be instantaneous or delayed, and the effects can continue even after the spoofing has ended. Improperly used or improperly installed GNSS re-radiators act like spoofers. Re-radiators, replay and GNSS emulator devices can present misleading information to GNSS equipment and/or could cause lasting effects.

Equipment manufacturers should implement measures to mitigate the processing of erroneous data. Cross-checks of GNSS sensor data against independent position sources and/or other detection monitors using GNSS signal metrics or data checks can be implemented in the antenna, receiver, and/or through integration with other systems at the aircraft level. Data validity checks to recognise and reject measurement and data spoofing should be implemented in the receiver. Additional guidance and best practices related to GPS equipment can be found in the U.S. Department of Homeland Security document ‘Improving the Operation and Development of Global Positioning System (GPS) Equipment Used by Critical Infrastructure’¹ and GLOBAL POSITIONING SYSTEMS DIRECTORATE SYSTEMS ENGINEERING & INTEGRATION: INTERFACE SPECIFICATION, IS-GPS-200, Navstar GPS Space Segment/Navigation User Interfaces, Revision H, IRN-IS-200H-003, 28 July 2016.

Aircraft equipment information vulnerabilities (such as cybersecurity risks) have been present for digital systems since the development of the personal computer (PC) in the late 1970s and even longer for RF systems, and the advent of internet connectivity has substantially increased those risks. Typically, access to navigation receivers has been controlled such that they are considered to be

¹ [https://ics-cert.us-ert.gov/sites/default/files/documents/Improving_the_Operation_and_Development_of_Global_Positioning_System_\(GPS\)_Equipment_Used_by_Critical_Infrastructure_S508C.pdf](https://ics-cert.us-ert.gov/sites/default/files/documents/Improving_the_Operation_and_Development_of_Global_Positioning_System_(GPS)_Equipment_Used_by_Critical_Infrastructure_S508C.pdf)

vulnerable only to RF signals and OEM and/or aircraft operator controlled processes for maintenance and update. In some cases, aircraft GNSS receivers may be field-loadable by approved personnel, requiring physical access and a physical interface to the ground receivers. However, it is expected that not all aircraft in the future will rely on such physical isolation for the security of avionics. Internet and Wi-Fi connectivity have become popular as means for aircraft or equipment manufacturers to update the software of installed avionics, to update databases, or provide an alternate means of communicating with the flight crew or cabin (e.g. in-flight entertainment, weather, etc.).

In most countries, the State provides oversight of safety-of-flight systems (sometimes referred to as ‘authorised services’) which provide information to aircraft, such as ILS, VOR, GNSS and DME, to name a few. However, the State typically does not provide oversight of ‘non-trusted’ connectivity such as the internet, Wi-Fi, or manufacturer-supplied equipment interfaces which permit the input of externally supplied data into aircraft systems. A manufacturer may expose aircraft information vulnerabilities through the design of the equipment, or the equipment may become vulnerable as a result of being connected to a common interface. Therefore, it is important for manufacturers to consider aircraft information security risk mitigation strategies in their equipment design, particularly when the equipment is responsible for an interface between the aircraft and aircraft-external systems.

Apart from any specific aircraft-information-security-related performance requirements that are contained in the MOPS, it is recommended that manufacturers should consider a layered approach to aircraft information security risk mitigation that includes both technical (e.g. software, signal filtering) and physical strategies. From a technical perspective, for example, this could include signal spoofing detection capabilities or more stringent, multi-factored authentication techniques such as passwords, PINs, and digital certificates. And finally, but just as important, manufacturers should consider supply chain risk management; for example, if a manufacturer outsources the development of software code, are the contractor and its staff properly vetted?

Civil aviation authorities (CAAs) have a regulatory interest when an applicant’s design makes use of a non-trusted connection through which the installation can potentially introduce aircraft information security vulnerabilities. This requires the applicant to address not only the information security vulnerabilities and mitigation techniques for the new installation, but to also consider how vulnerabilities could propagate to existing downstream systems. Therefore, manufacturers are recommended to reference their equipment aircraft information security review and mitigation strategies in the installation manual of the equipment so that the applicant can consider them in meeting the regulatory requirements of the installation.

Table 2-14 to Table 2-20

The tables incorrectly reference and label RTCA document DO-160 Sections 16.5.1.2 and 16.6.1.2 regarding ‘2.1.1.7 Acquisition Time’ and ‘2.1.1.9 Reacquisition Time’. Change the table references as follows:

The MOPS initial acquisition time requirement (2.1.1.7) applies to both AC and DC equipment under abnormal operating conditions (DO-160E Sections 16.5.2 and 16.6.2) and the satellite reacquisition time requirement (2.1.1.9) applies to both AC and DC equipment under normal operating conditions (DO-160E Sections 16.5.1 and 16.6.1).

[Amdt ETSO/16]

Appendix 2 to ETSO-2C204a – Addition to RTCA Document DO-229E

ED Decision 2020/011/R

Reserved.

[Amdt ETSO/16]

Appendix 3 to ETSO-2C204a

ED Decision 2020/011/R

This Appendix describes the EASA modifications to RTCA document DO-229E, Section 2.

In Section 2.1.1.2, after the first sentence, add the following:

‘The demodulation of data from the GPS signals shall be restricted to the necessary subset of the data defined in Appendix II to IS-GPS-200D, “Navstar GPS Space Segment/Navigation User Interfaces”, December 2004, provided on RF link L1. The pseudo-ranging shall be performed on RF link L1 utilising the coarse/acquisition (C/A) code.’

This is to ensure that only the L1 NAV data, for which the SBAS provides corrections and integrity, is used, and that no CNAV data, which is defined in Appendix III to IS-GPS-200D, is used, for which the SBAS does not provide integrity.

[Amdt ETSO/16]

ETSO-2C205a*ED Decision 2020/011/R (applicable from 25.7.2020)***CIRCUIT CARD ASSEMBLY (CCA) FUNCTIONAL CLASS DELTA EQUIPMENT USING THE SATELLITE-BASED AUGMENTATION SYSTEMS (SBAS) FOR NAVIGATION APPLICATIONS****1 Applicability**

This ETSO provides the requirements which circuit card assembly (CCA) functional Class Delta-4 equipment using the satellite-based augmentation system (SBAS) for navigation applications, that are designed and manufactured on or after the date of this ETSO, must meet in order to be identified with the applicable ETSO marking.

ETSO-2C205a is intended as a means for manufacturers of end-use equipment to rationalise their ETSO-C146e application for a Class Delta-4 sensor by using an ETSO Delta-4 CCA for partial certification credit. ETSO-2C205a is only intended for navigation applications; it is not intended for non-navigation applications.

The standards in this ETSO apply to equipment that is intended to accept a desired flight path and provide deviation commands that are keyed to that path. Pilots and autopilots will use these deviations to guide the aircraft.

An ETSO-2C205a article has a limitation that requires the end-use equipment manufacturer to repeat selected detailed functional tests in the end-use equipment and complete the environmental qualification tests in RTCA document DO-229E (see paragraphs 3.2.2.1 and 3.2.2 below).

2 Procedures**2.1 General**

The applicable procedures are detailed in CS-ETSO, Subpart A.

2.2 Specific

None.

3 Technical Conditions**3.1 Basic****3.1.1 Minimum Performance Standard**

The applicable standards are those provided for functional Class Delta-4 equipment in RTCA document DO-229E, Minimum Operational Performance Standards for Global Positioning System/Satellite-Based Augmentation System Airborne Equipment, dated 15 December 2016, Section 2, as amended by Appendices 1 and 3 to this ETSO standard. Class Delta-4 equipment is defined in DO-229E, Section 1.4.

3.1.2 Environmental Testing and Test Procedures**3.1.2.1 Environmental Testing**

For the applicable environmental standards, see CS-ETSO, Subpart A, paragraph 2.1.

Nevertheless, not all types of environmental test are required for this ETSO standard, as the ETSO article for this ETSO standard is a CCA that will be later integrated into an item of ETSO equipment.

Therefore, a minimal set of the environmental test conditions of EUROCAE ED-14/RTCA document DO-160 has been defined (refer to Table 1) in order to verify the performance of the ETSOA article under this minimal set of conditions. The required performance under a particular environmental test is defined in the related test section in RTCA document DO-229E, Minimum Operational Performance Standards for Global Positioning System/Satellite-Based Augmentation System Airborne Equipment, dated 15 December 2016, Section 2.4.

This minimal set is defined in Table 1 below. The chosen test category, associated with the selectable parameters in the test conditions per EUROCAE ED-14/RTCA document DO-160, should be documented in the installation manual as limitations for the installation.

The test sections that are identified as optional are not required for an ETSO-2C205a application. Nevertheless, the ETSO CCA article can be subjected to these test conditions by the applicant on a voluntary basis. When optional sections are not tested, they shall be marked with 'X' in the environmental testing summary.

Table 1 — Environmental Qualification Testing minimum set for ETSO-2C205a

Environmental Test	EUROCAE ED-14/RTCA DO-160 Section	Requirement for ETSO-2C205a
Temperature	4.5	<p>Mandatory</p> <p>If the performance of the module under environmental conditions is dependent on the end-user equipment, it is the responsibility of the applicant to adapt the EUROCAE ED-14/RTCA DO-160 high and low temperature values and temperature variation cycles to the intended installation context.</p> <p>For example, in the case of temperature testing (Section 4.0 of EUROCAE ED-14/RTCA DO-160), the temperature of the environment of the CCA (inside an item of equipment) may be much higher or lower than the equipment level condition expressed in the aforementioned Section 4.0. Therefore, the applicant may qualify their CCA functional sensor based on a chosen intended environment, and, finally, indicate in the installation manual the temperature range for which the correct operation of the CCA is guaranteed.</p> <p>The dissipation constraints required for the CCA and documented in the installation manual should be considered when establishing the temperature test set-up.</p>

Environmental Test	EUROCAE ED-14/RTCA DO-160 Section	Requirement for ETSO-2C205a
Altitude	4.6	Mandatory
Temperature Variation	5.0	<p>Mandatory</p> <p>As for Section 4.5, if the performance of the CCA under environmental conditions is dependent on the end-user equipment, it is the responsibility of the applicant to adapt the EUROCAE ED-14/RTCA DO-160 high and low temperature values and temperature variation cycles to the intended CCA installation context.</p> <p>As for Section 4.5, for example, in the case of temperature testing (Section 4.0 of EUROCAE ED-14/RTCA DO-160), in which the temperature of the environment of the CCA (inside an item of equipment) may be much higher or lower than the equipment level condition as expressed in Section 4.0 of EUROCAE ED-14/RTCA DO-160, the applicant can qualify their CCA based on a chosen intended environment, and, finally, indicate in the installation manual the temperature range for which the correct operation of the CCA functional sensor is guaranteed.</p>
Humidity	6.0	Mandatory
Shock (operational)	7.2	Optional
Shock (Crash Safety)	7.3	Optional
Vibration	8.0	<p>Optional</p> <p>Note: The CCA <u>technology</u> should be assessed for further vibration qualification (EUROCAE ED-14/RTCA DO-160). This preliminary assessment could consider the technology diversity of the components of the CCA, as well as the integration density and number of layers of the circuit card. The assessment could be confirmed by tests conducted on a circuit card that is representative of the CCA <u>technology</u> used in the article under certification. This preliminary assessment of the CCA technology under vibration conditions does not constitute credit for the qualification testing of the CCA when it is integrated into the end-user equipment.</p>
Explosion Atmosphere	9.0	Optional
Waterproof	10.0	Optional

Environmental Test	EUROCAE ED-14/RTCA DO-160 Section	Requirement for ETSO-2C205a
Fluids Susceptibility	11.0	Optional
Sand and Dust	12.0	Optional
Fungus Resistance	13.0	Optional
Salt Fog	14.0	Optional
Magnetic Effect	15.0	Optional
Power Input	16.0	Mandatory for CCA interfaces that are directly connected to the aircraft power distribution system.
Voltage Spike	17.0	Mandatory for CCA interfaces that are directly connected to the aircraft power distribution system. Note: CCA interfaces that are not directly connected to the aircraft power distribution system will be tested after the integration phase as part of the end-user ETSO application or as part of a type-certification programme.
Audio Frequency Conducted Susceptibility — Power Input	18.0	Mandatory for CCA interfaces that are directly connected to the aircraft power distribution system. Note: CCA interfaces that are not directly connected to the aircraft power distribution system will be tested after the integration phase as part of the end-user ETSO application or as part of a type-certification programme.
Induced-Signal Susceptibility	19.0	Mandatory for CCA interfaces that are directly connected to the aircraft wiring. Note: CCA interfaces that are not directly connected to the aircraft wiring will be tested after the integration phase as part of the end-user ETSO application or as part of a type-certification programme.
Radio Frequency Susceptibility (radiated and conducted)	20.0	Mandatory for the conducted susceptibility of CCA interfaces that are directly connected to the aircraft wiring. Note: CCA interfaces that are not directly connected to the aircraft wiring will be tested after the integration phase as part of the end-user ETSO application or as part of a type-certification programme.
Emission of Radio Frequency Energy	21.0	Mandatory for the conducted emission of CCA interfaces that are directly connected to the aircraft wiring.

Environmental Test	EUROCAE ED-14/RTCA DO-160 Section	Requirement for ETSO-2C205a
		Note: CCA interfaces that are not directly connected to the aircraft wiring will be tested after the integration phase as part of the end-user ETSO application or as part of a type-certification programme.
Lightning-Induced Transient Susceptibility	22.0	Mandatory for CCA interfaces that are directly connected to the aircraft wiring. Note: CCA interfaces that are not directly connected to the aircraft wiring will be tested after the integration phase as part of the end-user ETSO application or as part of a type-certification programme.
Lightning Direct Effects	23.0	Optional
Icing	24.0	Optional
Electrostatic Discharge (ESD)	25.0	Optional
Fire, Flammability	26.0	Mandatory for flammability (ED-14/DO-160 Section 26, Category C).

3.1.2.2 Environmental Test Procedures for End User

The end user of this ETSO article will be required to verify its performance after integration, and complete the environmental qualification testing after integration of the ETSO-2C205a CCA. In order to allow the end user to properly test the functionality of the CCA functional Class Delta equipment in environmental conditions, the applicant for the 'functional Class Delta ETSO article' shall provide the detailed functional test procedures to evaluate the required performance of the functional Class Delta equipment in compliance with RTCA document DO-229E, Minimum Operational Performance Standards for Global Positioning System/Satellite-Based Augmentation System Airborne Equipment, dated 15 December 2016, Section 2.4.

3.1.3 Software

See CS-ETSO, Subpart A, paragraph 2.2.

3.1.4 Airborne Electronic Hardware

See CS-ETSO, Subpart A, paragraph 2.3.

3.2 Specific

3.2.1 Failure Condition Classification

See CS-ETSO, Subpart A, paragraph 2.4.

A failure of the function defined in paragraph 3.1.1 of this ETSO is a:

- major failure condition for a loss of function and malfunction of en route, terminal, approach lateral navigation (LNAV), and approach LNAV/vertical navigation (VNAV) position data;
- major failure condition for a loss of function of approach localiser performance without vertical guidance (LP), and approach localiser performance with vertical guidance (LPV) position data; and
- hazardous failure condition for a malfunction of approach (LP and LPV) position data that results in misleading information.

3.2.2 Additional Specific

If the CCA functional Class Delta equipment can satisfy the requirements of RTCA document DO-229E only when used with a particular antenna, the use of that antenna (by part number) shall be a requirement on the installation.

This requirement shall be included in the installation manual as a limitation.

The applicant shall have all the data necessary to evaluate the geostationary (GEO) satellite bias as defined in RTCA document DO-229E, Section 2.1.4.1.5, available for review by EASA.

If the functional Class Delta equipment uses barometric-aiding to enhance the availability of FDE, then the equipment shall meet the requirements in RTCA document DO-229E, Appendix G.

The applicant shall provide to the end user the detailed functional test procedures of the functional Class Delta equipment for the end user to complete the environmental testing.

The intended installation environment and the associated installation constraints should be documented in the installation Manual.

Limitations:

The following specific limitations shall be documented in the IM and in the DDP of the CCA functional Class Delta equipment :

- ‘The manufacturer of the end-use equipment, using the <insert equipment model> Class Delta CCA, is required to perform the testing described in ETSO-C146<latest revision> Appendix 1 with the Class Delta CCA installed in the end-use equipment.’
- ‘the manufacturer of end-use equipment is required to complete full environmental qualification at the end-use equipment level.’

4 Marking

4.1 General

See CS-ETSO, Subpart A, paragraph 1.2.

4.2 Specific

The functional Class Delta equipment must be permanently and legibly marked with the operational equipment class (e.g. Class 4) as defined in Section 1.4.2 of RTCA document DO-229E. A marking of Class 4 indicates compliance with the Delta-4 requirements. The functional equipment class (e.g. Delta) defined in Section 1.4.1 of RTCA document DO-229E is not required to be marked.

It is sufficient to declare the proper functional equipment class in the declaration of design and performance (DDP).

5 Availability of Referenced Documents

See CS-ETSO, Subpart A, paragraph 3.

[Amdt ETSO/16]

Appendix 1 – Addition to RTCA DO-229E

ED Decision 2020/011/R

This Appendix describes the modifications and additions to RTCA document DO-229E that are required for compliance with this ETSO.

This Appendix adds a new Section 1.8.3, on cybersecurity and GNSS spoofing mitigation, to RTCA document DO-229E, and corrects a long-standing mistake in the Section 2.4 environmental requirement tables. The new section provides information for cybersecurity and GNSS spoofing mitigation to make RTCA document DO-229E consistent with the new RTCA MOPS template and RTCA document DO-253D, Minimum Operational Performance Standards for GPS Local Area Augmentation System Airborne Equipment, dated July 2017.

1.8.3 Cybersecurity and GNSS Spoofing Mitigation

This section contains information to address intentional interference with the GNSS. Spoofing is caused by RF waveforms that mimic true signals in some ways, but deny, degrade, disrupt, or deceive the operation of a receiver when they are processed. Spoofing may be unintentional, such as effects from the signals of a GNSS repeater, or may be intentional and even malicious. There are two classes of spoofing:

- Measurement spoofing introduces RF waveforms that cause the target receiver to produce incorrect measurements of the time of arrival or the frequency of arrival, or their rates of change;
- Data spoofing introduces incorrect digital data to the target receiver for its use in the processing of signals and the calculation of positioning, navigation and timing (PNT).

Either class of spoofing can cause a range of effects: from incorrect outputs of PNT to receiver malfunctions. The onset of effects can be instantaneous or delayed, and the effects can continue even after the spoofing has ended. Improperly used or improperly installed GNSS re-radiators act like spoofers. Re-radiators, replay and GNSS emulator devices can present misleading information to GNSS equipment and/or could cause lasting effects.

Equipment manufacturers should implement measures to mitigate the processing of erroneous data. Cross-checks of GNSS sensor data against independent position sources and/or other detection monitors using GNSS signal metrics or data checks can be implemented in the antenna, receiver, and/or through integration with other systems at the aircraft level. Data validity checks to recognise and reject measurement and data spoofing should be implemented in the receiver. Additional guidance and best practices related to GNSS equipment can be found in the U.S. Department of Homeland Security document ‘Improving the Operation and Development of Global Positioning System (GPS) Equipment Used by Critical Infrastructure’¹ and GLOBAL POSITIONING SYSTEMS DIRECTORATE SYSTEMS ENGINEERING & INTEGRATION: INTERFACE SPECIFICATION, IS-GPS-200, Navstar GPS Space Segment/Navigation User Interfaces, Revision H, IRN-IS-200H-003, 28 July 2016.

Aircraft equipment information vulnerabilities (such as cybersecurity risks) have been present for digital systems since the development of the personal computer (PC) in the late 1970s and even longer for RF systems, and the advent of internet connectivity has substantially increased those risks. Typically, access to navigation receivers has been controlled such that they are considered to be

¹ [https://ics-cert.us-cert.gov/sites/default/files/documents/Improving_the_Operation_and_Development_of_Global_Positioning_System_\(GPS\)_Equipment_Used_by_Critical_Infrastructure_S508C.pdf](https://ics-cert.us-cert.gov/sites/default/files/documents/Improving_the_Operation_and_Development_of_Global_Positioning_System_(GPS)_Equipment_Used_by_Critical_Infrastructure_S508C.pdf)

vulnerable only to RF signals and OEM and/or aircraft operator controlled processes for maintenance and update. In some cases, aircraft GNSS receivers may be field-loadable by approved personnel, requiring physical access and a physical interface to the ground receivers. However, it is expected that not all aircraft in the future will rely on such physical isolation for the security of avionics. Internet and Wi-Fi connectivity have become popular as a means for aircraft or equipment manufacturers to update the software of installed avionics, to update databases, or provide an alternate means of communicating with the flight crew or cabin (e.g. in-flight entertainment, weather, etc.).

In most countries, the State provides oversight of safety-of-flight systems (sometimes referred to as ‘authorised services’) which provide information to aircraft, such as ILS, VOR, GNSS, and DME, to name a few. However, the State typically does not provide oversight of ‘non-trusted’ connectivity such as the internet, Wi-Fi, or manufacturer-supplied equipment interfaces which permit the input of externally supplied data into aircraft systems. A manufacturer may expose aircraft information vulnerabilities through the design of the equipment, or the equipment may become vulnerable as a result of being connected to a common interface. Therefore, it is important for manufacturers to consider aircraft information security risk mitigation strategies in their equipment design, particularly when the equipment is responsible for an interface between the aircraft and aircraft-external systems.

Apart from any specific aircraft-information-security-related performance requirements that are contained in the MOPS, manufacturers are recommended to consider a layered approach to aircraft information security risk mitigation that includes both technical (e.g. software, signal filtering) and physical strategies. From a technical perspective, for example, this could include signal spoofing detection capabilities or more stringent, multi-factored authentication techniques such as passwords, PINs, and digital certificates. And finally, but just as important, manufacturers should consider supply chain risk management; for example, if a manufacturer outsources the development of software code, are the contractor and its staff properly vetted?

Civil aviation authorities (CAAs) have a regulatory interest when an applicant’s design makes use of a non-trusted connection through which the installation can potentially introduce aircraft information security vulnerabilities. This requires the applicant to address not only the information security vulnerabilities and mitigation techniques for the new installation, but to also consider how vulnerabilities could propagate to existing downstream systems. Therefore, manufacturers are recommended to reference their equipment aircraft information security review and mitigation strategies in the installation manual of the equipment so that the applicant can consider them in meeting the regulatory requirements of the installation.

Table 2-14 through Table 2-20

The tables incorrectly reference and label RTCA document DO-160 Sections 16.5.1.2 and 16.6.1.2 regarding ‘2.1.1.7 Acquisition Time’ and ‘2.1.1.9 Reacquisition Time’. Change the table references as follows:

The MOPS Initial Acquisition Time requirement (2.1.1.7) applies to both AC and DC equipment under abnormal operating conditions (DO-160E Sections 16.5.2 and 16.6.2), and the satellite reacquisition time requirement (2.1.1.9) applies to both AC and DC equipment under normal operating conditions (DO-160E Sections 16.5.1 and 16.6.1).

[Amdt ETSO/16]

Appendix 2

ED Decision 2020/011/R

Reserved.

[Amdt ETSO/16]

Appendix 3

ED Decision 2020/011/R

This Appendix describes the EASA modifications to RTCA document DO-229E, Section 2.

In Section 2.1.1.2, after the first sentence, add the following:

‘The demodulation of data from the GPS signals shall be restricted to the necessary subset of the data defined in Appendix II to IS-GPS-200D, “Navstar GPS Space Segment/Navigation User Interfaces”, December 2004, provided on RF link L1. The pseudo-ranging shall be performed on RF link L1 utilising the coarse/acquisition (C/A) code.’

This is to ensure that only the L1 NAV data, for which the SBAS provides corrections and integrity, is used, and that no CNAV data, which is defined in Appendix III to IS-GPS-200D, is used, for which the SBAS does not provide integrity.

[Amdt ETSO/16]

ETSO-2C206*ED Decision 2020/011/R (applicable from 25.7.2020)***CIRCUIT CARD ASSEMBLY (CCA) FUNCTIONAL SENSORS USING THE AIRCRAFT-BASED AUGMENTATION FOR NAVIGATION AND NON-NAVIGATION POSITION/VELOCITY/TIME (PVT) OUTPUT****1 Applicability**

This ETSO provides the requirements which circuit card assembly (CCA) functional sensors using aircraft-based augmentation for navigation and non-navigation position/velocity/time (PVT) output, that are designed and manufactured on or after the date of this ETSO, must meet in order to be identified with the applicable ETSO marking.

ETSO-2C206 is intended as a means for manufacturers of end-use equipment that incorporates a GNSS CCA to rationalise their ETSO-C196b application for a GNSS PVT sensor by using an ETSO-authorised GNSS CCA for partial certification credit.

An ETSO-2C206 article has a limitation that requires the end-use equipment manufacturer to repeat selected detailed functional tests in the end-use equipment and complete the environmental qualification tests in RTCA document DO-316, Minimum Operational Performance Standards for Global Positioning System/Aircraft-Based Augmentation System Airborne Equipment, dated 14 April 2009 (see paragraphs 3.1.2.2 and 3.2.2 below).

This ETSO standard applies to equipment that is intended to provide PVT information for a navigation management unit application that outputs deviation commands keyed to a desired flight path, or a non-navigation application (such as automatic dependent surveillance — broadcast (ADS-B)). In navigation applications, pilots or autopilots will use the deviations output by the navigation management unit to guide the aircraft. In non-navigation applications, the PVT outputs will provide the necessary capability for the end-use equipment.

2 Procedures**2.1 General**

The applicable procedures are detailed in CS-ETSO, Subpart A.

2.2 Specific

None.

3 Technical Conditions**3.1 Basic****3.1.1 Minimum Performance Standard**

The applicable standards are those provided for functional sensors in RTCA document DO-316, Minimum Operational Performance Standards for Global Positioning System/Aircraft-Based Augmentation System Airborne Equipment, dated 14 April 2009, Section 2.

3.1.2 Environmental Testing and Test Procedures**3.1.2.1 Environmental Testing**

For the applicable environmental standards, see CS-ETSO, Subpart A, paragraph 2.1.

Nevertheless, not all types of environmental test are required for this ETSO standard, as the ETSO article for this ETSO standard is a CCA that will be later integrated into an item of ETSO equipment. Therefore, a minimal set of the environmental test conditions of EUROCAE ED-14/RTCA document DO-160 has been defined (refer to Table 1) in order to verify the performance of the ETSOA article under this minimal set of conditions. The required performance under a particular environmental test is defined in the related test section in RTCA document DO-316, Minimum Operational Performance Standards for Global Positioning System/Aircraft Based Augmentation System Airborne Equipment, dated 14 April 2009, Section 2.2.

This minimal set is defined in Table 1 below. The chosen test category, associated with the selectable parameters in the test conditions per EUROCAE ED-14/RTCA document DO-160 should be documented in the installation manual as limitations for the installation.

The test sections that are identified as optional are not required for an ETSO-2C206 application. Nevertheless, the ETSO CCA article can be subjected to these test conditions by the applicant on a voluntary basis. When optional sections are not tested, they shall be marked with 'X' in the environmental testing summary.

Table 1 — Environmental Qualification Testing minimum set for ETSO-2C206

Environmental Test	EUROCAE ED-14/RTCA DO-160 Section	Requirement for ETSO-2C206
Temperature	4.5	<p>Mandatory</p> <p>If the performance of the module under environmental conditions is dependent on the end-user equipment, it is the responsibility of the applicant to adapt the EUROCAE ED-14/RTCA DO-160 high and low temperature values and temperature variation cycles to the intended installation context.</p> <p>For example, in the case of temperature testing (Section 4.0 of EUROCAE ED-14/RTCA DO-160), the temperature of the environment of the CCA (inside an item of equipment) may be much higher or lower than the equipment level condition expressed in the aforementioned Section 4.0. Therefore, the applicant may qualify their CCA functional sensor based on a chosen intended environment, and, finally, indicate in the installation manual the temperature range for which the correct operation of the CCA is guaranteed.</p>

Environmental Test	EUROCAE ED-14/RTCA DO-160 Section	Requirement for ETSO-2C206
		The dissipation constraints required for the CCA and documented in the installation manual should be considered when establishing the temperature test set-up.
Altitude	4.6	Mandatory
Temperature Variation	5.0	<p>Mandatory</p> <p>As for Section 4.5, if the performance of the CCA under environmental conditions is dependent on the end-user equipment, it is the responsibility of the applicant to adapt the EUROCAE ED-14/RTCA DO-160 high and low temperature values and temperature variation cycles to the intended CCA installation context.</p> <p>As for Section 4.5, for example, in the case of temperature testing (Section 4.0 of EUROCAE ED-14/RTCA DO-160), where the temperature of the environment of the CCA (inside an item of equipment) may be much higher or lower than the equipment level condition as expressed in Section 4.0 of EUROCAE ED-14/RTCA DO-160, the applicant can qualify their CCA based on a chosen intended environment, and, finally, indicate in the installation manual the temperature range for which the correct operation of the CCA functional sensor is guaranteed.</p>
Humidity	6.0	Mandatory
Shock (operational)	7.2	Optional
Shock (Crash Safety)	7.3	Optional
Vibration	8.0	<p>Optional</p> <p>Note: The CCA <u>technology</u> should be assessed for further vibration qualification (ED-14/DO-160). This preliminary assessment could consider the technology diversity of the components of the CCA, as well as the integration density and number of layers of the circuit card. The assessment could be confirmed by tests conducted on a circuit card that is representative of the CCA <u>technology</u> used in the article under certification. This preliminary assessment of the CCA technology under vibration conditions does not constitute credit for the qualification testing of the CCA when it is integrated into the end-user equipment.</p>

Environmental Test	EUROCAE ED-14/RTCA DO-160 Section	Requirement for ETSO-2C206
Explosion Atmosphere	9.0	Optional
Waterproof	10.0	Optional
Fluids Susceptibility	11.0	Optional
Sand and Dust	12.0	Optional
Fungus Resistance	13.0	Optional
Salt Fog	14.0	Optional
Magnetic Effect	15.0	Optional
Power Input	16.0	Mandatory for CCA interfaces that are directly connected to the aircraft power distribution system.
Voltage Spike	17.0	<p>Mandatory for CCA interfaces that are directly connected to the aircraft power distribution system.</p> <p>Note: CCA interfaces that are not directly connected to the aircraft power distribution system will be tested after the integration phase as part of the end-user ETSO application or as part of a type-certification programme.</p>
Audio Frequency Conducted Susceptibility — Power Input	18.0	<p>Mandatory for CCA interfaces that are directly connected to the aircraft power distribution system.</p> <p>Note: CCA interfaces that are not directly connected to the aircraft power distribution system will be tested after the integration phase as part of the end-user ETSO application or as part of a type-certification programme.</p>
Induced-Signal Susceptibility	19.0	<p>Mandatory for CCA interfaces that are directly connected to the aircraft wiring.</p> <p>Note: CCA interfaces that are not directly connected to the aircraft wiring will be tested after the integration phase as part of the end-user ETSO application or as part of a type-certification programme.</p>
Radio Frequency Susceptibility (radiated and conducted)	20.0	<p>Mandatory for the conducted susceptibility of CCA interfaces that are directly connected to the aircraft wiring.</p> <p>Note: CCA interfaces that are not directly connected to the aircraft wiring will be tested after the integration phase as</p>

Environmental Test	EUROCAE ED-14/RTCA DO-160 Section	Requirement for ETSO-2C206
		part of the end-user ETSO application or as part of a type-certification programme.
Emission of Radio Frequency Energy	21.0	Mandatory for the conducted emission of CCA interfaces that are directly connected to the aircraft wiring. Note: CCA interfaces that are not directly connected to the aircraft wiring will be tested after the integration phase as part of the end-user ETSO application or as part of a type-certification programme.
Lightning-Induced Transient Susceptibility	22.0	Mandatory for CCA interfaces that are directly connected to the aircraft wiring. Note: CCA interfaces that are not directly connected to the aircraft wiring will be tested after the integration phase as part of the end-user ETSO application or as part of a type-certification programme.
Lightning Direct Effects	23.0	Optional
Icing	24.0	Optional
Electrostatic Discharge (ESD)	25.0	Optional
Fire, Flammability	26.0	Mandatory for flammability (ED-14/DO-160 Section 26, Category C).

3.1.2.2 Environmental Test Procedures for End User

The end user of this ETSO article will be required to complete the environmental qualification testing after integration of the ETSO-2C206 CCA. In order to allow the end user to properly test the functionality of the CCA functional sensor in environmental conditions, the applicant for a ‘CCA functional sensor’ shall provide the detailed functional test procedures to evaluate the required performance of the CCA functional sensor in compliance with RTCA document DO-316, Minimum Operational Performance Standards for Global Positioning System/Aircraft Based Augmentation System Airborne Equipment, dated 14 April 2009, Section 2.2.

3.1.3 Software

See CS-ETSO, Subpart A, paragraph 2.2.

3.1.4 Airborne Electronic Hardware

See CS-ETSO, Subpart A, paragraph 2.3.

3.2 — Specific

3.2.1 Failure Condition Classification

See CS-ETSO, Subpart A, paragraph 2.4.

A failure of the function defined in paragraph 3.1.1 of this ETSO is a:

- major failure condition for a malfunction of oceanic/remote, en route, terminal navigation and lateral navigation (LNAV) approaches;
- minor failure condition for a loss of navigation in oceanic/remote, en route, terminal navigation and lateral navigation (LNAV) approaches.

3.2.2 Additional Specific

Barometric-aiding fault detection and exclusion (FDE)

If the CCA functional sensor uses barometric-aiding to enhance the availability of FDE, then the equipment shall meet the requirements in RTCA document DO-316, Appendix G.

The applicant shall provide to the end user the detailed functional test procedures of the CCA functional sensor for the end user to complete the environmental testing.

The intended installation environment and the associated installation constraints should be documented in the installation manual.

Limitations

The following specific limitations shall be documented in the installation manual and in the declaration of design and performance (DDP) of the CCA functional sensor:

- ‘The manufacturer of the end-use equipment, using the <insert equipment model> CCA functional sensor, is required to perform the testing described in ETSO-C196<latest revision> Appendix 1 with the CCA functional sensor installed in the end-use equipment.’
- ‘The manufacturer of end-use equipment is required to complete full environmental qualification at the end-use equipment level.’

4 Marking

4.1 General

See CS-ETSO, Subpart A, paragraph 1.2.

4.2 Specific

None.

5 Availability of Referenced Documents

See CS-ETSO, Subpart A, paragraph 3.

[Amdt ETSO/16]

ETSO-2C515 A1

ED Decision 2020/011/R (applicable from 25.7.2020)

AIRCRAFT HALOCARBON CLEAN AGENT HANDHELD FIRE EXTINGUISHER

1 Applicability

This ETSO provides the requirements which an aircraft halocarbon clean agent handheld fire extinguisher that is designed and manufactured on or after the date of this ETSO must meet in order to be identified with the applicable ETSO marking.

2 Procedures

2.1 General

The applicable procedures are detailed in CS-ETSO, [Subpart A](#).

2.2 Specific

None.

3 Technical Conditions

3.1 Basic

3.1.1 Minimum Performance Standard

The applicable standards are those provided in SAE International's Aerospace Standard AS6271, Halocarbon Clean Agent Hand-Held Fire Extinguisher, issued in January 2013, as amended by [Appendices 1 and 2](#) to this ETSO.

3.1.2 Environmental Standard

Refer to the environmental qualification requirements specified in ANSI/UL 2129.

3.1.3 Software

None.

3.1.4 Airborne Electronic Hardware

None.

3.2 Specific

3.2.1 Failure Condition Classification

A failure of the function defined in paragraph 3.1.1 of this ETSO has been determined to be a minor failure condition.

4 Marking

4.1 General

See CS-ETSO, [Subpart A](#), paragraph 1.2.

4.2 Specific

The fire extinguisher type, as specified in paragraph 3.1 of AS6271, shall be marked on the article.

In addition, the fire extinguisher rating, as specified in ANSI/UL 711, shall be marked on the article.

5 Availability of Referenced Documents

See CS-ETSO, [Subpart A](#), paragraph 3.

[Amdt ETSO/11]

[Amdt ETSO/16]

Appendix 1 to ETSO-2C515 A1 – Halocarbon Clean Agent Handheld Fire Extinguisher

ED Decision 2020/011/R

This Appendix prescribes the minimum performance standards (MPS) for aircraft handheld fire extinguishers. The applicable standard is SAE AS6271 ‘Halocarbon Clean Agent Hand-Held Fire Extinguisher’, issued in January 2013. EASA has revised it as follows:

1. On page 4, replace paragraph 3.2 with the following:
‘Halocarbon clean agents shall be registered according to REACH¹ for use in a fire extinguisher to be sold in the European Union (EU). REACH is the EU Regulation on chemicals and their safe use. REACH applies to substances manufactured or imported into the EU in quantities of 1 ton or more per year (see 2.1.7).’
2. On page 5, replace paragraph 4.1.1 with the following:
‘The fire extinguisher/mounting bracket assembly shall be shown to withstand without failure the highest ultimate inertia force/load, applied to all on-axis (X, Y, Z) orientations, specified in the Certification Specifications (CS) applicable to the specific aircraft type or types on which the fire extinguisher is suitable to be installed. The ultimate inertia forces/loads shall be increased, if necessary, to meet the aircraft manufacturer’s specifications for flight and ground loads accordingly. A fitting factor of 1.33 as specified in C2X.561 shall be included to address wear and tear through frequent removal of the fire extinguisher from its mounting bracket. In addition, the manufacturer shall provide an Interface Control Drawing (ICD) specifying for the fire extinguisher/mounting bracket assembly:
 - the ultimate inertia force/loads shown during qualification,
 - the mounting orientations (X, Y, Z) for installation,
 - the interface loads and the specified means of attachment for installation,
 - the Certification Specification(s) (e.g. CS 25.561) including the amendment for which the assembly is demonstrated to be compliant.’
3. On page 5, add a note to paragraph 5.2.2:
‘Note: If the proposed agent was already proven to pass the seat/toxicity test of the MPS in combination with another fire extinguisher, that test would not need to be repeated for the proposed fire extinguisher/agent combination.’

[Amdt ETSO/16]

¹ Regulation (EC) No 1907/2006 of the European Parliament and of the Council of 18 December 2006 concerning the Registration, Evaluation, Authorisation and Restriction of Chemicals (REACH), establishing a European Chemicals Agency, amending Directive 1999/45/EC and repealing Council Regulation (EEC) No 793/93 and Commission Regulation (EC) No 1488/94 as well as Council Directive 76/769/EEC and Commission Directives 91/155/EEC, 93/67/EEC, 93/105/EC and 2000/21/EC (OJ L 396, 30.12.2006, p. 1).

Appendix 2 to ETSO-2C515 A1 – Halocarbon Clean Agent Handheld Fire Extinguisher

ED Decision 2020/011/R

This Appendix prescribes the minimum performance standards (MPS) for aircraft handheld fire extinguishers. As referred to in SAE AS6271, the applicable standard is ANSI/UL 2129 'Halocarbon Clean Agent Hand-Held Fire Extinguisher', issued in February 2005. EASA has revised it as follows:

1. On page 9, replace paragraph 6.8 with the following:
'An extinguisher shall operate as intended at temperatures from -40°C to 49°C as required per UL2129. Ground survival temperature of the unit shall be -54°C up to 85°C (refer to EUROCAE ED-14/RTCA document DO-160 revisions defined in CS-ETSO, [Subpart A](#), paragraph 2.1, ground survival temperature).'
2. On page 12, replace the first phrase of paragraph 12.4 with the following:
'The maximum indicated gauge pressure shall be between 150 and 250 % of the indicated charging pressure specified by the manufacturer (at either 20° or 21°C).'
3. On page 12, replace paragraph 12.5 with the following:
'The mark used to indicate the charging pressure at the charging temperature (at either 20°C or at 21°C) as specified by the manufacturer shall be a minimum of 0.6-mm wide and not more than 1.0-mm wide.'
4. On page 12, disregard paragraphs 12.6 and 12.7.

[Amdt ETSO/16]

ETSO-2C517

ED Decision 2020/011/R (applicable from 25.7.2020)

AUTOMATIC DEPLOYABLE FLIGHT RECORDER (ADFR) SYSTEMS FOR LARGE AEROPLANES**1 Applicability**

This ETSO provides the requirements which automatic deployable flight recorder (AFDR) systems intended for installation in large aeroplanes that are designed and manufactured on or after the date of this ETSO must meet in order to be identified with the applicable ETSO marking.

2 Procedures

2.1 General

The applicable procedures are detailed in CS-ETSO, Subpart A.

2.2 Specific

None.

3 Technical Conditions

3.1 Basic

3.1.1 Minimum Performance Standard

The applicable standards are those provided in EUROCAE ED-112A, MOPS for Crash Protected Airborne Recorder Systems, dated September 2013, Section 3, as amended by Appendix 1 to this ETSO.

The ADFR system shall also be approved in accordance with the latest revision of the ETSO that is applicable to the supported function:

ETSO-(2)C123()	Cockpit Voice Recorder Systems
ETSO-(2)C124()	Flight Data Recorder Systems
ETSO-(2)C176()	Aircraft Cockpit Image Recorder Systems
ETSO-(2)C177()	Data Link Recorder Equipment

The emergency locator transmitter fitted to the ADFR shall be approved as a minimum in accordance with ETSO-C126c, Type ELT(AD) Class 0 or 1, with capabilities C (Crash resistance), H1 (121.5MHz homing) and be of any generation (capability T.001 or T.018).

3.1.2 Environmental Standard

See CS-ETSO, Subpart A, paragraph 2.1, and EUROCAE ED-112A as amended by Appendix 1 to this ETSO.

3.1.3 Software

See CS-ETSO, Subpart A, paragraph 2.2.

3.1.4 Airborne Electronic Hardware

See CS-ETSO, Subpart A, paragraph 2.3.

3.2 Specific

3.2.1 Failure Condition Classification

See CS-ETSO, Subpart A, paragraph 2.4.

A failure of the ADFR to deploy when required is classified as a minor failure condition.

An unintended deployment of the ADFR is classified as not less than a major failure condition.

Note: The classification of the unintended deployment of the ADFR is driven by the risk to the people on the ground. The unintended deployment of the ADFR may also damage the aircraft. Assessing this impact when installing the article on an aircraft may result in a more stringent classification.

4 Marking

4.1 General

See CS-ETSO, Subpart A, paragraph 1.2.

4.2 Specific

4.2.1 Lettering identification

The equipment shall comply with the identification requirement in EUROCAE ED-112A, Section 3-1, paragraph 3-1.8.3 as amended by Appendix 1 to this ETSO.

5 Availability of Referenced Documents

See CS-ETSO, Subpart A, paragraph 3.

[Amdt ETSO/16]

Appendix 1 to ETSO-2C517 – Minimum Operational Performance Standard (MOPS) for Automatic Deployable Flight Recorder (ADFR) Systems

ED Decision 2020/011/R

The applicable standard is EUROCAE ED-112A, MOPS for Crash Protected Airborne Recorder Systems, dated September 2013, and shall be modified as per Table 1 below.

Table 1 — Modification of EUROCAE ED-112A for ADFR systems

Location	Initial ED-112A text	Amending text
3-1.1	<p>This section details the additional requirements and exceptions that are specific to deployable recorders. The requirements specified in this section shall be met in addition to the requirements of Sections 1 and 2, together with Sections 4 and 5 as applicable, and the appropriate recorder specific parts.</p> <p>A deployable recorder is a recording medium housed in a crash-protected memory module that is automatically deployed (released) from the aircraft at the start of an accident sequence. Its characteristics have the objective of enabling it to land at low speeds clear of the main aircraft wreckage, or, in the event of an over-water accident, its flotation characteristics enable it to float on water. Since the recorder is no longer with the aircraft it should be equipped with a means to locate it.</p> <p>This type of recorder is attached to the exterior of the airframe, and under normal conditions, functions in the same manner as a fixed recorder. The Recorder Memory Unit, Beacon Transmitters, Antennas, Battery Pack and the survival packaging for these units are all an integral part of the Automatic Deployable Package.</p> <p>The deployable Package incorporates flight characteristics that enable it to deploy and rapidly establish a flight trajectory that clears the airframe.</p>	<p>This section details the additional requirements and exceptions that are specific to deployable recorders. The requirements specified in this section shall be met in addition to the requirements of Sections 1 and 2, together with the requirements of Sections 4 and 5 as applicable, and the appropriate recorder-specific parts.</p> <p>A deployable recorder is a recording medium housed in a crash-protected memory module that is automatically deployed (released) from the aircraft at the start of an accident sequence. Its characteristics have the objective of enabling it to land at low speeds clear of the main aircraft wreckage or, in the event of an over-water accident, its flotation characteristics enable it to float on water. An ELT is embedded in the deployable recorder to permit determination of the location of the point of the end of flight, and to locate the recorder.</p> <p>This type of recorder is attached to the exterior of the airframe, and under normal conditions, it functions in the same manner as a fixed recorder. The recorder memory unit, beacon transmitters, antennas, battery pack and the survival packaging for these units are all integral parts of the automatic deployable package.</p> <p>The deployable package incorporates flight characteristics that enable it to deploy and rapidly establish a flight trajectory that clears the airframe.</p>

Location	Initial ED-112A text	Amending text
3-1.2		Ignore 3-1.2
3-1.3	This section defines the minimum specification to be met for Deployable Recorder Systems. It is applicable to any crash-protected recorder that is designed to be deployed, its ancillary equipment and its installation in civil aircraft.	This section defines the minimum specifications to be met for automatic deployable flight recorder systems. It is applicable to any crash-protected recorder that is designed to be deployed from a large aeroplane, and to its ancillary equipment.
3-1.4	<p>3-1.4 APPLICATION</p> <p>Compliance with this section will ensure that deployable systems will perform their function under the conditions encountered in aircraft operations.</p>	<p>Replace by the following paragraph:</p> <p>3-1.4 DEFINITIONS</p> <p>The following definitions are provided for the terms that are used in Section 3.</p> <p>Activation depth The nominal depth of the hydrostatic sensor at which it triggers the deployment of the automatic deployable package (3-1.7.2, 3-3.2.10 as defined in this appendix).</p> <p>ADFR Automatic deployable flight recorder</p> <p>ADFR system The system composed of:</p> <ul style="list-style-type: none"> — the automatic deployable package; and — the system components installed in the aircraft and that support the deployment (the deployment mechanism, sensors except those that detect the deformation of the aircraft, etc.) and the recording. <p>Automatic deployable package The part of the system that is deployed, including the crash-protected memory module, the ELT (also named radio location beacon in ED-112A), its antenna and battery, contained in a floatable aerofoil.</p> <p>Deployment case A deployment condition as defined in Appendix 2 to this ETSO.</p> <p>Deployment time The time from a positive indication of a crash until the deployable recorder is released (ED-112A 3-1.7 f.).</p> <p>Immersion depth The maximum depth of immersion in salt water at which the automatic deployable</p>

Location	Initial ED-112A text	Amending text
		<p>package has been tested (3-3.2.8).</p> <p>Release point The point of the aircraft fuselage from which the automatic deployable package is released.</p> <p>Tested impact speed The speed used in the impact shock test in Section 3-3.2.1 as amended by this appendix, which is declared by the equipment manufacturer.</p>
3-1.5.1	<p>In addition to the safety requirements specified in paragraph 2-1.3.1, the following requirements shall apply to all deployable recorders:</p> <p>a. The exterior of the equipment shall have no sharp edges or projections that could damage inflatable survivable equipment or injure persons.</p> <p>b. The overall quantitative probability (per flight hour) of the failure event ‘non-commanded deployment’ shall be $< 10^{-7}$. This probability objective addresses such hardware and software components, which contribute directly to the deployment event.</p>	<p>In addition to the safety requirements specified in Section 2-1.3.1, the exterior of the automatic deployable package shall have no sharp edges or projections that could damage inflatable survivable equipment or injure persons.</p>
3-1.5.2	<p>In addition to the certification documents specified in paragraph 2-1.3.4, the following shall be provided:</p> <p>a. Instructions shall be provided for safely removing deployable recorders from the aircraft for maintenance purposes.</p> <p>b. The transmission frequency and modulation characteristics of the radio location beacon.</p>	<p>In addition to the certification documents specified in Section 2-1.3.4, the following shall be provided:</p> <p>a. The transmission frequency and modulation characteristics of the radio beacon.</p> <p>b. Installation instructions that contain:</p> <ol style="list-style-type: none"> 1. the tested impact speed (Impact shock test in Section 3-3.2.1); 2. the deployment time as defined in 3-1.7.f; 3. the distances required for the automatic deployable package to reduce its speed to the tested impact speed in the deployment cases as defined in Appendix 2 to this ETSO;

Location	Initial ED-112A text	Amending text
		<ol style="list-style-type: none"> 4. the activation depth at which the hydrostatic sensor triggers the deployment (3-1.7.2); 5. the immersion depth that the automatic deployable package can withstand as tested in 3-3.2.8; 6. other installation constraints ensuring that the automatic deployable package is released before the immersion can disable the system; 7. the maximum ice thickness that can be permitted before de-icing action is necessary, as determined during the icing test in Table 2 of this ETSO; 8. the recommended recorder orientation on the fuselage to ensure the performance of the deployment when installed; 9. instructions for safely removing deployable recorders from the aircraft for maintenance purposes; 10. the kinetic energy of the automatic deployable package once deployed from a fixed position; 11. other installation constraints. <p>The ADFR system installation manual shall state that the installer must verify that:</p> <ol style="list-style-type: none"> a. the automatic deployable package is installed so that it may not be crushed or penetrated by aircraft parts when deployed and is located in an area limiting the exposure to fire before and after an accident; b. the hydrostatic sensor is installed in a fuselage section as close as possible as the one of the release mechanism; c. the installation is likely to result in an impact speed of the automatic deployable package that is less than the tested impact speed selected for the impact shock test of the crash-protected recording medium (Section 3-3.2.1) for the deployment

Location	Initial ED-112A text	Amending text
		<p>cases listed in Appendix 2 to this ETSO – this may be achieved by comparing the distances determined in 3-1.5.2 b. 3. to the distances between the release point and the aircraft nose for case 1 and between the release point and the lowest part of the fuselage for case 2;</p> <p>d. the installation minimises the risk that the deployment of the automatic deployable package in normal flight conditions affects the capability of continued safe flight and landing.</p>
3-1.6	Refer to ED-112A	Unchanged
3-1.6.1	<p>A visual method to alert the cockpit crew when the deployable recorder is no longer captive to the aircraft shall be provided.</p> <p>The cockpit crew shall have an unobstructed view of the visual indicator when in the normal seated position.</p> <p>The brilliance of any indicator may be adjustable to levels suitable for data interpretation under all cockpit ambient light conditions ranging from total darkness to reflected sunlight.</p>	The ADFR system shall provide a means to inform the flight crew that the recorder is no longer captive to the aircraft.
3-1.7.a	Refer to ED-112A	Unchanged
3-1.7.b	Refer to ED-112A	Unchanged
3-1.7.c	Refer to ED-112A	Unchanged
3-1.7.d.	Refer to ED-112A	Ignore 3.1.7.d.
3-1.7.e.	Refer to ED-112A	Ignore 3.1.7.e.
3-1.7.f	Refer to ED-112A	Unchanged
3-1.7.g	Refer to ED-112A	Unchanged
3-1.7.h		h. There shall be no means for manual deployment.
3-1.7.i		i. when deployed on the ground from a static position, the point of impact of the automatic deployable package shall be within 20 metres of the deployment mechanism in any direction over a horizontal plane one metre below the release point.

Location	Initial ED-112A text	Amending text
3-1.7.	<p>The design characteristics of a deployable recorder should result in the recorder landing clear of the aircraft wreckage.</p> <p>The unit shall incorporate flight characteristics that enable it to rapidly establish a flight trajectory that clears the airframe.</p> <p>The unit shall not be given sufficient initial momentum on deployment such that its release could endanger ground support personnel or the aircraft itself.</p>	<p>The design characteristics of a deployable recorder should result in the recorder landing clear of the aircraft wreckage.</p> <p>The automatic deployable package shall incorporate flight characteristics that enable it to rapidly establish a flight trajectory that clears the airframe.</p> <p>When the aircraft stands on the ground, the automatic deployable package shall not be given sufficient initial momentum on deployment such that its release could endanger ground support personnel or the aircraft itself.</p> <p>The automatic deployable package shall be shown to satisfy the deceleration requirements detailed in Appendix 2 to this ETSO.</p>
3-1.7.1	Refer to ED-112A	Ignore 3-1.7.1
3-1.7.2	Sensor(s) shall be installed to activate deployment of the recorder at a depth of 3 m or more.	<p>The ADFR system shall deploy the automatic deployable package when it detects an immersion by measuring the water pressure. A pressure equivalent to a water activation depth between 1.5 and 2.5 m is recommended for the switching threshold of a hydrostatic pressure switch.</p> <p>The system design shall be such that its progressive immersion does not affect the deployment of the automatic deployable package if installed as per the installation constraints.</p> <p>Automatic deployment shall take place up to 15 minutes after the loss of external electrical power.</p> <p>The installation manual shall contain the identification of all the component electronics, power sources, mechanisms and interconnecting cables, as well as any caution notes that are needed to ensure the activation and deployment of the ADFR system.</p>
3-1.8.1	Refer to ED-112A	Unchanged

Location	Initial ED-112A text	Amending text
3-1.8.2	<p>All deployable recorders shall be equipped with a Class 1 dual frequency 406 MHz and 121.5 MHz radio location beacon compliant with the requirements of ED-62A instead of the underwater locator beacon and its attachment as specified in paragraph 2-1.16.4.</p> <p>The radio locating device shall be attached to the deployable recorder such that the aerodynamic properties of the recorder are not adversely affected and the risk of damage to, or separation of, the locating device is minimised.</p> <p>In addition to meeting the endurance requirements specified by ED-62A, the 121.5MHz radio shall operate for an additional 102 hours for a total minimum operational duration of 150 hours. For the operational duration in exceedance of ED-62A (between 48 hours and 150 hours of operation), the minimum Equivalent Isotropic Radiated Power (EIRP) for the 121.5MHz radio shall be 5mW.</p> <p><i>NOTE: Other required characteristics of the radio location beacon are outside the scope of this MOPS. Reference should be made to the applicable equipment standard.</i></p>	<p>The automatic deployable package shall be equipped with an ELT that is approved in accordance with ETSO-C126c, type ELT(AD) Class 0 or 1 with capabilities C (crash resistance), H1 (121.5 MHz homing) and be of any generation (capability T.001 or T.018) instead of the underwater locator beacon and its attachment as specified in Section 2-1.16.4.</p> <p>The ELT shall radiate nominal power levels (as required per ETSO-C126c) for any orientation of the deployable package that is stable when laid on a flat horizontal surface.</p> <p>The radio locating device shall be attached to the deployable recorder such that the aerodynamic properties of the recorder are not adversely affected and the risk of damage to, or separation of, the locating device is minimised.</p> <p>In addition to meeting the endurance requirements specified by ED-62A, the 121.5MHz radio shall operate for an additional 102 hours for a total minimum operational duration of 150 hours. For the operational duration in exceedance of ED-62A (between 48 hours and 150 hours of operation), the minimum Equivalent Isotropic Radiated Power (EIRP) for the 121.5MHz radio shall be 5 mW.</p>
3-1.8.3	Refer to ED-112A	<p>Add the following text:</p> <p>If the automatic deployable package (ADP) is designed to be installed with one side exposed to the exterior of the aircraft and if its kinetic energy can reach 44 Joules within 0.5 metre from the release point when the aircraft is standing on the ground, that side of the ADP shall bear a conspicuous label.</p> <p>Note: This label is intended to provide a visual warning to maintenance and servicing crews, as well as to rescue or other personnel at the scene of an accident or incident in the event that the ADFR has not deployed.</p>
3-1.8.4	Refer to ED-112A	Unchanged

Location	Initial ED-112A text	Amending text
3-2.1	<p>CHAPTER 2-3 defines the environmental tests to be performed on the recorder system.</p> <p>Deployable recorders shall satisfy the functional requirements as detailed in Chapter 4 of the applicable function specific Part(s).</p>	<p>Table 2 of this ETSO defines the minimum environmental tests to be performed on the ADFR system.</p> <p>During each test, an unintended deployment of the ADFR shall be considered to indicate that the test has been failed. Unless Table 2 of this ETSO specifies that the deployment shall be performed during the tests, the successful deployment shall be verified after submission of the equipment to the test (this may be achieved by verifying the successful deployment only once after a group of tests has been performed on a single item of equipment).</p> <p>The ADFR system shall satisfy the functional requirements as detailed in Chapter 4 of the applicable function-specific part(s).</p> <p>The verification of deployment aspects may be performed using a dummy automatic deployable package.</p>
3-3.1	Refer to ED-112A	Unchanged
3-3.2.1	<p>The integrity of the crash-protected recording medium contents and the proper operation of the Radio Location Beacon are to be validated when subjected to the following impact shock test.</p> <p>a. Subject the deployable recorder package, to an impact shock applied to the most probable landing attitude in the most damage vulnerable direction. The shock shall be such a level as to simulate a landing velocity of 46.33 m/s (152 ft/s) onto a hard surface such as rock, concrete or steel.</p> <p>NOTE: The definitions of ‘landing attitude’ and ‘most damage-vulnerable direction’ should not be limited to the three primary axes of the recorder.</p> <p>b. The deployable recorder containing the protected memory module shall impact or be impacted by a hard surface (50 mm thick steel plate of dimensions greater than the overall dimensions of the recorder) at a minimum impact velocity of 46.33 m/s (152 ft/s). Figure 3-3.1</p>	<p>The integrity of the contents of the crash-protected recording medium, the proper operation of the radio beacon and the seaworthiness of the automatic deployable package are to be validated when subjected to the following impact shock test.</p> <p>a. Subject the automatic deployable package to an impact shock that is applied to the most probable impact attitude in the most damage-vulnerable direction. The shock shall be at such a level as to simulate an impact speed of at least 46.33 m/s (152 ft/s) onto a hard surface such as a rock, concrete or steel.</p> <p>The equipment manufacturer may demonstrate a higher impact speed for the crash-protected recording medium (that may be specified by the organisation installing the ADFR) and declare it in the installation manual and the declaration of design and performance (DDP). In this case, the proper operation of the radio beacon and the seaworthiness of the automatic deployable package are still required to be demonstrated for the impact speed of 46.33 m/s.</p>

Location	Initial ED-112A text	Amending text
	<p>illustrates an acceptable impact shock test set-up for deployable recorders. Figure 3-3.2 illustrates an acceptable method and set-up for retrieval of the deployable after impact. The mass of the impact plate shall be greater than 10 times the mass of the deployable recorder and experience no yield when subjected to the impact.</p> <p>c. Apart from the test sequence specified in paragraph 3-1.8 a iii, electronic components external to the crash-protected memory may be removed and replaced with representative mass models prior to commencing the impact shock test. For test sequence iii, the radio location beacon shall be installed and the test carried out on the complete recorder.</p>	<p>NOTE: The definitions of ‘impact attitude’ and ‘most damage-vulnerable direction’ should not be limited to the three primary axes of the recorder.</p> <p>b. The deployable recorder that contains the protected memory module shall impact or be impacted by a hard surface (a 50-mm-thick steel plate of dimensions greater than the overall dimensions of the recorder) at a minimum impact velocity of 46.33 m/s (or higher as declared by the manufacturer). Figure 3-3.1 illustrates an acceptable impact shock test set-up for the automatic deployable package. Figure 3-3.2 illustrates an acceptable method and set-up for the retrieval of the deployable after impact. The mass of the impact plate shall be greater than 10 times the mass of the deployable recorder and shall not yield when it is subjected to the impact.</p> <p>c. Apart from the test sequence specified in paragraph 3-1.8.a.iii, electronic components that are external to the crash-protected memory may be removed and replaced with representative mass models prior to commencing the impact shock test. For test sequence iii, the radio beacon shall be installed and the test carried out on the complete automatic deployable package.</p>
3-3.2.2 (except note)	Refer to ED-112A	Unchanged
3-3.2.2 (note)	<p><i>NOTE: This test methodology is the same as the penetration test specified for Emergency Locator Transmitters (ELTs) in ED-62A.</i></p>	<p><i>NOTE: This test methodology is the same as that for the impact test specified for emergency locator transmitters (ELTs) in ED-62B Section 4.5.10. Per ETSO-C126c, the ELT(AD)s fitted to the ADFR are required to pass the ED-62B impact test described in Section 4.5.10.</i></p>
3-3.2.3	Refer to ED-112A	Add the following note to ED-112A Section 3-3.2.3:

Location	Initial ED-112A text	Amending text
		<i>NOTE: Per ETSO-C126c, the ELT(AD)s fitted to the ADFR are required to pass the static crush test, as described in ED-62B Section 4.5.12.</i>
3-3.2.4	Refer to ED-112A	Add the following note to ED-112A Section 3-3.2.4: <i>NOTE: Per ETSO-C126c, the ELT(AD)s fitted to the ADFR are required to pass the ED-62B Section 4.5.14 fire test.</i>
3-3.2.5	Refer to ED-112A	Add the following note to ED-112A Section 3-3.2.5: <i>NOTE: Per ETSO-C126c, the ELT(AD)s fitted to the ADFR are required to pass the ED-62B Section 4.5.14 fire test.</i>
3-3.2.6	Refer to ED-112A	Unchanged
3-3.2.7	Refer to ED-112A	Unchanged
3-3.2.8	The deployable recorder shall be buoyant and, when floating in fresh water or salt water, shall be self-righting and sufficiently stable to maintain the antenna substantially in its normal operating position and to transmit on its 406 MHz and 121.5 MHz frequencies. Transmission of the ELT frequencies shall be demonstrated by testing in fresh and then salt water and confirming the reception of the 406 MHz Alert frequency via COSPAS SARSAT Satellite, and the 121.5 MHz homing frequency via a SAR Homing receiver. This test shall be performed in water conditions that are representative of an open sea state 7 (equivalent to Beaufort Scale force 10).	<p>The automatic deployable package shall be buoyant and, when floating in fresh water or salt water, shall be self-righting and sufficiently stable to maintain the antenna substantially in its normal operating position, and to transmit on its 406-MHz and 121.5-MHz frequencies.</p> <p>The automatic deployable package shall be immersed at the immersion depth for 5 minutes and shall then return to the surface when released.</p> <p>Transmission on the ELT frequencies shall then be demonstrated by conducting testing in fresh water and confirming the reception of the 406-MHz alert frequency via the COSPAS SARSAT Satellite. The 121.5-MHz homing transmission shall be tested in the conditions described in ED-62B Section 5.5.6.</p>
3-3.2.9 a.	Unless it can be shown that the recording medium can withstand the conditions associated with deep sea immersion and that it is unlikely to be damaged as a consequence of collapse of any protective armour, immerse the recorder in sea water at a pressure of 60 MPa (equivalent to a depth of 6 000 m (20 000 feet) for a period of 30 days.	Ignore 3-3.2.9.a.

Location	Initial ED-112A text	Amending text
3-3.2.9 b.	Unless it can be shown that the recording medium and the identification required by paragraph 2-1.16.3 are resistant to the corrosive effects of sea water, immerse the recorder in sea water at a depth of 3 m and nominal temperature of + 25°C for a period of 30 days.	Unless it can be shown that the recording medium and the identification required by Section 2-1.16.3 are resistant to the corrosive effects of seawater, immerse the recorder in seawater at a depth of 3 m and a nominal temperature of at least + 25.0 °C for a period of 90 days.
3-3.2.10		<p>Add a section: Water immersion initiation test</p> <p>This test may be performed on an additional individual ADFR system that is not part of the test sequences defined in 3-1.8.1.</p> <p>The geometry of test set-up (orientation, relative position of the release mechanism and of the hydrostatic sensor) shall be the least favourable one permitted by the installation constraints with regard to the risk of being disabled by immersion.</p> <p>The ELT shall be activated and the system deprived of external power before the test for the duration defined in Section 3-1.7.2, as amended by this Appendix.</p> <p>Submerge it in fresh water at a speed of not less than 1 m per minute. Verify that the ADFR deploys when the hydrostatic pressure sensor is at a depth of between 1.5 and 2.5 m.</p> <p>Perform an aliveness test of the ELT as defined in EUROCAE ED-62B Section 4.3.1.</p>

Table 2 — Environmental test for ADFR systems

Test	EUROCAE ED-14G/ RTCA DO-160G Section	Minimum category/Remarks
Temperature	4.0	Category to be defined by the manufacturer. Deployment shall be tested at the short-time low and short-time high operating temperatures.
Altitude	4.0	Category to be defined by the manufacturer.
Temperature Variations	5.0	A, S1 or S2

Test	EUROCAE ED-14G/ RTCA DO-160G Section	Minimum category/Remarks
Humidity	6.0	C for the components and parts of the ADFR system that are exposed to the outside air, A for the rest of the system. Deployment shall be tested at the end of exposure period, without draining off any condensed moisture.
Operational Shock	7.0	Category to be defined by the manufacturer.
Crash Safety Shock	7.0	Category to be defined by the manufacturer.
Vibration	8.0	R, U or U2 and H or Z A deployment shall be performed during the test, at the most unfavourable vibration condition (e.g. the resonance frequency).
Explosion Proofness	9.0	As required.
Waterproofness	10.0	S for the components and parts of the ADFR system that are exposed to the outside air, Y for the rest of the system including for the water sensor.
Fluids Susceptibility	11.0	F, with at least fuel, hydraulic fluids, lubricating oils, de-icing fluids and fire extinguishants.
Sand and Dust	12.0	S
Fungus Resistance	13.0	F
Salt Spray	14.0	T
Magnetic Effect	15.0	Category to be defined by the manufacturer.
Power Input	16.0	Category to be defined by the manufacturer. A deployment shall be performed under the most unfavourable testing conditions. The unit under test may encompass only the installed components of the ADFR system.
Voltage Spike	17.0	Category to be defined by the manufacturer. The unit under test may encompass only the installed components of the ADFR system.
AF Conducted Susceptibility	18.0	Category to be defined by the manufacturer. A deployment shall be performed during the test under the most unfavourable testing conditions. The unit under test may encompass only the installed components of the ADFR system.

Test	EUROCAE ED-14G/ RTCA DO-160G Section	Minimum category/Remarks
Induced Signal Susceptibility	19.0	Category to be defined by the manufacturer. A deployment shall be performed during the test under the most unfavourable testing condition. The unit under test may encompass only the installed components of the ADFR system.
RF Susceptibility	20.0	Category to be defined by the manufacturer. A deployment shall be performed during the test under the most unfavourable testing conditions.
RF Emission	21.0	Category to be defined by the manufacturer.
Lightning-Induced Transient Susceptibility	22.0	Category to be defined by the manufacturer.
Lightning Direct Effects	23.0	Category to be defined by the manufacturer. The recorder is required to successfully deploy after a direct impact. No unintended deployment shall occur, and no part shall detach.
Icing	24.0	The test shall be performed for Categories B and C. For Category B, 2 cycles are required. The deployment of the recorder shall be tested at the end of first cycle and at the end of the low-temperature phase for the second cycle. For Category C, the deployment shall be tested after the required ice thickness (as declared by the manufacturer) is met and the temperature is stabilised at its lowest value as required by the ED-14G/DO-160G test.
Electrostatic Discharge	25.0	A
Fire	26.0	C + ED-112A Sections 3-3.2.4 and 3-3.2.5.

[Amdt ETSO/16]

Appendix 2 to ETSO-2C517 – Distances Required for the Deceleration of the Automatic Deployable Package

ED Decision 2020/011/R

This Appendix defines the minimum acceptable performance for the deceleration of the automatic deployable package. The objective is to ensure that the collision of the automatic deployable package with the ground will not damage the crash-protected recording medium in two cases that are typical of an accident trajectory. For those cases, the applicant will perform the following tasks:

1. consider the tested impact speed used in the impact shock test (Section 3-3.2.1) V_{impact} ;
2. determine the distance D_{captive} that is required for the automatic deployable package to be released;
3. determine the distance D_{released} that the automatic deployable package needs to decelerate to the tested impact speed once released; and
4. compare the total distance $D_{\text{Decelerate}}$ (distance needed for the deployable package to be released and decelerated by drag forces so that its speed is less than the tested impact speed) with a maximum value D_{max} defined in Table 3.

Note: The applicant may increase the tested impact speed V_{impact} to reduce $D_{\text{Decelerate}}$.

The initial release position, attitude and speed of the automatic deployable package are determined by the platform attitude and speed vector as defined in Table 3 and Figure 1 below and by the orientation of the ADFR relative to the platform. They shall account for any initial speed increment or accelerations that may be provided by the deployment mechanism.

If the ADFR manufacturer does not limit the installation of the ADFR to only one deployment direction relative to the platform (e.g. deployment in the direction of axis z or direction of y axis), the deployment direction resulting in the highest impact speed shall be considered, or cases shall be added to cover the permitted direction domain.

The impact surface is the plane defined by the following conditions:

- its normal vector \vec{n} is specified in table 3 of this ETSO; and
- the component of the automatic deployable package speed along this normal vector \vec{n} is equal to the speed value V_{impact} used for the impact shock test of the crash-protected recording medium (Section 3-3.2.1).

The distance D_{captive} is the distance covered by the platform from the positive indication of a crash until the deployable package is released (3-1.7 f.).

The distance D_{released} is the distance between the initial release position and the impact surface.

The distance $D_{\text{Decelerate}}$ is equal to $D_{\text{Decelerate}} = D_{\text{captive}} + D_{\text{released}}$.

Deceleration requirements

For each deployment case specified in Table 3 of this ETSO, the distance $D_{\text{Decelerate}}$ shall be less than the maximum distance D_{max} .

Note: This condition is used to determine whether recorded data is likely to be retained by the crash-protected recording medium after a collision with terrain, when the ADFR system is installed on a large aeroplane.

Deployment case	Release platform attitude			Release platform speed vector			Impact surface - Normal vector \vec{n}			Maximum distance to reduce the speed component along the normal vector to the tested impact speed value (D_{max}) m
	Pitch	Roll	Yaw	Vx	Vy	Vz	x	y	z	
	°			m/s						
Case 1	0	0	0	150	0	0	-1	0	0	70
Case 2	15	0	0	0	0	-50	0	0	1	20

Table 3: Deployment cases to be considered

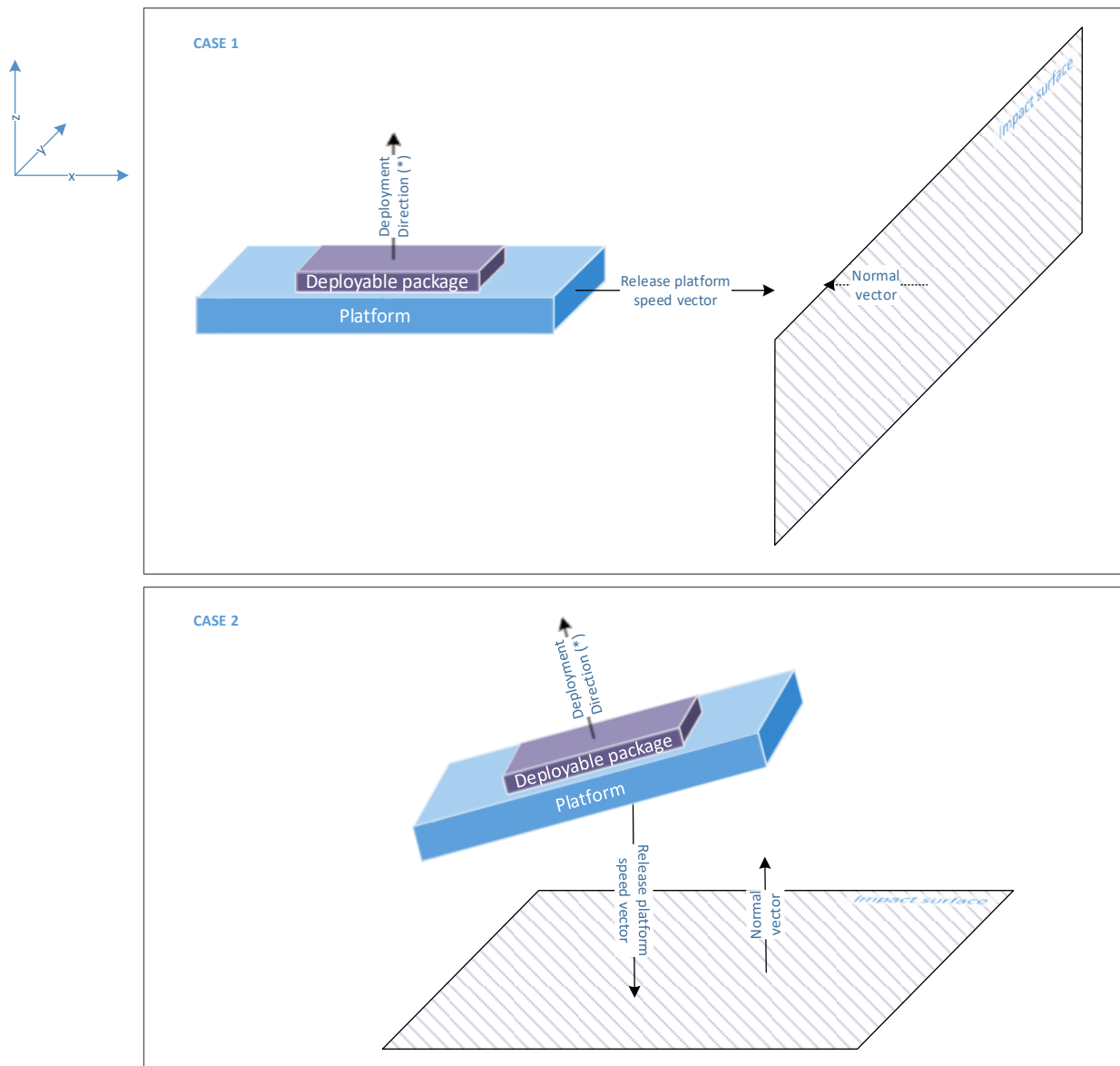

(*) Different deployment directions relative to the platform may have to be considered depending on the installation constraints. The figure above represents a case where the deployable package is deployed upwards when installed in the aircraft.

Figure 1: Deployment cases to be considered

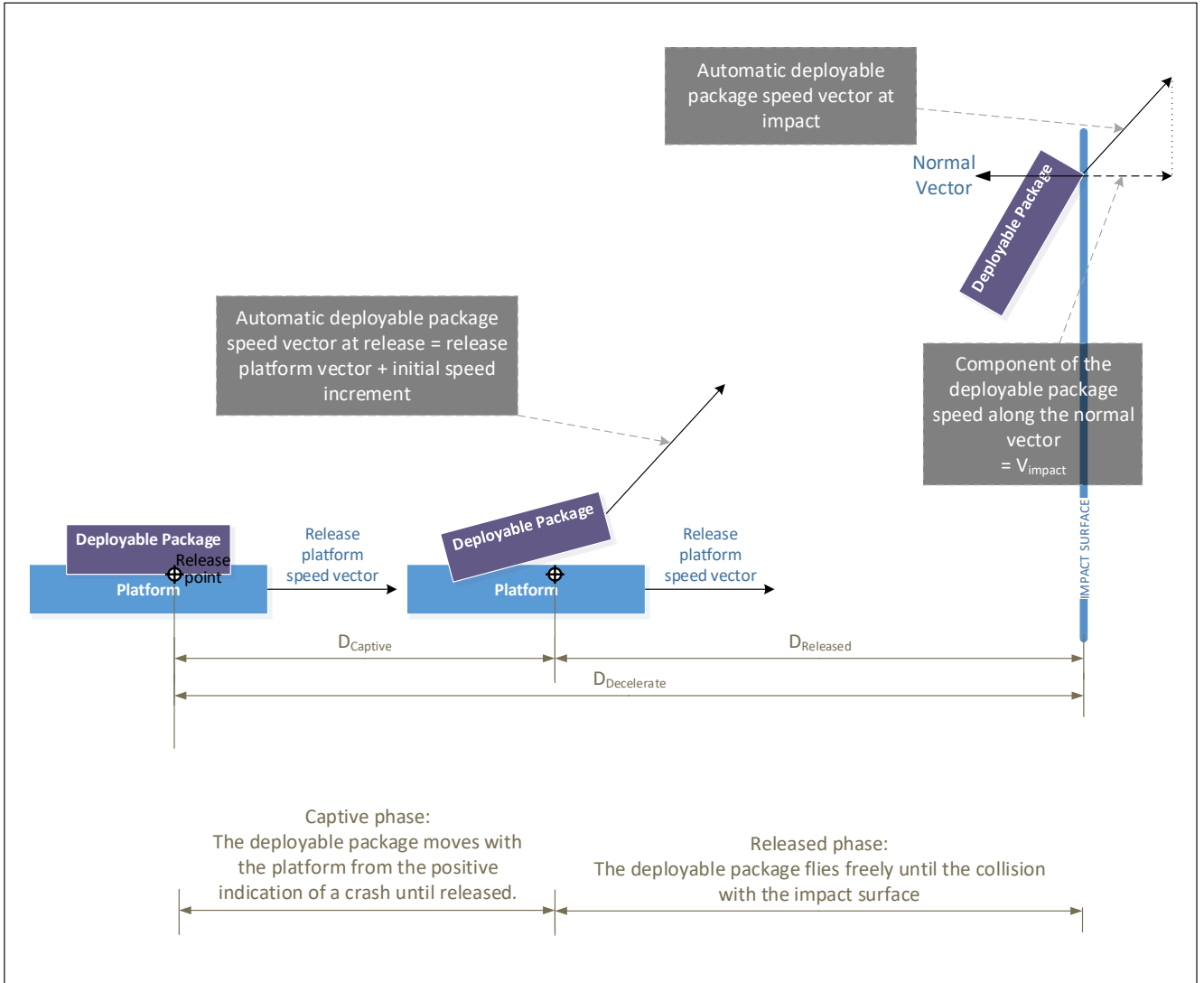

Figure 2: Sequence of the automatic deployable package release

[Amdt ETSO/16]

ETSO-2C518*ED Decision 2020/011/R (applicable from 25.7.2020)***RUNWAY OVERRUN AWARENESS AND ALERTING SYSTEMS****1 Applicability**

This ETSO provides the requirements which runway overrun awareness and alerting systems that are designed and manufactured on or after the date of this ETSO must meet in order to be identified with the applicable ETSO marking.

2 Procedures**2.1 General**

The applicable procedures are detailed in CS-ETSO, Subpart A.

2.2 Specific

None.

3 Technical Conditions**3.1 Basic****3.1.1 Minimum Performance Standard**

The applicable standards are those provided in EUROCAE ED-250, Minimum Operational Performance Standards for a Runway Overrun Awareness and Alerting System, dated December 2017.

3.1.2 Environmental Standard

See CS-ETSO, Subpart A, paragraph 2.1.

3.1.3 Software

See CS-ETSO, Subpart A, paragraph 2.2.

3.1.4 Airborne Electronic Hardware

See CS-ETSO, Subpart A, paragraph 2.3.

3.2 Specific**3.2.1 Failure Condition Classification**

See CS-ETSO, Subpart A, paragraph 2.4.

4 Marking**4.1 General**

See CS-ETSO, Subpart A, paragraph 1.2.

4.2 Specific

None.

5 Availability of Referenced Documents

See CS-ETSO, Subpart A, paragraph 3.

[Amdt ETSO/16]

ETSO-2C519*ED Decision 2020/011/R (applicable from 25.7.2020)***EMERGENCY BREATHING SYSTEMS (EBSs)****1 Applicability**

This ETSO provides the requirements which emergency breathing systems (EBSs) category A, for operations to or from helidecks that are located in hostile sea areas, that are designed and manufactured on or after the date of this ETSO, must meet in order to be identified with the applicable ETSO marking.

EBS category A means EBSs that are capable of being successfully deployed underwater.

2 Procedures

2.1 General

The applicable procedures are detailed in CS-ETSO, Subpart A.

2.2 Specific

None.

3 Technical Conditions

3.1 Basic

3.1.1 Minimum Performance Standard

The applicable standards are those provided in AeroSpace and Defence Industries Association of Europe — Standardization (ASD-STAN) document EN4856:2018, dated December 2018.

3.1.2 Environmental Standard

See CS-ETSO, Subpart A, paragraph 2.1.

3.1.3 Software

None.

3.1.4 Airborne Electronic Hardware

None.

3.2 Specific

3.2.1 Failure Condition Classification

None.

4 Marking

4.1 General

See CS-ETSO, Subpart A, paragraph 1.2.

4.2 Specific

The specific marking requirements are detailed in ASD-STAN document EN4856:2018.

5 Availability of Referenced Documents

See CS-ETSO, Subpart A, paragraph 3.

[Amdt ETSO/16]